

# RUCKUS FastIron Campus Fabric Configuration Guide, 08.0.95

Supporting FastIron Software Release 08.0.95

# Copyright, Trademark and Proprietary Rights Information

© 2020 CommScope, Inc. All rights reserved.

No part of this content may be reproduced in any form or by any means or used to make any derivative work (such as translation, transformation, or adaptation) without written permission from CommScope, Inc. and/or its affiliates ("CommScope"). CommScope reserves the right to revise or change this content from time to time without obligation on the part of CommScope to provide notification of such revision or change.

## Export Restrictions

These products and associated technical data (in print or electronic form) may be subject to export control laws of the United States of America. It is your responsibility to determine the applicable regulations and to comply with them. The following notice is applicable for all products or technology subject to export control:

*These items are controlled by the U.S. Government and authorized for export only to the country of ultimate destination for use by the ultimate consignee or end-user(s) herein identified. They may not be resold, transferred, or otherwise disposed of, to any other country or to any person other than the authorized ultimate consignee or end-user(s), either in their original form or after being incorporated into other items, without first obtaining approval from the U.S. government or as otherwise authorized by U.S. law and regulations.*

## Disclaimer

THIS CONTENT AND ASSOCIATED PRODUCTS OR SERVICES ("MATERIALS"), ARE PROVIDED "AS IS" AND WITHOUT WARRANTIES OF ANY KIND, WHETHER EXPRESS OR IMPLIED. TO THE FULLEST EXTENT PERMISSIBLE PURSUANT TO APPLICABLE LAW, COMMSCOPE DISCLAIMS ALL WARRANTIES, EXPRESS OR IMPLIED, INCLUDING, BUT NOT LIMITED TO, IMPLIED WARRANTIES OF MERCHANTABILITY AND FITNESS FOR A PARTICULAR PURPOSE, TITLE, NON-INFRINGEMENT, FREEDOM FROM COMPUTER VIRUS, AND WARRANTIES ARISING FROM COURSE OF DEALING OR COURSE OF PERFORMANCE. CommScope does not represent or warrant that the functions described or contained in the Materials will be uninterrupted or error-free, that defects will be corrected, or are free of viruses or other harmful components. CommScope does not make any warranties or representations regarding the use of the Materials in terms of their completeness, correctness, accuracy, adequacy, usefulness, timeliness, reliability or otherwise. As a condition of your use of the Materials, you warrant to CommScope that you will not make use thereof for any purpose that is unlawful or prohibited by their associated terms of use.

## Limitation of Liability

IN NO EVENT SHALL COMMSCOPE, COMMSCOPE AFFILIATES, OR THEIR OFFICERS, DIRECTORS, EMPLOYEES, AGENTS, SUPPLIERS, LICENSORS AND THIRD PARTY PARTNERS, BE LIABLE FOR ANY DIRECT, INDIRECT, SPECIAL, PUNITIVE, INCIDENTAL, EXEMPLARY OR CONSEQUENTIAL DAMAGES, OR ANY DAMAGES WHATSOEVER, EVEN IF COMMSCOPE HAS BEEN PREVIOUSLY ADVISED OF THE POSSIBILITY OF SUCH DAMAGES, WHETHER IN AN ACTION UNDER CONTRACT, TORT, OR ANY OTHER THEORY ARISING FROM YOUR ACCESS TO, OR USE OF, THE MATERIALS. Because some jurisdictions do not allow limitations on how long an implied warranty lasts, or the exclusion or limitation of liability for consequential or incidental damages, some of the above limitations may not apply to you.

## Trademarks

ARRIS, the ARRIS logo, COMMSCOPE, RUCKUS, RUCKUS WIRELESS, the Ruckus logo, the Big Dog design, BEAMFLEX, CHANNELFLY, FASTIRON, ICX, SMARTCELL and UNLEASHED are trademarks of CommScope, Inc. and/or its affiliates. Wi-Fi Alliance, Wi-Fi, the Wi-Fi logo, Wi-Fi Certified, the Wi-Fi CERTIFIED logo, Wi-Fi Protected Access, the Wi-Fi Protected Setup logo, Wi-Fi Protected Setup, Wi-Fi Multimedia and WPA2 and WMM are trademarks or registered trademarks of Wi-Fi Alliance. All other trademarks are the property of their respective owners.

# Contents

---

<b>Preface.....</b>	<b>7</b>
Document Conventions.....	7
Notes, Cautions, and Safety Warnings.....	7
Command Syntax Conventions.....	7
Document Feedback.....	8
RUCKUS Product Documentation Resources.....	8
Online Training Resources.....	8
Contacting RUCKUS Customer Services and Support.....	9
What Support Do I Need?.....	9
Open a Case.....	9
Self-Service Resources.....	9
<b>About This Guide.....</b>	<b>11</b>
Supported hardware and software.....	11
What's New in this Document.....	11
<b>Campus Fabric Overview.....</b>	<b>13</b>
Campus Fabric.....	13
FastIron Devices and Campus Fabric Communication.....	15
Campus Fabric Roles and Communication Protocols.....	16
Control and Status Protocol.....	17
Campus Fabric Data Path.....	17
Campus Fabric Terminology.....	19
<b>Planning Considerations for a Campus Fabric Domain.....</b>	<b>23</b>
Campus Fabric Licensing.....	23
Premium Licenses for ICX 7650 or ICX 7850 CB Units.....	23
MACsec Licenses for ICX 7650 or ICX 7850 CB Units.....	23
License Inheritance.....	23
ICX 7150 and ICX 7250 Licenses.....	23
Handling SPX Links with Different Speeds.....	24
Campus Fabric Scalability.....	24
SPX Port Combinations.....	25
Control Bridge Considerations.....	26
Port Extender Considerations.....	27
Campus Fabric Topology Overview.....	28
Rules Governing Campus Fabric Topology.....	29
Supported CB-PE LAG Topologies.....	30
Supported PE Ring Topology.....	32
PE Ring Topology Limitations.....	33
Traffic Flow in a PE Ring Topology.....	33
Best Practices for PE Ring Configuration.....	34
Topologies Not Supported by Campus Fabric.....	35
Topologies Handled by Zero-touch or SPX Interactive-setup.....	38
<b>Campus Fabric Configuration Overview and Interactive Configuration.....</b>	<b>41</b>
Campus Fabric Configuration Overview.....	41
SPX Interactive-setup.....	42

Zero-touch Deployment.....	42
Manual Configuration.....	42
Differences in Campus Fabric Configuration Practices.....	42
Protecting a Unit from Being Discovered.....	44
Zero-touch and SPX Interactive-setup Topology Requirements.....	44
Zero-touch and SPX Interactive-setup for PE Units with Live Traffic.....	45
Invalid Topologies that Can Be Handled by SPX Interactive-setup.....	45
Special Cases Where a Link Can Be Removed to Select All New Units.....	46
SPX LAG Splits and Merges.....	47
Zero-touch and SPX Interactive-setup Deployment Considerations.....	50
Zero-touch and SPX Interactive-setup Deployment Limitation.....	51
Zero-touch and SPX Interactive-setup Deployment Recommendations.....	51
Zero-touch Configuration.....	52
Topologies that Support Zero-touch Configuration.....	52
Additional Zero-touch Considerations.....	53
Using Zero-touch to Add PE Units.....	53
SPX Interactive-setup.....	57
Changing PE IDs with SPX Interactive-setup.....	57
Configuring SPX to Move PE Units without Changing IDs.....	62
Converting a Stack to a PE Chain or Ring.....	64
Converting a PE Chain or Chains to a Ring.....	66
Downloading Images to New Units Before Converting Them to PEs with SPX Interactive-setup or Zero-touch Provisioning.....	67
<b>Campus Fabric Manual Configuration.....</b>	<b>71</b>
Enabling and Configuring the Control Bridge.....	71
Adding a Reserved PE Configuration on the CB.....	72
How PE Units Join a Campus Fabric Domain.....	73
How the CB Applies a Reserved Configuration.....	74
If the PE Unit Has No Reserved Configuration.....	74
If the PE Unit Has a Different Software Image.....	74
Manually Enabling and Configuring PE Units.....	74
SPX Port and LAG Configuration Rules.....	82
Configuration Changes in PE Mode Before Joining the CB.....	83
Regular, Provisional-PE, and PE Mode.....	83
Dynamic Versus Static SPX Configuration.....	87
Campus Fabric Detailed Manual Configuration Example.....	88
CB Configuration.....	88
PE Configuration.....	90
<b>Campus Fabric Considerations for Layer 2, Layer 3, Multicast, Security, and QoS.....</b>	<b>97</b>
Campus Fabric Layer 2 Considerations.....	97
Campus Fabric Layer 3 Unicast Considerations.....	99
Campus Fabric and IP Multicast Considerations.....	100
Multicast E-CID and IEEE 802.1BR.....	100
General Campus Fabric Multicast Considerations.....	100
Considerations for Multicast Forwarding on PE Units.....	101
Campus Fabric Security Considerations.....	101
Security Design Considerations.....	102
Security Performance Considerations.....	102
Additional Security Considerations.....	103
Campus Fabric QoS Considerations.....	103

QoS Classifications for Campus Fabric PE Ports.....	103
QoS Features under Campus Fabric.....	103
QoS for SPX Ports.....	104
Performance Impact.....	104
Control Packets under SPX.....	104
<b>Campus Fabric Management.....</b>	<b>105</b>
Logging in through the Console Port.....	105
Using the Remote CB Console.....	106
PE Console Port Behavior.....	106
Changing the Speed on an SPX Link.....	107
Converting 1-Gbps SPX Links on Downstream PEs to 10-Gbps Links.....	108
Converting Attached PE Candidate Speed by Physically Disconnecting the Units.....	110
Handling Nonoperational PE Units.....	111
Assigning an ID to a PE Unit.....	111
Assigning a PE ID that Has Been Taken.....	112
Replacing a PE Unit.....	112
Converting a Unit to Serve as a Replacement PE.....	113
Replacing PE Units with the Zero-touch or SPX Interactive Utility.....	113
Moving a PE Unit and Retaining Its ID (Manual Methods).....	117
Method 1: Prepare a New Topology by Reconfiguring PE IDs on the CB.....	118
Method 2: Allow Suggested ID or Previous Unit ID Assignment.....	118
Removing a PE Ring and Its Configuration.....	119
Configuring SPX Ports and LAGs on a Live System.....	131
Campus Fabric (SPX) Image Upgrade.....	133
Auto Image Copy Considerations.....	134
Disabling or Re-enabling the Auto Image Copy Process for a Campus Fabric (SPX) Configuration.....	134
Configuring a TFTP Server for Campus Fabric (SPX) auto image copy.....	135
Manual Upgrade of Campus Fabric (SPX) Images Using a Manifest File.....	135
Unconfiguring the CB Stack or PE Units.....	136
Removing SPX Configuration from PE Units.....	136
Removing SPX Configuration from All Units.....	138
Removing Stacking Configuration.....	138
CB Stack Merges and Breaks.....	139
CB Stack Merges.....	139
CB Stack Breaks.....	139
Displaying Campus Fabric (SPX) Information.....	139
SPX Information in show running-config Output.....	139
SPX Information in show configuration Command Output.....	140
Displaying Regular Mode Configuration from a PE Unit.....	140
Displaying Information with the show spx Command.....	141
Using show commands for Operational Analysis.....	148
Campus Fabric mirroring overview.....	149
Mirroring in a Campus Fabric domain.....	149
MIB support for Campus Fabric 802.1br SPX configurations.....	151
<b>Campus Fabric Troubleshooting.....</b>	<b>153</b>
Enabling and Using SPX Monitoring.....	153
System Validation of Network Changes.....	154
Sample show spx-mon Output Indicating Issues.....	155
Sample show spx-mon history Output.....	161

The SPX Monitoring PE Join Checklist.....	162
Troubleshooting PE Data Ports.....	162
Campus Fabric General Troubleshooting Checklist.....	164

# Preface

- Document Conventions..... 7
- Command Syntax Conventions..... 7
- Document Feedback..... 8
- RUCKUS Product Documentation Resources..... 8
- Online Training Resources..... 8
- Contacting RUCKUS Customer Services and Support..... 9

## Document Conventions

The following table lists the text conventions that are used throughout this guide.

**TABLE 1** Text Conventions

Convention	Description	Example
monospace	Identifies command syntax examples	<code>device(config)# interface ethernet 1/1/6</code>
<b>bold</b>	User interface (UI) components such as screen or page names, keyboard keys, software buttons, and field names	On the <b>Start</b> menu, click <b>All Programs</b> .
<i>italics</i>	Publication titles	Refer to the <i>RUCKUS Small Cell Release Notes</i> for more information.

## Notes, Cautions, and Safety Warnings

Notes, cautions, and warning statements may be used in this document. They are listed in the order of increasing severity of potential hazards.

### NOTE

A NOTE provides a tip, guidance, or advice, emphasizes important information, or provides a reference to related information.

### ATTENTION

An ATTENTION statement indicates some information that you must read before continuing with the current action or task.



### CAUTION

A CAUTION statement alerts you to situations that can be potentially hazardous to you or cause damage to hardware, firmware, software, or data.



### DANGER

A DANGER statement indicates conditions or situations that can be potentially lethal or extremely hazardous to you. Safety labels are also attached directly to products to warn of these conditions or situations.

## Command Syntax Conventions

Bold and italic text identify command syntax components. Delimiters and operators define groupings of parameters and their logical relationships.

Convention	Description
<b>bold text</b>	Identifies command names, keywords, and command options.

## Preface

Document Feedback

Convention	Description
<i>italic text</i>	Identifies a variable.
[ ]	Syntax components displayed within square brackets are optional.
	Default responses to system prompts are enclosed in square brackets.
{ x   y   z }	A choice of required parameters is enclosed in curly brackets separated by vertical bars. You must select one of the options.
x   y	A vertical bar separates mutually exclusive elements.
< >	Nonprinting characters, for example, passwords, are enclosed in angle brackets.
...	Repeat the previous element, for example, <i>member</i> [ <i>member</i> ...].
\	Indicates a “soft” line break in command examples. If a backslash separates two lines of a command input, enter the entire command at the prompt without the backslash.

## Document Feedback

RUCKUS is interested in improving its documentation and welcomes your comments and suggestions.

You can email your comments to RUCKUS at [#Ruckus-Docs@commscope.com](mailto:#Ruckus-Docs@commscope.com).

When contacting us, include the following information:

- Document title and release number
- Document part number (on the cover page)
- Page number (if appropriate)

For example:

- RUCKUS SmartZone Upgrade Guide, Release 5.0
- Part number: 800-71850-001 Rev A
- Page 7

## RUCKUS Product Documentation Resources

Visit the RUCKUS website to locate related documentation for your product and additional RUCKUS resources.

Release Notes and other user documentation are available at <https://support.ruckuswireless.com/documents>. You can locate the documentation by product or perform a text search. Access to Release Notes requires an active support contract and a RUCKUS Support Portal user account. Other technical documentation content is available without logging in to the RUCKUS Support Portal.

White papers, data sheets, and other product documentation are available at <https://www.ruckuswireless.com>.

## Online Training Resources

To access a variety of online RUCKUS training modules, including free introductory courses to wireless networking essentials, site surveys, and products, visit the RUCKUS Training Portal at <https://training.ruckuswireless.com>.



# Contacting RUCKUS Customer Services and Support

The Customer Services and Support (CSS) organization is available to provide assistance to customers with active warranties on their RUCKUS products, and customers and partners with active support contracts.

For product support information and details on contacting the Support Team, go directly to the RUCKUS Support Portal using <https://support.ruckuswireless.com>, or go to <https://www.ruckuswireless.com> and select **Support**.

## What Support Do I Need?

Technical issues are usually described in terms of priority (or severity). To determine if you need to call and open a case or access the self-service resources, use the following criteria:

- Priority 1 (P1)—Critical. Network or service is down and business is impacted. No known workaround. Go to the **Open a Case** section.
- Priority 2 (P2)—High. Network or service is impacted, but not down. Business impact may be high. Workaround may be available. Go to the **Open a Case** section.
- Priority 3 (P3)—Medium. Network or service is moderately impacted, but most business remains functional. Go to the **Self-Service Resources** section.
- Priority 4 (P4)—Low. Requests for information, product documentation, or product enhancements. Go to the **Self-Service Resources** section.

## Open a Case

When your entire network is down (P1), or severely impacted (P2), call the appropriate telephone number listed below to get help:

- Continental United States: 1-855-782-5871
- Canada: 1-855-782-5871
- Europe, Middle East, Africa, Central and South America, and Asia Pacific, toll-free numbers are available at <https://support.ruckuswireless.com/contact-us> and Live Chat is also available.
- Worldwide toll number for our support organization. Phone charges will apply: +1-650-265-0903

We suggest that you keep a physical note of the appropriate support number in case you have an entire network outage.

## Self-Service Resources

The RUCKUS Support Portal at <https://support.ruckuswireless.com> offers a number of tools to help you to research and resolve problems with your RUCKUS products, including:

- Technical Documentation—<https://support.ruckuswireless.com/documents>
- Community Forums—<https://forums.ruckuswireless.com/ruckuswireless/categories>
- Knowledge Base Articles—<https://support.ruckuswireless.com/answers>
- Software Downloads and Release Notes—[https://support.ruckuswireless.com/#products\\_grid](https://support.ruckuswireless.com/#products_grid)
- Security Bulletins—<https://support.ruckuswireless.com/security>

Using these resources will help you to resolve some issues, and will provide TAC with additional data from your troubleshooting analysis if you still require assistance through a support case or RMA. If you still require help, open and manage your case at [https://support.ruckuswireless.com/case\\_management](https://support.ruckuswireless.com/case_management).



# About This Guide

---

- Supported hardware and software..... 11
- What's New in this Document..... 11

## Supported hardware and software

The following devices from the RUCKUS FastIron product family support Switch Port Extender (SPX) configurations:

- RUCKUS ICX 7150 Series
- RUCKUS ICX 7250 Series
- RUCKUS ICX 7450 Series
- RUCKUS ICX 7650 Series
- RUCKUS ICX 7750 Series
- RUCKUS ICX 7850 Series

For information about the specific models and modules supported in a product family, refer to the hardware installation guide for that product family.

## What's New in this Document

The following tables provide descriptions of information introduced in this guide for FastIron 08.0.95.

**TABLE 2** Summary of Enhancements in FastIron 08.0.95

Feature	Description	Location
ICX 7850 support	An ICX 7850 standalone or stack can form the control bridge (CB) for a Campus Fabric network.	Throughout the guide



# Campus Fabric Overview

---

- Campus Fabric..... 13
- FastIron Devices and Campus Fabric Communication..... 15
- Campus Fabric Roles and Communication Protocols..... 16
- Campus Fabric Data Path..... 17
- Campus Fabric Terminology..... 19

## Campus Fabric

Campus Fabric is sometimes referred to as Switch Port Extender (SPX).

Campus Fabric creates a more scalable architecture based on IEEE 802.1BR standards. RUCKUS Campus Fabric architecture adds ICX 7450, ICX 7250, or ICX 7150 devices configured as port extenders (PEs), or PE units, to a set of ICX 7650, ICX 7750, or ICX 7850 stack units configured as the control bridge (CB). The CB stack must contain units of the same model family but can contain different stackable SKUs for that model family.

The CB provides a single point of management for the extended network. Active and standby controller functions are retained and continue to provide hitless recovery as well as extended administrative functions. Campus Fabric greatly increases the number of access devices that the network can support. The distributed CB at the center of Campus Fabric architecture manages PE units and hundreds to thousands of ports at the network edge.

PE units are standards-based devices. Typically lower in cost, PE units rely on the CB for most network functions. As the network expands, new PE units can be detected and added to the network automatically using defined Campus Fabric communication protocols. PE units also inherit Premium-license features from the CB, which further reduces cost.

Campus Fabric architecture simplifies network management by unifying core, aggregation, and access functions. As illustrated in the following figure, a core stack (distributed chassis) serving as the CB connects to downstream Campus Fabric (PE) units that aggregate large numbers of access devices.

FIGURE 1 Campus Fabric Domain Build-out from a CB Stack

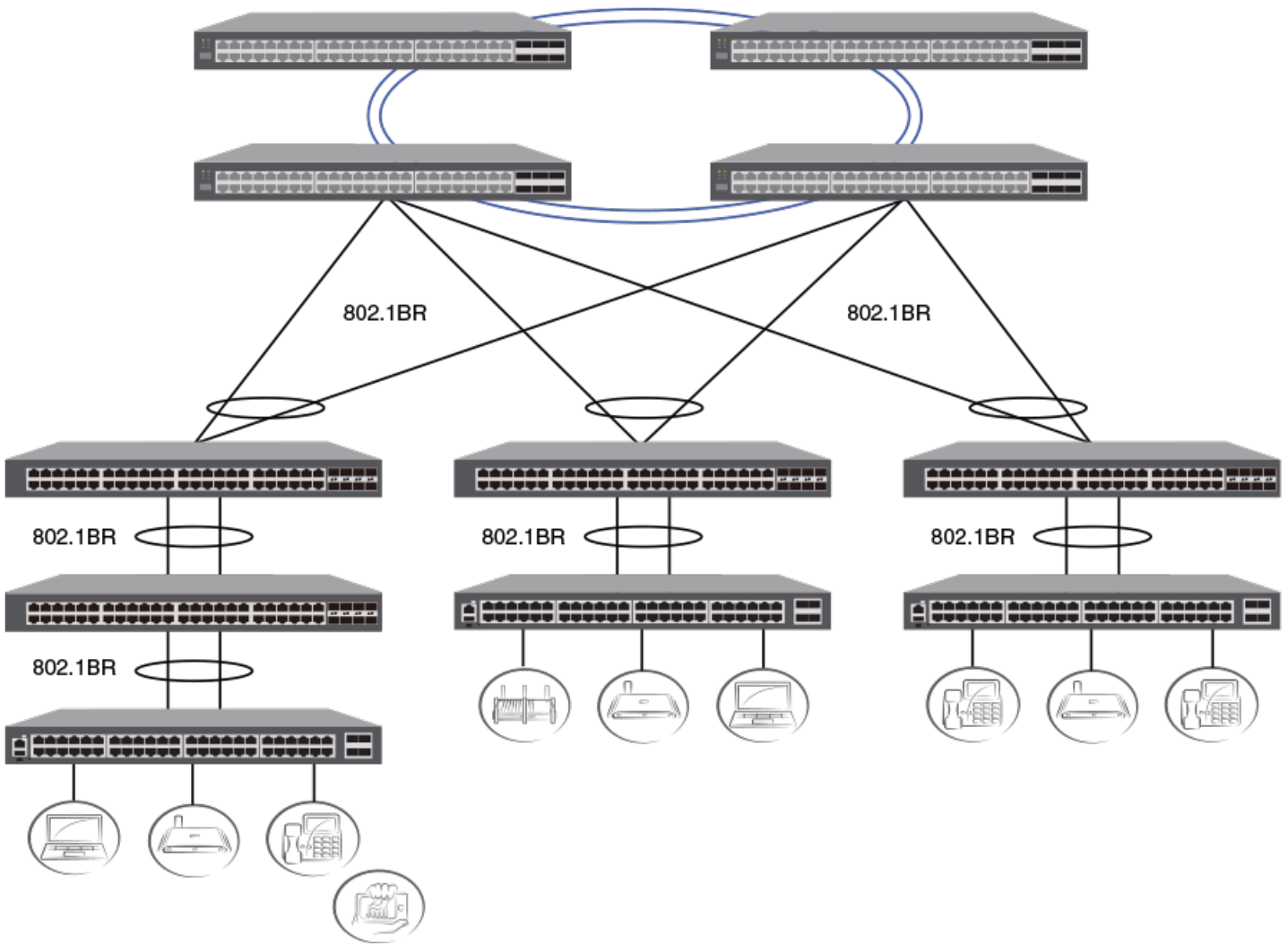

The following figure depicts three separate campuses, each with its own Campus Fabric domain, interconnected with a high-speed backbone.

**FIGURE 2** Distributed Campus Network Formed from Connected Campus Fabric Domains

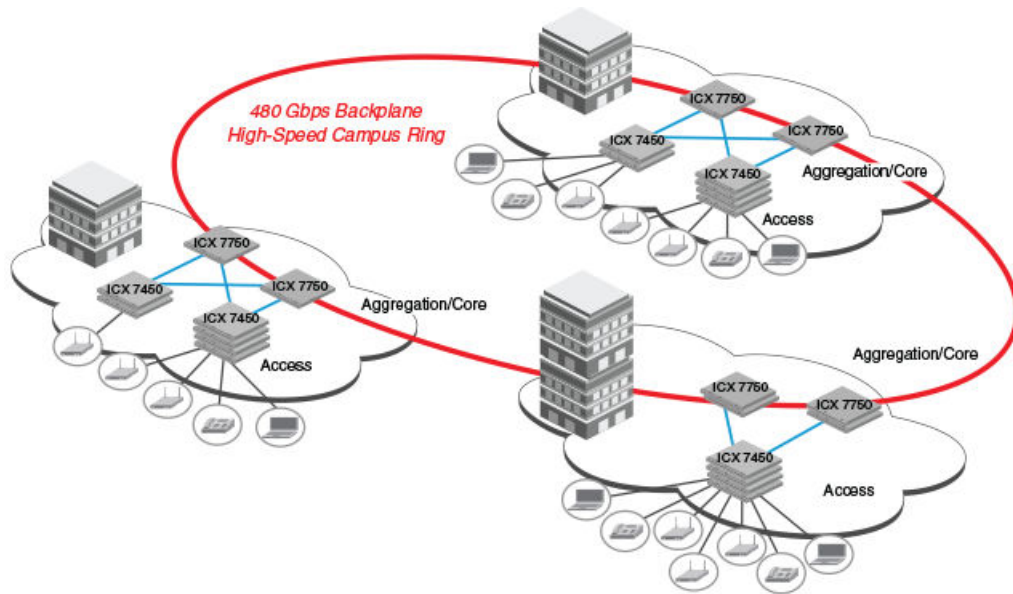

## FastIron Devices and Campus Fabric Communication

An ICX 7650, ICX 7750, or ICX 7850 stack or standalone serves as the control bridge (CB) for attached ICX 7450, ICX 7250, or ICX 7150 devices configured as port extender (PE) units. The PE units provide connectivity to PCs, laptops, IP phones, and other access devices.

The CB communicates with the attached PE units downstream using protocols defined in the IEEE 802.1BR standards. PE units in the extended topology tag packets from attached user devices and send the packets upstream to the CB for switching and network management.

**FIGURE 3** CB-to-PE Communication

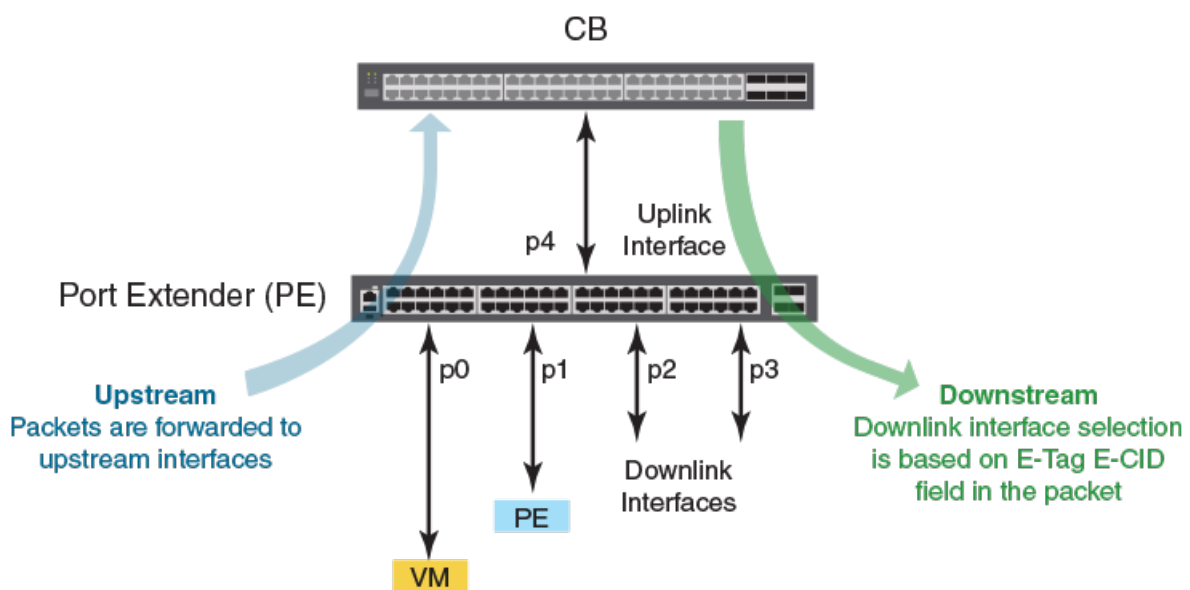

The simplified network topology with centralized control and lower-cost PE devices expands capacity by hundreds of additional access ports.

**NOTE**

FastIron 08.0.95 has been validated for approximately 1700 PE ports in a single Campus Fabric domain.

## Campus Fabric Roles and Communication Protocols

The control bridge (CB) creates, deletes, and manages port extender (PE) ports. It performs switching, routing, and forwarding for PE ports and provides centralized policy management.

The CB uses the Link Level Discovery Protocol (LLDP) to discover PE units. When the CB discovers a PE unit, it connects to the PE unit and creates a control plane using Control and Status Protocol (CSP) over the uplink/cascade port.

Each PE port is managed as a virtual port from the CB perspective. The CB sets up each PE unit for traffic forwarding and creates multicast and unicast forwarding tables through CSP.

The PE provides a data path between end hosts and the CB and uses LLDP to advertise 802.1br capabilities to the CB over the upstream port or LAG. If capabilities match, the PE uses CSP to attach to the CB. The PE reports the number of available ports to the CB, and the CB allocates an E-CID for each PE port. The PE also performs hardware-based multicast and broadcast replication.

**NOTE**

E-tag packets are assigned EtherType 0x893f.

As illustrated in the following figure, the access PE unit assigns an E-tag that is based on the configured ingress port to traffic forwarded upstream. E-tags provide downlink-to-uplink association. Transit PE units do not assign or change E-tags. PE downstream forwarding is based on the E-CID fields in the E-tags. The E-tag is removed by the access PE unit at the last hop downstream.

**FIGURE 4** E-tags Added Upstream and Removed at the Last Downstream Hop

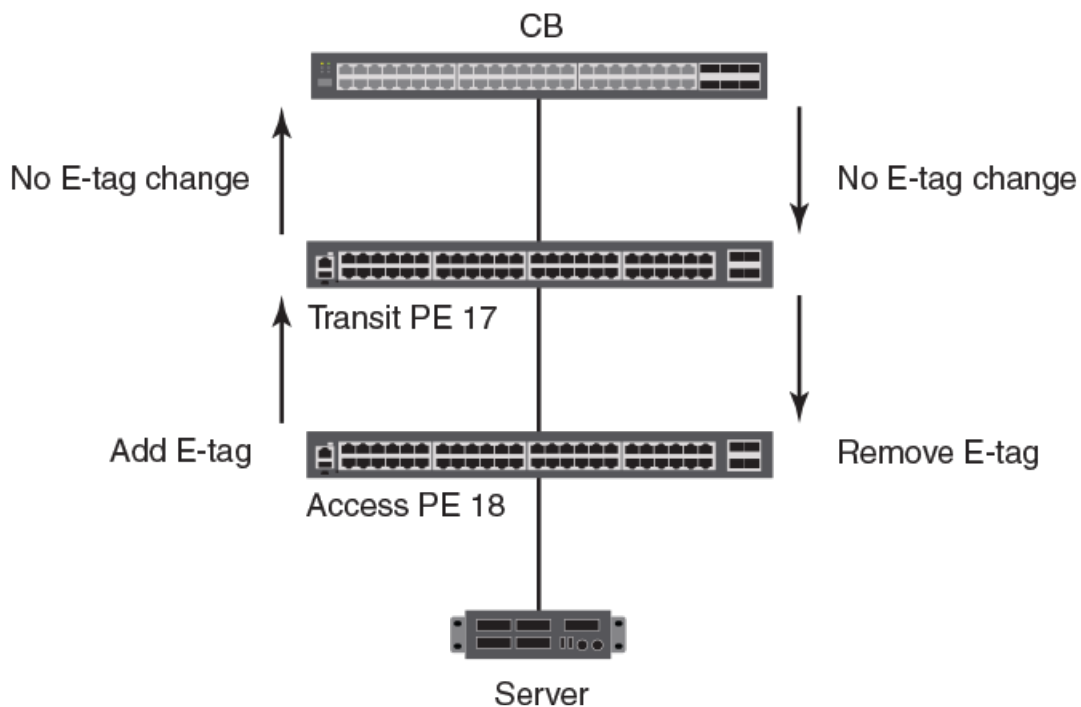



The bidirectional path between the external extended port and the corresponding internal extended port is referred to as an E-channel. E-channels are identified by the E-channel ID (E-CID) in the E-tag (channel range 0x00 0001 to 0x3F FFFE). E-channels can be point-to-point, point-to-multipoint, or multipoint-to-point.

## Control and Status Protocol

Control and Status Protocol (CSP) runs between the CB and attached PE units and is used to bring the PE units up or down.

PE CSP executes as an upper layer protocol over the Edge Control Protocol (ECP). ECP provides acknowledgment and retransmission of packets. PE CSP assumes that once a protocol data unit (PDU) is delivered to ECP, the PDU is reliably delivered to its peer.

**FIGURE 5** Campus Fabric Communication Protocol Hierarchy

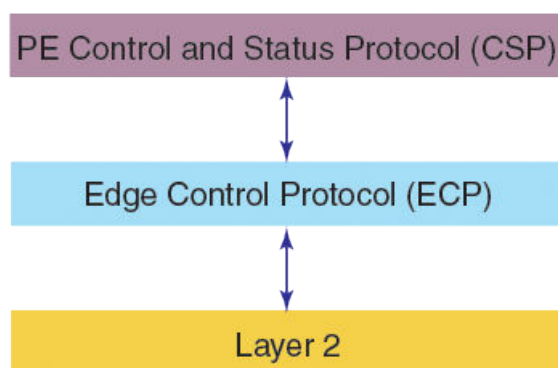

PE CSP is implemented as a simple command and response protocol with protocol information packaged in Type-Length-Value (TLV) triplets. Each PE CSP PDU consists of a command TLV and zero or more additional TLVs. A separate control E-channel is created between the CB and PE unit to carry PDUs, and a single instance of CSP runs between the PE unit and the CB.

## Campus Fabric Data Path

To understand packet flow in a Campus Fabric system, consider what happens when one host pings another through the Campus Fabric network. In the following figure, both hosts are connected to the same PE unit.

FIGURE 6 Campus Fabric Data Path Example

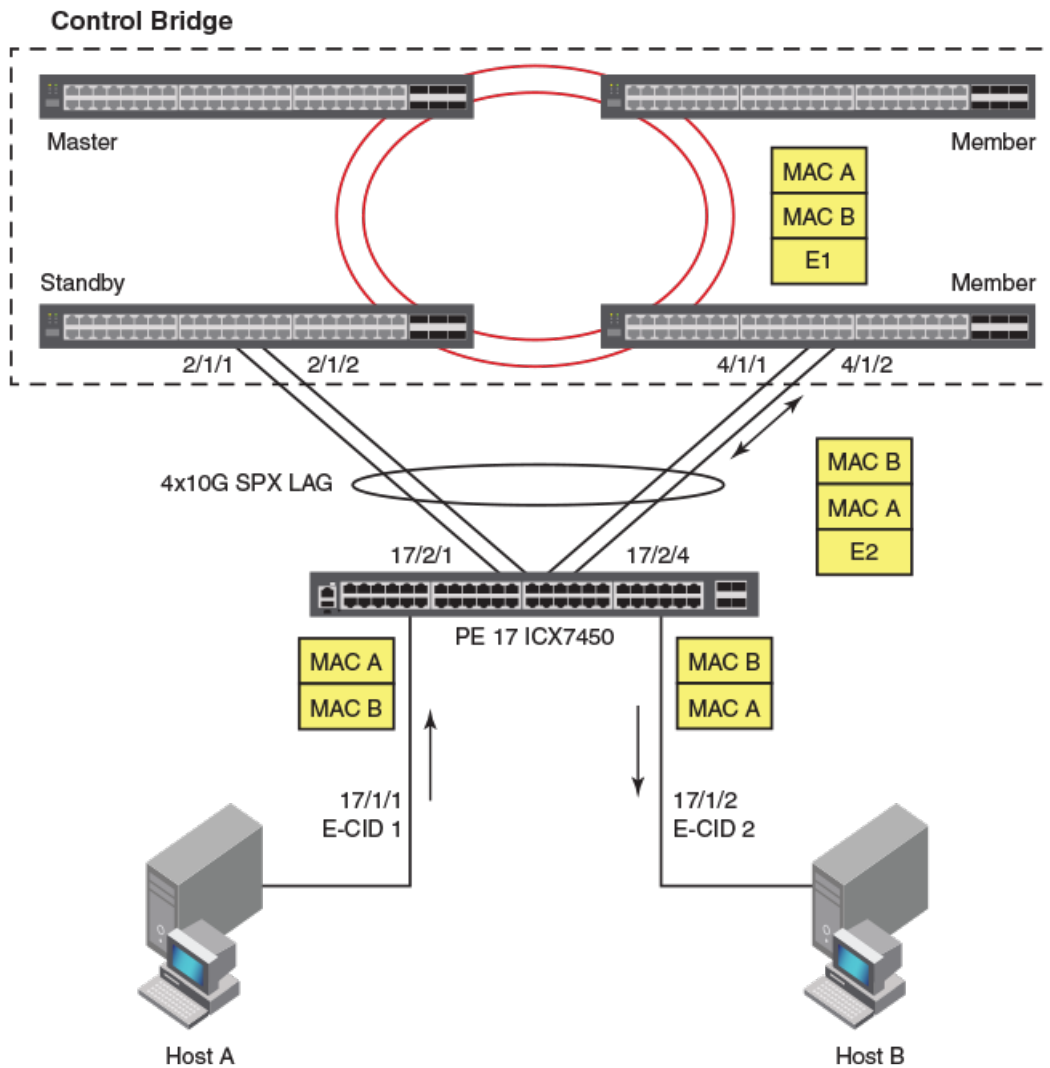

The following steps describe the series of events required for Host A to communicate with Host B.

1. Host A pings Host B.
2. The packet sent by Host A travels over port 17/1/1 to access PE unit 17, where an E-tag with the E-CID 1 is added. (The CB assigned this E-channel ID to the PE port when it was initialized.)
3. PE unit 17 sends the packet to the CB over the Campus Fabric uplink, the SPX LAG. The packet can traverse any of the available links in the LAG. In this example, the packet leaves the PE on port 17/2/4, which is connected to an ICX unit with member status in the Control Bridge stack.
4. The receiving CB unit looks up the destination address (MAC B) and associates it in forwarding tables with port 17/1/2. The CB adds E-CID 2 (which is the E-channel ID for port 17/1/2) to the packet and sends it back out to PE unit 17 over the SPX LAG.

**NOTE**

If the destination IP address is not already present in the CB forwarding tables, the packet is forwarded to the master CB unit (the active controller) to perform necessary Address Resolution Protocol functions. Once the MAC address of the destination is known, the forwarding tables are updated across all CB member switches to facilitate local forwarding of future packets destined for Host B. The same process is used for all Layer 2 and Layer 3 control packets.

If relevant Layer 2 and Layer 3 information is present in forwarding tables, any member of the CB stack can directly forward a packet to its destination without consulting the CB active controller.

5. PE unit 17 looks up E-CID 2 and matches it with port 17/1/2. The PE unit removes the E-tag and sends the ping packet to Host B over port 17/1/2.

## Campus Fabric Terminology

The following illustration provides a visual description of key Campus Fabric terms.

FIGURE 7 Visual Representation of Campus Fabric Network Terms

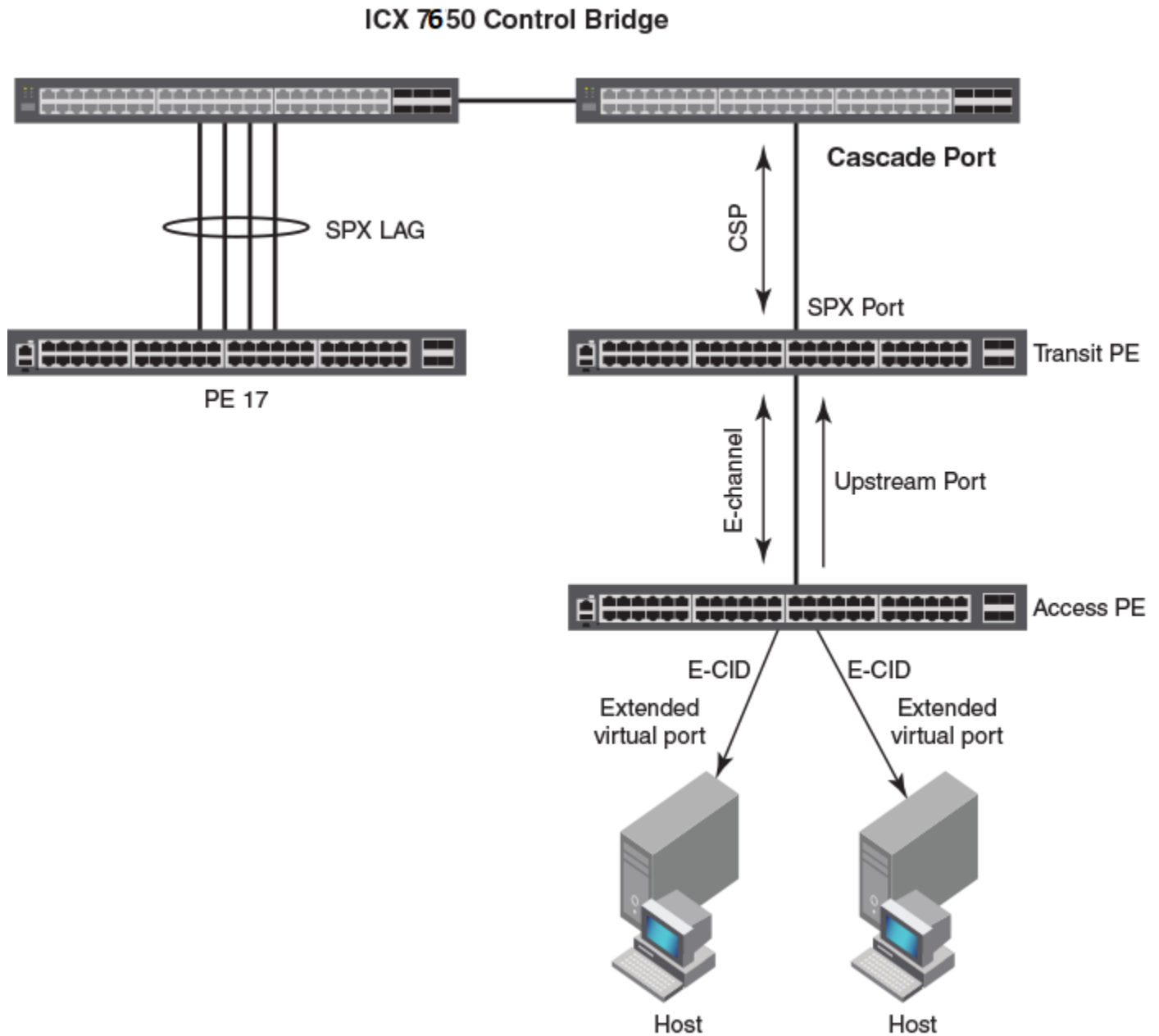

The following table defines terms specific to Campus Fabric.

TABLE 3 Campus Fabric Terminology

Term	Meaning
access (or base) port extender	A port extender (PE) connecting to end hosts. An access PE is located at the end of the CB-PE tree.
cascade port	An egress CB port connecting to a PE. (The link between the cascade port and the PE port is configured and displayed as an SPX port or SPX LAG.)
CB port	A control bridge (CB) port on a standalone or a stacking system. A CB port can be on any device in a stacking system.

**TABLE 3** Campus Fabric Terminology (continued)

Term	Meaning
control bridge	The control bridge (CB) has ports that link to one or more port extender (PE) units. The CB handles traffic to and from PE ports as if these ports were local ports. The control bridge can consist of an ICX 7650, ICX 7750, or ICX 7850 standalone or stack.
clean unit	A clean unit is a device running switch/router mode that has no startup_config flash during bootup and currently has no startup_config. (That is, the <b>write memory</b> command has never been executed on the unit.) You can execute the <b>erase startup</b> command followed by the <b>reload</b> command without executing the <b>write memory</b> command to make a unit to a new unit. A clean unit does not have a password. A clean unit must not contain <b>stack enable</b> or <b>spx cb-enable</b> configuration.
CSP	Control and Status Protocol. CSP serves as the Campus Fabric communication protocol between the CB master and the PE units in its control plane.
downstream port	A PE port that transmits traffic away from the CB, toward the access PE. A downstream port is an "egress" port from the perspective of the CB.
E-channel	The bidirectional path between the external extended port and the corresponding internal extended port. Each E-channel is identified by an E-channel ID (E-CID) in the E-tag (ranges from 0x0001 to 0x3FFF). E-channels can be point-to-point, point-to-multipoint, or multipoint-to-point.
E-CID	E-channel identifier. An E-CID identifies the PE destination port in CSP.
E-tag	A tag added to SPX packets. The E-tag contains an E-CID.
extended port	A PE port that serves as an access port to a host. Internal extended ports provide connectivity to the ports of the C-VLAN component. External extended ports operate as ports of the extended bridge. Each internal extended port is linked through an E-channel to an external extended port. Additional E-channels provide linkage between an internal extended port and multiple external extended ports in support of multicast frame delivery.
LLDP	Link Level Discovery Protocol. LLDP is the Layer 2 protocol used by the CB to discover and connect to PEs.
master (active controller)	The master of a CB stack. The entire stack is considered one logical device.
ME-CID	Multicast E-channel Identifier. Inserted in the E-tag, it carries a value of 0x1000 to 0x3FFF to indicate a multicast channel.
PE	Port extender. A PE, or PE unit, is a dummy device that contains multiple ports (for example, 24 or 48 ports). A PE forwards all traffic to the connected control bridge (CB). The PE does not perform local switching. The PE can connect to any unit in the CB.
PE mode	A special bootup role that causes a unit to perform as a dummy device. A unit in PE mode does not parse startup_config flash during bootup. It runs protocols, such as LLDP, only available to a PE. In PE mode, the unit does not perform local switching. Most commands and configurations are blocked.
Provisional-PE mode	A temporary mode created when a user configures the <b>spx pe-enable</b> command on a unit but has not yet reloaded the unit. Because the unit previously booted up in regular mode, it continues to perform as a regular device until the next reload. That is, the unit still acts like a regular switch or router. Most commands and configurations are blocked the same way as in PE mode.
regular mode	Normal or non-SPX mode. Regular mode describes a standalone unit that behaves like a normal switch or router.
reserved configuration	An SPX unit or stack unit that is configured and appears in output for the <b>show running-config</b> command, but which does not physically exist.
SPX	Switch Port Extender. SPX capability, also known as Campus Fabric, is based on IEEE 802.1BR standards and recommendations.
SPX port	A port on a PE that links to the CB or another PE. SPX port is a general term for PE ports and cascade ports. The <b>spx-port</b> command is used in CLI configuration to configure either a cascade port or an SPX port.
SPX LAG	A trunk that contains at least two SPX ports. (Cascade ports may be included in an SPX LAG.)
standalone	An individual unit that is not part of a stacking system. A standalone ICX 7650, ICX 7750, or ICX 7850 (or stack) can be enabled as an 802.1br control bridge.
TLV	Type-Length-Value information. CSP packets consist of a command TLV and can contain additional TLVs.
transit PE	A PE that is not an access PE. A transit PE aggregates transmissions from downstream PEs.

**TABLE 3** Campus Fabric Terminology (continued)

Term	Meaning
upstream port	A PE port that connects to a transit PE toward the CB or directly to the CB. An upstream port is an "ingress" port from the perspective of the CB.

# Planning Considerations for a Campus Fabric Domain

---

- Campus Fabric Licensing..... 23
- Handling SPX Links with Different Speeds..... 24
- Campus Fabric Scalability..... 24
- SPX Port Combinations..... 25
- Control Bridge Considerations..... 26
- Port Extender Considerations..... 27
- Campus Fabric Topology Overview..... 28

## Campus Fabric Licensing

No licenses are required for Campus Fabric (802.1br, or SPX); however, ICX 7150 and ICX 7250 devices used as PE units require licenses to bring up ports at 10 Gbps, including SPX links. In addition, ICX 7650 or ICX 7850 devices used as CB units require a Layer 3 premium license to enable Layer 3 premium features and a MacSec license to enable the MACSec feature.

### NOTE

All ICX devices support trust-based licensing through Self Authenticated Upgrade (SAU). Installation is simplified, and related commands differ from previous license installation commands. For details on licensing, refer to the *RUCKUS FastIron Software Licensing Guide*.

## Premium Licenses for ICX 7650 or ICX 7850 CB Units

ICX 7650 or ICX 7850 devices operating as CB units require premium licenses to support Layer 3 premium features. Each ICX 7650 or ICX 7850 unit in a CB stack must have a Layer 3 premium license installed.

## MACsec Licenses for ICX 7650 or ICX 7850 CB Units

MACsec is supported on ICX 7650 and ICX 7850 CB units if a valid feature license is installed.

## License Inheritance

If a premium license is enabled on a device in the CB, all ICX 7450, ICX 7250, or ICX 7150 devices attached to the CB and operating as PE units inherit premium license features.

## ICX 7150 and ICX 7250 Licenses

ICX 7150 and ICX 7250 Module 2 links run 1 Gbps by default without a license. To connect to a CB over a 10-Gbps SPX link, an ICX 7150 or ICX 7250 must have a 10-Gbps license installed.

### NOTE

ICX 7150-48ZP models ship with two 10-Gbps links; however, additional 10-Gbps ports require a license.

### NOTE

ICX 7150-C08P models do not have any 10-Gbps-capable ports.

Two-port or eight-port 10-Gbps licenses can be pre-loaded on ICX 7250 or ICX 7150 devices, or you can install SAU licenses as described in the *RUCKUS FastIron Software Licensing Guide*. If the licenses are not pre-loaded on ICX 7250 or ICX 7150 units connected to a Campus Fabric domain, the devices may form 1-Gbps SPX links that must be converted to 10-Gbps SPX links using the following procedure.

## Handling SPX Links with Different Speeds

Ports on CB units intended to provide SPX links and ports on PE units to which they are attached may be running different speeds. Refer to the procedures in [Changing the Speed on an SPX Link](#) on page 107 for related scenarios and procedures.

## Campus Fabric Scalability

A Campus Fabric domain can contain from 1 to 4 CB units. Each of the CB units can support a PE chain or ring of up to 6 units. The maximum number of PE units in a Campus Fabric domain is 36. Assuming 48-port ICX 7450, ICX 7250, or ICX 7150 devices are used as PE units, 1,728 ports are supported.

Campus Fabric domain maximum configuration can be summarized as follows:

- 4 CB units (ICX 7650, ICX 7750, or ICX 7850 stack)
- 32 ports per CB (32 X 4 for full CB stack)
- Maximum of 8 PE chains
- Maximum 16 stand-alone PEs (in addition to 8 PE chains)
- 36 PE units per domain
- 6 PE units per chain or ring
- 1 MB maximum configuration file size

The following figure illustrates a maximized Campus Fabric domain.



**FIGURE 8** Maximum Units in One Campus Fabric Domain

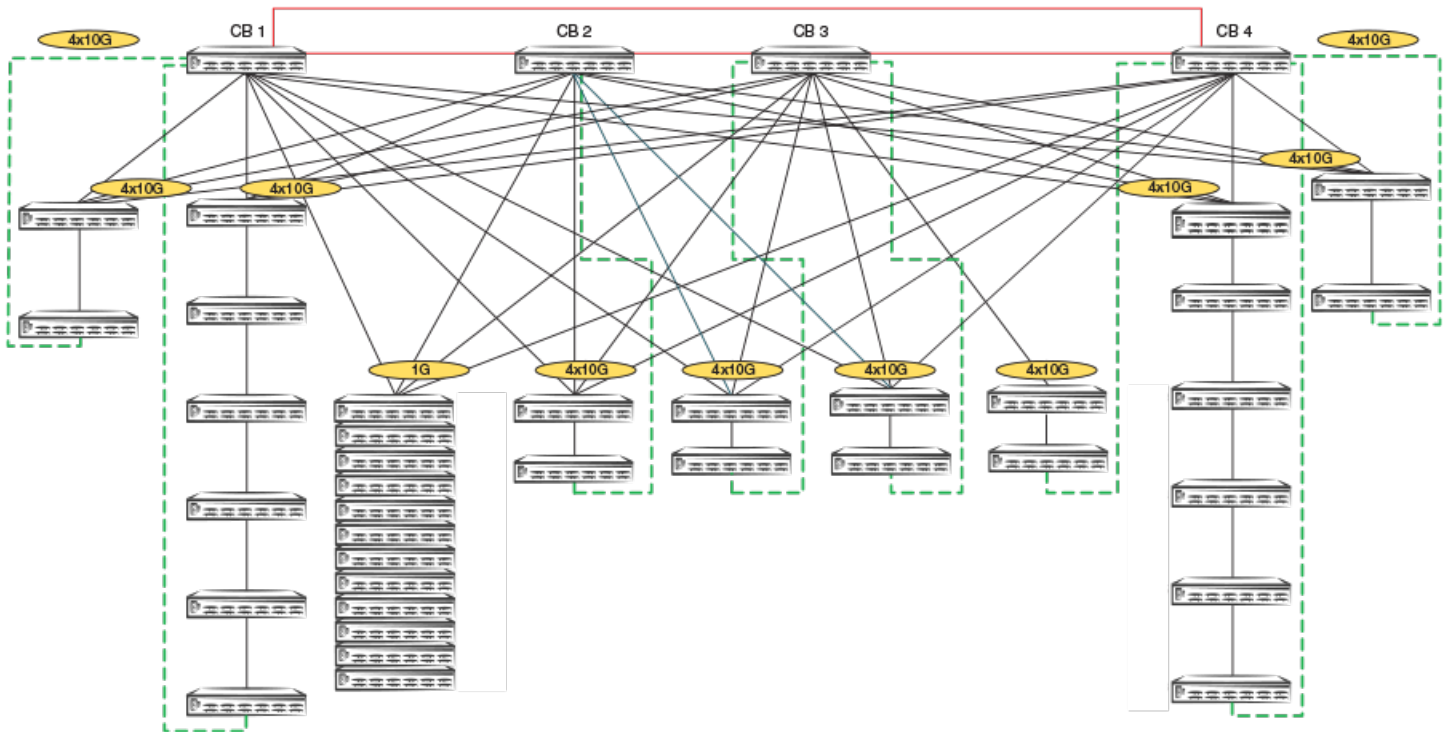

This is a fully scaled Campus Fabric setup with 4 CBs. All SPX connections shown are either 4 X 10-Gbps or 1-Gbps connections. The topology includes 8 SPX PE rings, which is the maximum validated scale. The PE rings are depicted with green dashed lines to contrast them with regular uplinks. In addition to PE rings, the topology contains 12 standalone PE units. The standalone PE units have redundant uplinks to all 4 CBs. This setup also contains two SPX PE rings with the maximum cascade depth of 6 PE units.

## SPX Port Combinations

Speeds on each end of an SPX link must match. The following tables provide valid SPX port combinations.

**NOTE**

If you have potential PE units connected downstream over 1-Gbps links to be converted to 10-Gbps SPX links, refer to [Converting 1-Gbps SPX Links on Downstream PEs to 10-Gbps Links](#) on page 108.

**NOTE**

1-Gbps connections between CB units and PE units are supported beginning from FastIron release 08.0.80.

**TABLE 4** Valid ICX 7750 CB-to-PE Port Combinations

CB port	PE port					
	40-Gbps QSFP (1x40Q module)	10-Gbps Fiber (4x10F module)	10-Gbps Copper (4x10T module)	1-Gbps Fiber (4x1F module)	1-Gbps Copper (base unit ports)	1-Gbps Fiber (base unit ports)
40-Gbps QSFP	Yes	No	No	No	No	No
10-Gbps Fiber	No	Yes	No	No	No	No
10-Gbps Copper	No	No	Yes	No	No	No
1-Gbps Fiber	No	No	No	Yes	No	Yes

**TABLE 4** Valid ICX 7750 CB-to-PE Port Combinations (continued)

CB port	PE port					
1-Gbps Copper	No	No	No	No	Yes	No

**TABLE 5** Valid ICX 7850 CB-to-PE Port Combinations

CB Port	PE Port						
	40-Gbps QSFP (1x40Q module)	10-Gbps Fiber (4x10F module)	10-Gbps Copper (4x10T module)	1-Gbps Fiber (4x1F module)	1-Gbps Copper (base unit ports)	1-Gbps Fiber (base unit ports)	2.5-Gbps (base unit ports)
40-Gbps QSFP	Yes	No	No	No	No	No	No
10-Gbps Fiber	No	Yes	No	No	No	No	No
10-Gbps Copper	No	No	No	No	No	No	No
1-Gbps Fiber	No	Yes	No	Yes	No	Yes	No
1-Gbps Copper	No	No	No	No	No	No	No
2.5-Gbps	No	No	No	No	No	No	No

**TABLE 6** Valid ICX 7650 CB-to-PE Port Combinations

CB Port	PE Port						
	40-Gbps QSFP (1x40Q module)	10-Gbps Fiber (4x10F module)	10-Gbps Copper (4x10T module)	1-Gbps Fiber (4x1F module)	1-Gbps Copper (base unit ports)	1-Gbps Fiber (base unit ports)	2.5-Gbps (base unit ports)
40-Gbps QSFP	Yes	No	No	No	No	No	No
10-Gbps Fiber	No	Yes	No	No	No	No	No
10-Gbps Copper	No	No	Yes	No	No	No	No
1-Gbps Fiber	No	No	No	Yes	No	Yes	No
1-Gbps Copper	No	No	No	No	Yes	No	No
2.5-Gbps	No	No	No	No	No	No	Yes

**TABLE 7** Valid PE-to-PE Port Combinations

PE Port 1	PE Port 2						
	40-Gbps QSFP (1x40Q module)	10-Gbps Fiber (4x10F module)	10-Gbps Copper (4x10T module)	1-Gbps Fiber (4x1F module)	1-Gbps Copper (base unit ports)	1-Gbps Fiber (base unit ports)	2.5-Gbps Copper (base unit ports)
40-Gbps QSFP	Yes	No	No	No	No	No	No
10-Gbps Fiber	No	Yes	No	No	No	No	No
10-Gbps Copper	No	No	Yes	No	No	No	No
1-Gbps Fiber	No	No	No	Yes	No	Yes	No
1-Gbps Copper	No	No	No	No	Yes	No	No
2.5-Gbps	No	No	No	No	No	No	Yes

## Control Bridge Considerations

Keep the following considerations in mind when configuring Campus Fabric:

- To be used in a Campus Fabric configuration, an ICX 7650, ICX 7750, or ICX 7850 device must be running a router image.
- An ICX 7650, ICX 7750, or ICX 7850 stack or a standalone ICX 7650, ICX 7750, or ICX 7850 device can be enabled as a CB.
- A traditional stack that serves as a CB stack in a Campus Fabric domain can contain no more than 4 units.

- A stack that serves as the CB can be configured in the same way as any traditional stack. A separate SPX interactive-setup utility is available for configuring an SPX domain when zero-touch provisioning is not appropriate.
- ICX 7650 devices support SPX ports only on Module 1 or Module 2.
- To be operational, a Campus Fabric configuration requires correct CB-PE SPX port or SPX LAG configuration.
- If Spanning Tree Protocol (STP) is enabled on a CB, the CB must be reloaded for previous spanning tree configuration to be available.

For more information on maximum CB connections, refer to [Campus Fabric Scalability](#) on page 24.

## Port Extender Considerations

Keep the following points in mind when configuring PE units:

- All ICX 7150 models except the ICX 7150-C08P can be enabled as PE units.
- All ICX 7250 models except the ICX 7250-24L can be enabled as PE units.
- All ICX 7450 models, including ICX 7450-32ZP devices, can be enabled as PE units.
- When the CB consists of ICX 7850 switches, PE ports cannot be connected to the service provider network.
- In a Campus Fabric domain, no local switching occurs on the PE ports. All data and control packet processing occurs in the CB. No IP addressing is possible on the physical PE ports; however, virtual interfaces (VEs) are supported.
- Client-facing LAGs are not supported over PE virtual ports.
- Units in a stack must be disconnected, and stacking must be disabled before the units can be enabled as PEs. Likewise, if a standalone unit is enabled for stacking, stacking must be disabled before the unit can be enabled as a PE.
- Only standalone units running a router image can be enabled as PE units. Although PE units cannot run a switch image, if a TFTP server with the appropriate router image is connected to the Campus Fabric domain and a path to the image is provided, the CB will upgrade the PE image automatically. Refer to [Campus Fabric \(SPX\) Image Upgrade](#) on page 133. The converted unit can retain a stacking configuration and can later be reloaded with a switch image, if necessary.
- PE units can join a Campus Fabric domain only after at least one working SPX port or SPX LAG has been configured on both the CB and PE. Once a PE is enabled and configured, you must use the **write memory** and **reload** commands to complete initialization.
- Each PE unit can have no more than two SPX connections, one upstream connection toward the CB and one downstream connection to another PE unit. These connections can be two SPX links, two SPX LAGs, or one SPX link and one SPX LAG. Only one SPX connection is allowed between two PE units.
- No speed negotiation is possible over an SPX connection. The speed at both ends of an SPX connection must be the same.

### NOTE

To convert a 1-Gbps SPX link on ICX 7150 or ICX 7250 devices to a 10-Gbps SPX link, you must disable the SPX link or LAG and change speed at both ends before re-enabling the SPX link or LAG. For more information, refer to [Converting 1-Gbps SPX Links on Downstream PEs to 10-Gbps Links](#) on page 108.

- Allowable PE IDs are from 17 through 56.

### NOTE

FastIron does not support BUM rate-limiting on PE ports in an SPX environment.

For information on supported and unsupported topologies, refer to [Campus Fabric Topology Overview](#) on page 28.

For information on PE unit and PE port scaling, refer to [Campus Fabric Scalability](#) on page 24.

## Campus Fabric Topology Overview

The basic Campus Fabric topology consists of a single control bridge (CB) that operates within a core stack connected to one or more port extender (PE) units.

The CB stack consists of a maximum of four ICX 7650, ICX 7750, or ICX 7850 units connected in a linear or ring topology. PE units are specially configured ICX 7450, ICX 7250, or ICX 7150 units that are connected to the CB. The PE units can be connected to each other over a single SPX port or LAG to form a PE chain or ring. The PE chain or ring can contain a combination of ICX 7150, ICX 7250, or ICX 7450 units.

In the following figure, four ICX 7650 units are configured in a ring stack form the CB. Three of the CB units are connected to PE units (PE 17, 18, and 19).

**FIGURE 9** Control Bridge Ring with Attached PE (SPX) Units

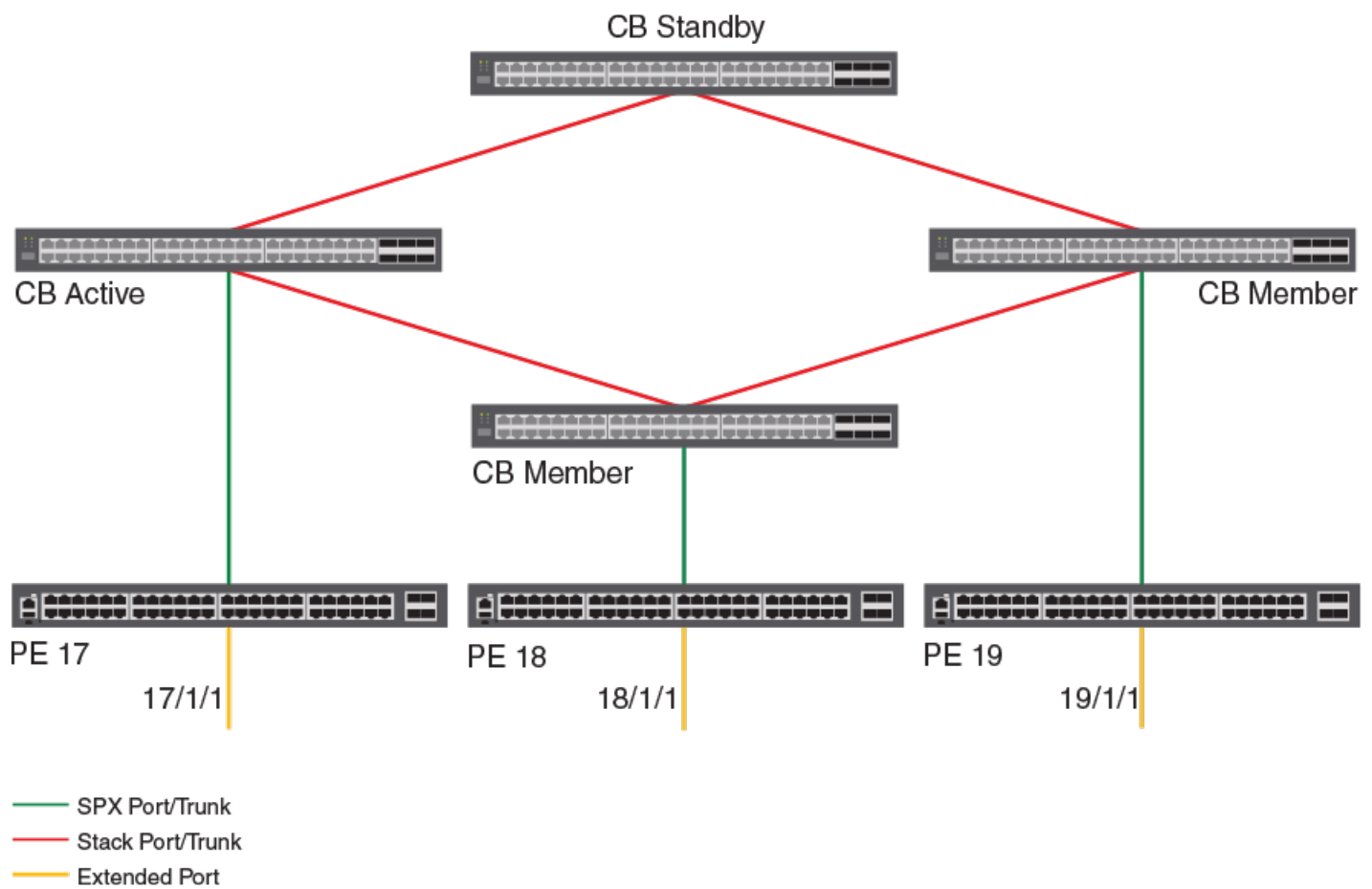

In the following figure, three of the ICX 7650 CB units are connected to PE units. The directly connected PE units (cascade PEs) are connected to additional PE units to form an SPX chain, also referred to as a PE chain. Each SPX chain in the figure contains three PE units.

**FIGURE 10** Control Bridge Ring with Multiple PE (SPX) Chains

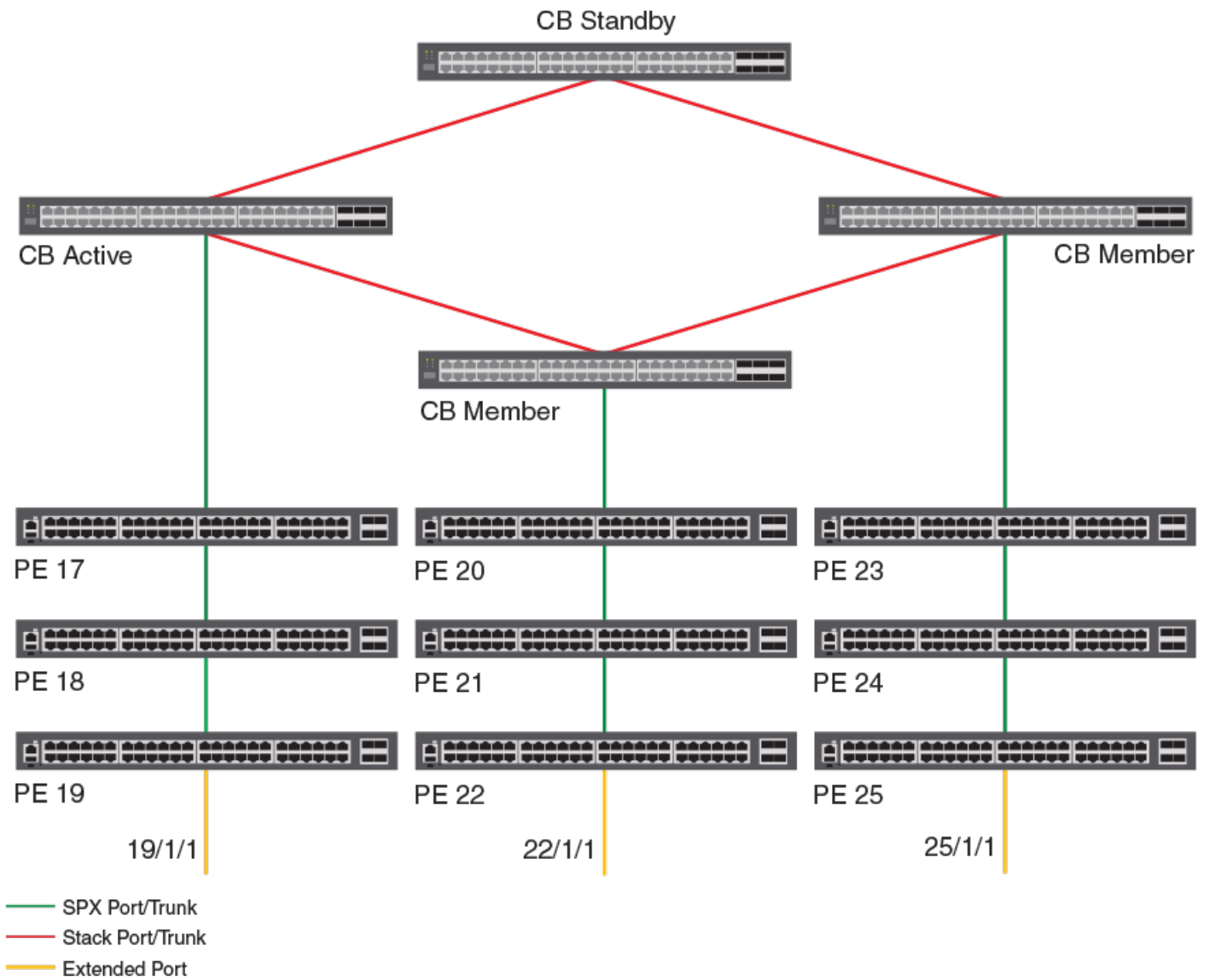

## Rules Governing Campus Fabric Topology

A Campus Fabric domain can be discovered and automatically configured in some cases and interactively configured in other cases. Understanding the rules that apply to supported topologies will help you configure or modify the Campus Fabric domain.

**NOTE**

Zero-touch configuration and interactive setup are covered in [Campus Fabric Configuration Overview and Interactive Configuration](#) on page 41.

The following rules apply to supported Campus Fabric topologies:

- A PE unit can have a maximum of two SPX port or SPX LAG connections.
- CB units can have many SPX ports and LAGs.

- An SPX LAG can contain from 2 to 16 ports. For ICX 7650, ICX 7750, or ICX 7850 CB units, ICX 7450 PE units, and ICX 7250 PE units, the maximum number of ports in an SPX LAG is 16 ports. For PE units that are ICX 7150 devices, the maximum ports in an SPX LAG is 8 ports.
- Both ends of a link between a CB and a PE or between two PE units must be an SPX port or an SPX LAG.
- The CB must be able to reach any PE unit in a PE chain using the single SPX port or LAG. The CB must be able to reach any PE unit in a ring using either of the two SPX ports or LAGs.
- The maximum number of PE units in a chain or ring is six.
- An SPX LAG cannot link to multiple SPX ports or LAGs.
- A single PE unit cannot form a ring. An SPX LAG between the PE unit and the CB is recommended instead. If the system detects a single PE ring, one of the SPX ports or LAGs will be disabled to break the ring.

## Supported CB-PE LAG Topologies

One PE unit can be connected to more than one CB unit when the connection is configured as a single LAG. If one of the connected units in the CB fails, the PE unit still maintains a connection to the CB. In the following figure, SPX 17 is connected to more than one CB unit by a single LAG.

**FIGURE 11** Single SPX LAG Shared Across Multiple CB Units

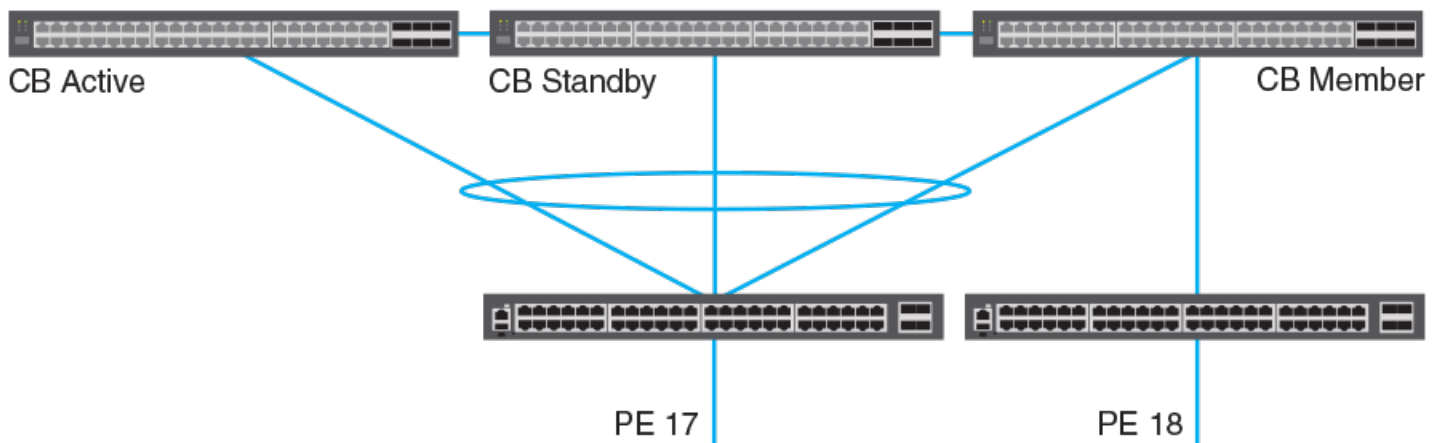

Other supported LAG topologies are shown in the following figures.

**FIGURE 12** CBs with a Multiple-port LAG to the Same PE

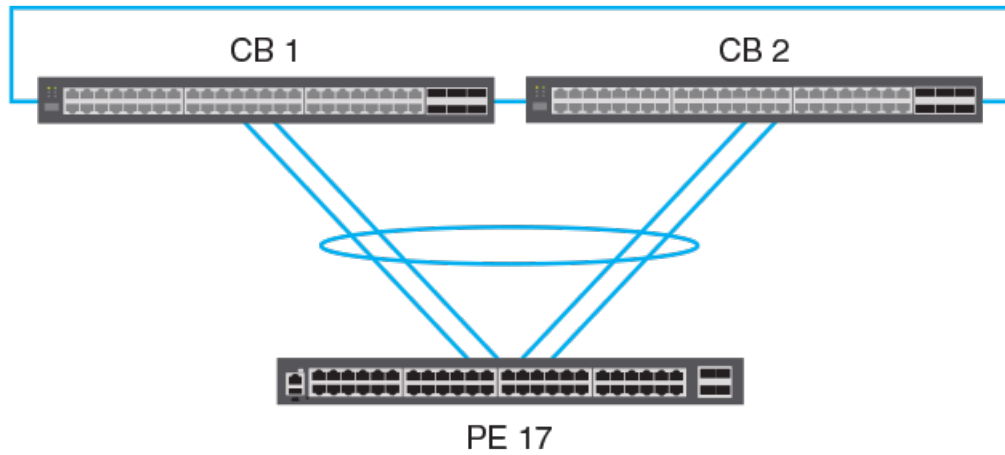

**FIGURE 13** CB-PE Shared LAG Containing an Unattached Data Link

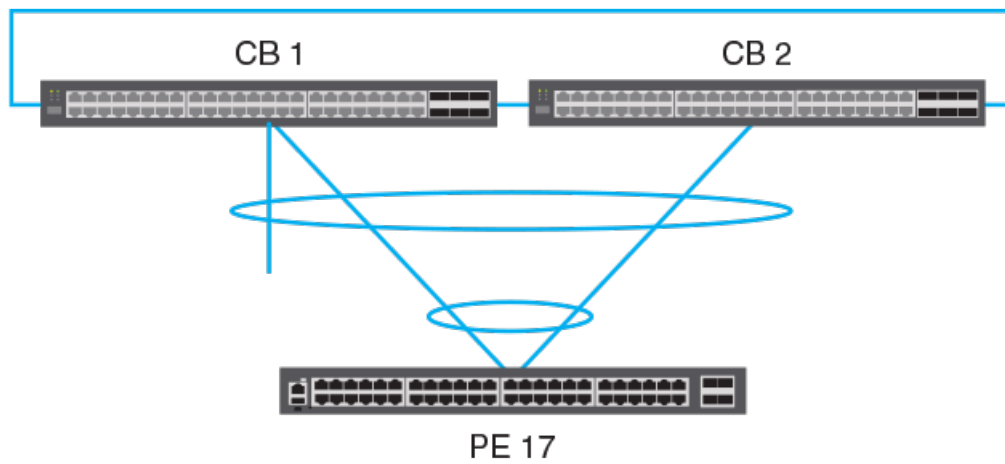

**NOTE**

While a non-matching SPX LAG is allowed, for example a topology that includes a three-port LAG to a two-port LAG link as shown in the previous figure, it may cause communication problems if the extra port is in the UP state. Use the **spx-lag** or **multi-spx-lag** command to correct the configuration.

**FIGURE 14** CBs Sharing a LAG to a Cascade PE in a Chain

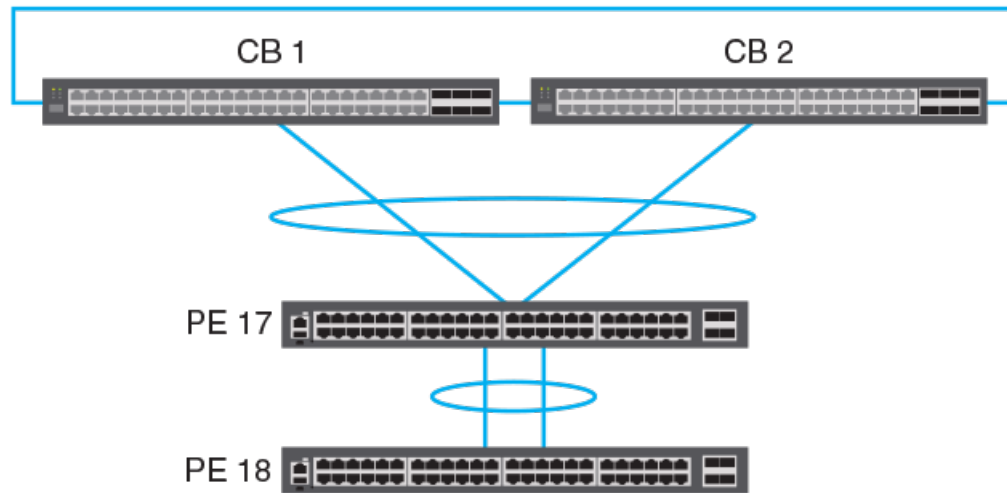

**FIGURE 15** CBs Sharing LAGs to Both Cascade PEs in Two Chains

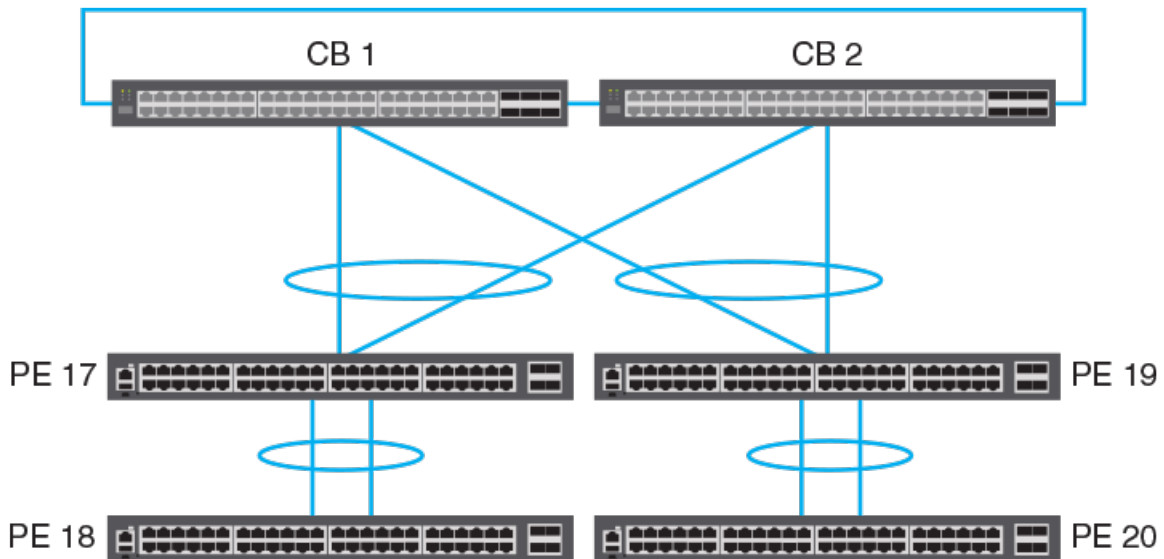

## Supported PE Ring Topology

A redundant SPX link can be connected from a CB unit to the edge PE of an existing PE chain or between two edge PEs of two existing PE chains to form a PE ring. You can combine ICX 7150, ICX 7250, and ICX 7450 devices in a PE ring just as you can in a PE chain. The following figure represents the allowable PE ring topology. When the ring is active, traffic is generally load-balanced over the two existing SPX links.



FIGURE 16 Supported PE Ring Topology

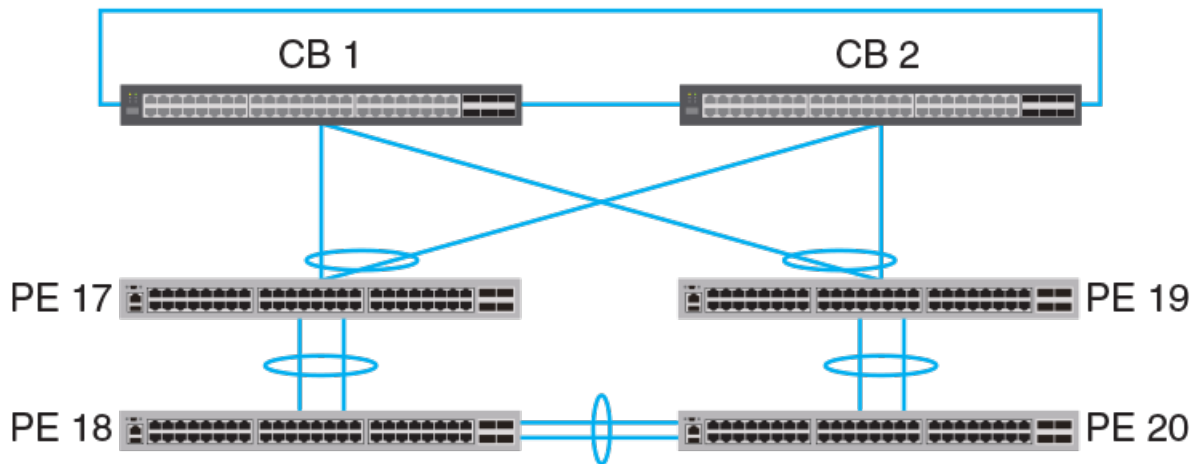

## PE Ring Topology Limitations

Consider the following points before configuring a ring topology:

- SPX links can be connected to the first (cascade) PE or the last PE in a PE chain. However, a PE ring cannot be formed by connecting an SPX link between two PEs of an existing chain.
- PE ring topology with one PE unit is not supported; a PE ring requires at least two PE units.
- PE ring topology supports a maximum of six PE units.

## Traffic Flow in a PE Ring Topology

In the following figure, the red arrow represents upstream traffic, that is, traffic originating through a PE extended port. Upstream traffic is sent to the CB for lookup and replication. The green arrow represents downstream traffic, that is, the traffic exiting through a PE extended port. The CB replicates downstream traffic on one or both of the SPX links, depending on the type of traffic.

The green 'X' between PE 18 and PE 29 illustrates the logical block in the active ring. The ring remains up, but downstream traffic is intentionally dropped at this point to prevent the traffic from traveling back to the CB through a redundant SPX link. If the ring topology changes, the logical block may also move to a new point between two other PE units.

When the ring is active, each PE unit is mapped to one of the SPX links, and any known unicast traffic that flows through the PE uses the same SPX link until the ring breaks or the ring topology changes. If the ring breaks and the mapped SPX link is no longer reachable, a PE unit is remapped to the alternate SPX link, assuming it is reachable. (Traffic is lost only until reconvergence is complete.)

For multicast or BUM traffic, each PE unit is mapped to one of the SPX links to carry upstream traffic. All traffic downstream is carried on both SPX links. This duplication avoids remapping the PE unit when the ring breaks and allows for faster reconvergence following failover.

FIGURE 17 Information Flow in a PE Ring

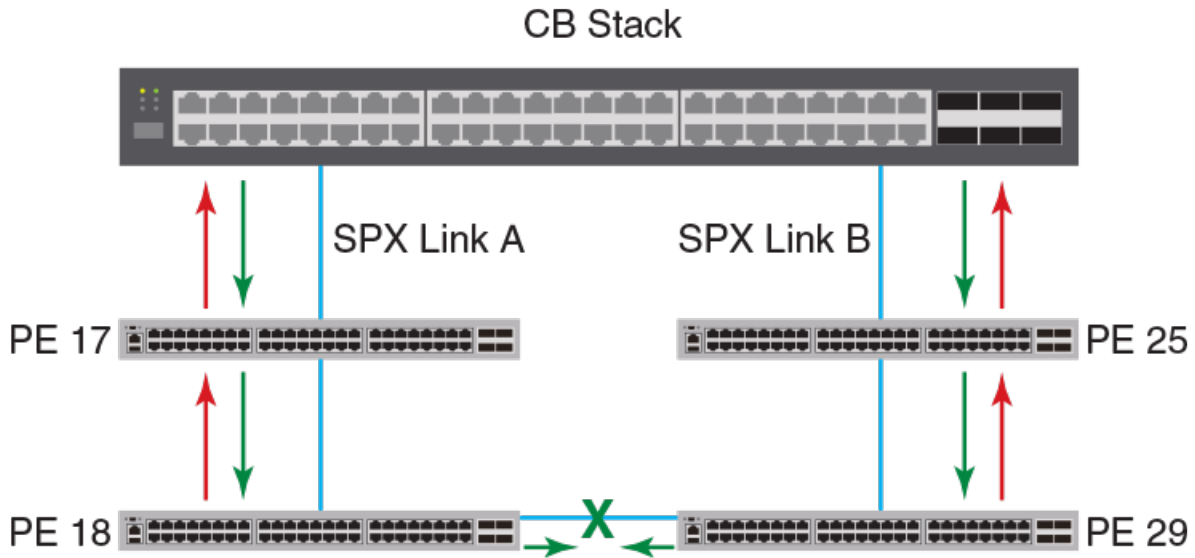

## Best Practices for PE Ring Configuration

There are two suggested methods for forming a PE ring from two PE chains. In both methods, you must form an SPX link by configuring an SPX port or SPX LAG on both ends of a connection and then physically link the cables.

The first method is to connect the edge PEs of two linear chains through an SPX link as shown in the following figure.

FIGURE 18 PE Ring Formed by Connecting Base Units

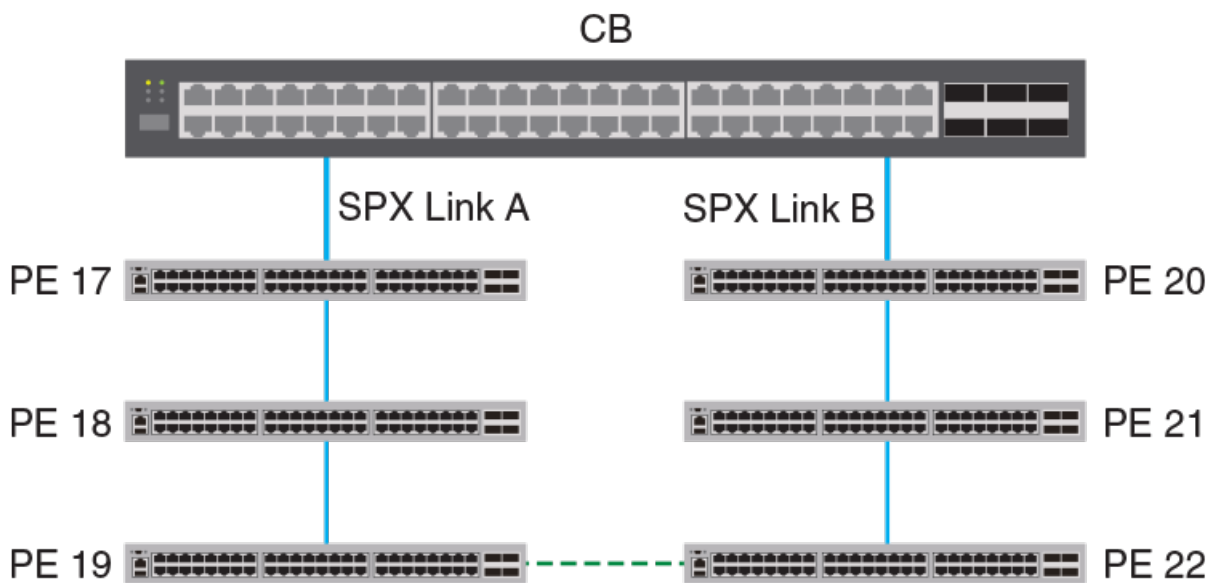

The second suggested method for creating a PE ring is to form an SPX link between the edge PE of an existing chain and the CB SPX cascade port as shown in the following figure.

FIGURE 19 PE Ring Formed through a CB-PE Cascade Port

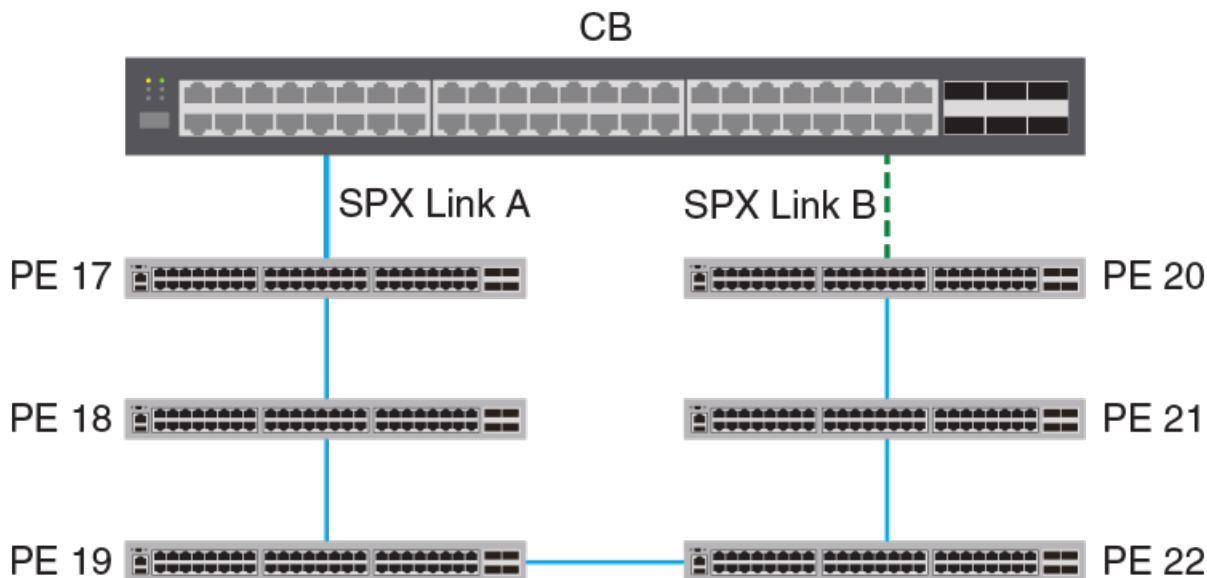

It is not necessary to configure a ring explicitly. Once you have connected the PEs to form a physical ring, the system is able to generate the correct **pe-id** configuration under **spx cb-configure**.

Once the topology learns about the PE ring, you can verify its presence with the **show spx** command. You can then check **show running-config** command output for **pe-id** configuration details for the ring (for example, pe-id CB-port 1 ID1 ID2 ... CB-port 2).

**NOTE**

A pe-id configuration in this format does not confirm the presence of a ring. Only the output from the **show spx** command does.

To avoid losing the configuration during a CB reboot, save it by executing the **write memory** command.

**NOTE**

SPX link events, PE timeouts, and PE reboots do not affect the ring topology stored in running configuration.

**NOTE**

For information on removing a ring, refer to [Removing a PE ring and its configuration](#) on page 119.

## Topologies Not Supported by Campus Fabric

Campus Fabric cannot be implemented on certain topologies.

If you attempt to configure a redundant link between a CB unit and a PE unit or between two PE units in a chain, the configuration is error-disabled because the second link creates a loop. Correct the problem by adding the second link to a single SPX LAG using the **multi-spx-lag** command.

The following figures illustrate redundant link configurations.

**FIGURE 20** Unsupported Configuration: Redundant Link between a CB and a PE

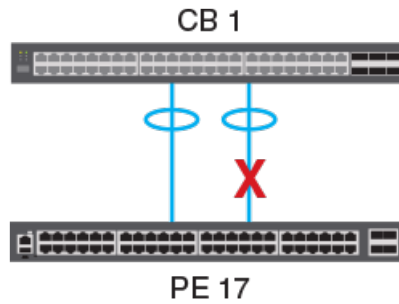

**FIGURE 21** Unsupported Configuration: Redundant Link between Two PE Units

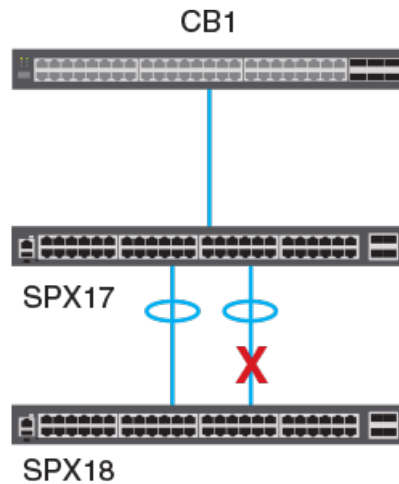

A PE unit can have only two SPX ports or LAGs. As a result, a PE unit cannot have two PE units directly attached downstream at the same level of the SPX chain. In the following figure, whichever unit, SPX 18 or SPX 19, joins first "wins" the connection. When the remaining PE candidate attempts to join, the system displays a warning message similar to this one:

```
SPX join error: Has 17/2/1 -- 18/2/3 (age=0), recv 17/2/1 -- ?/2/3, Transit PE 17 has two cscd-links
```

When this happens, remove the second unit; otherwise, a communication failure may occur.

**FIGURE 22** Unsupported Configuration: PE Unit with Two PE Units Attached at the Same Level Downstream

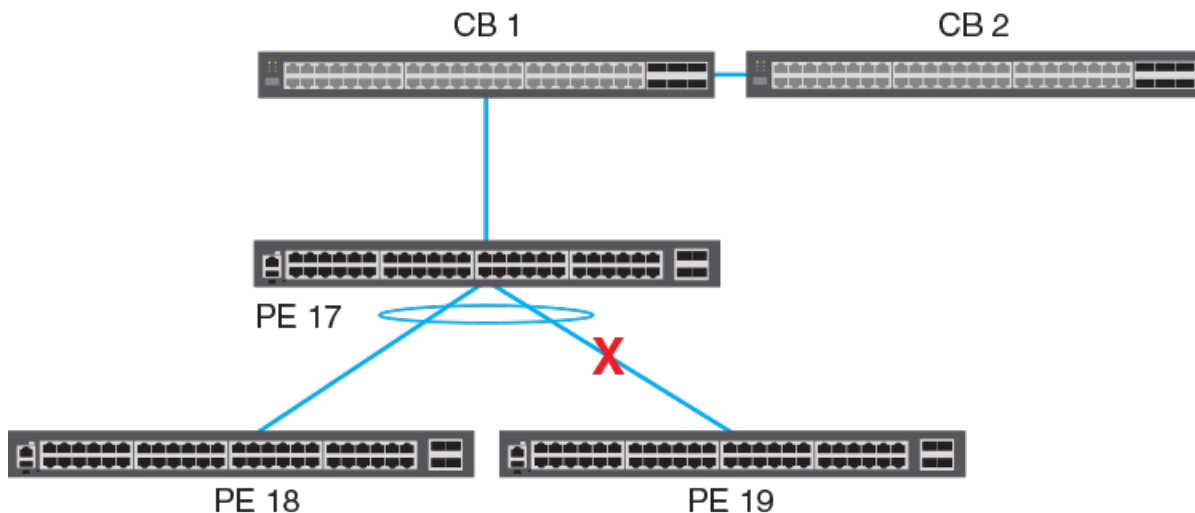

### Unsupported LAG Configurations

A PE unit cannot have two different LAG connections to two units in the CB stack. (That is, a single PE unit cannot form a PE ring.) LAG 2 in the following figure will be blocked (error-disabled) in a Campus Fabric implementation. A single LAG connection from the two CB units to the PE unit is supported as shown in [Supported CB-PE LAG topologies](#) on page 30.

**FIGURE 23** Unsupported Configuration: Two LAGs from the Same PE to Different CB Units

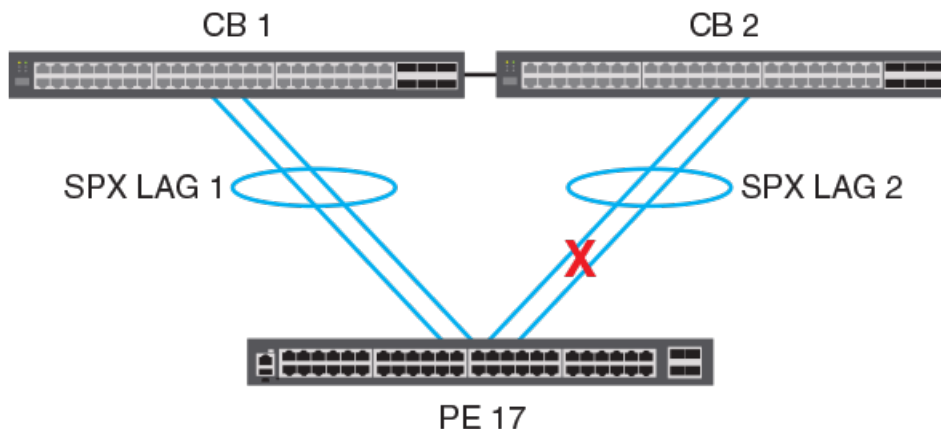

A cascade LAG cannot be configured between the CB and two different PE units. In the following figure, whichever unit, SPX 17 or SPX 18, joins first "wins" the connection. When the remaining PE candidate attempts to join, the system displays a warning message similar to this one:

```
SPX join error: both PE 17 (MAC=1234.5678.ab00) and new PE (MAC=1234.5678.cd00) link to 1/1/20: invalid topology
```

When this happens, remove the second unit; otherwise, a communication failure may occur.

**FIGURE 24** Unsupported Configuration: A Cascade LAG from One CB Unit to Two Different PE Units

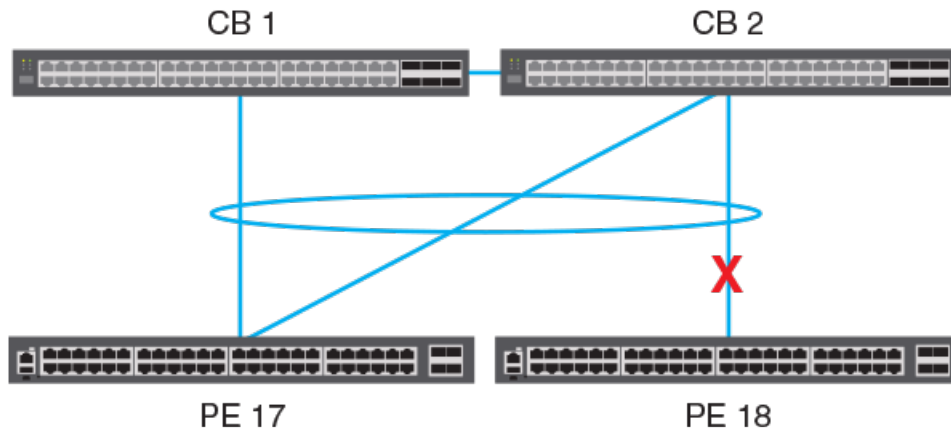

A PE unit cannot be connected to two different units through two different LAGs with overlapping members as shown in the following figure.

**FIGURE 25** Unsupported Configuration: PE Unit with Two SPX LAGs, One Containing the Other

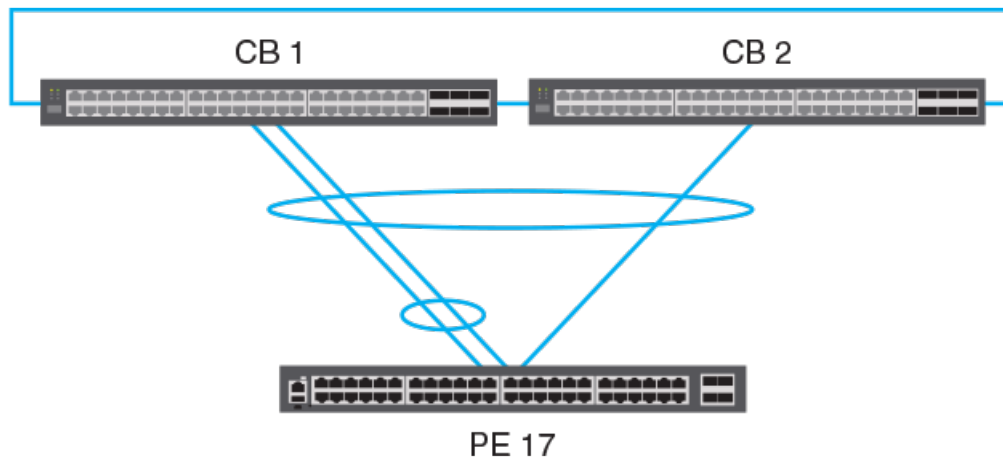

## Topologies Handled by Zero-touch or SPX Interactive-setup

ICX 7150 devices, ICX 7250 devices, ICX 7450 devices, or any combination can be discovered and automatically incorporated into an existing Campus Fabric (SPX) domain when they are present in a valid topology.

Certain topologies can be discovered and automatically configured in an SPX (Campus Fabric) domain by the zero-touch utility. These valid topologies, among others, can also be handled by the SPX interactive-setup utility, which allows the user to determine which units to include in the Campus Fabric domain and what IDs they will be assigned. In addition to the set of valid topologies, the interactive-setup utility handles a broad range of topologies that can be modified by user selections to become valid.

In a valid topology, all discovered units and links can join an existing Campus Fabric domain to form a supported Campus Fabric topology. All new links can be formed automatically into a chain or ring with the zero-touch utility.

For a group of connected new units to be detected by the Campus Fabric domain, the following conditions must be met:

- The new units must be clean units connected through non-base module ports (that is, through modules 2, 3, or 4).

- At least one new unit must have a non-base module port linking to the Campus Fabric domain through SPX probe ports.

SPX probe ports may be any of the following:

- Configured **zero-touch-ports** (configured as described in [Using Zero-touch to Add PE Units](#) on page 53)
- CB SPX ports or SPX LAGs that are not live and that are not attached to existing PE units
- A downstream SPX port or SPX LAG on an edge PE unit (including those formed from either base-module or non-base-module ports)
- All non-base module ports of an edge PE.

SPX probes for new units cannot be sent over the following ports:

- Live SPX ports or SPX LAGs (whether the live ports are on a CB or PE unit)
- Any port that contains configuration.

The following figure depicts valid topologies that can be handled by the zero-touch utility.

**FIGURE 26** Examples of Valid Topologies

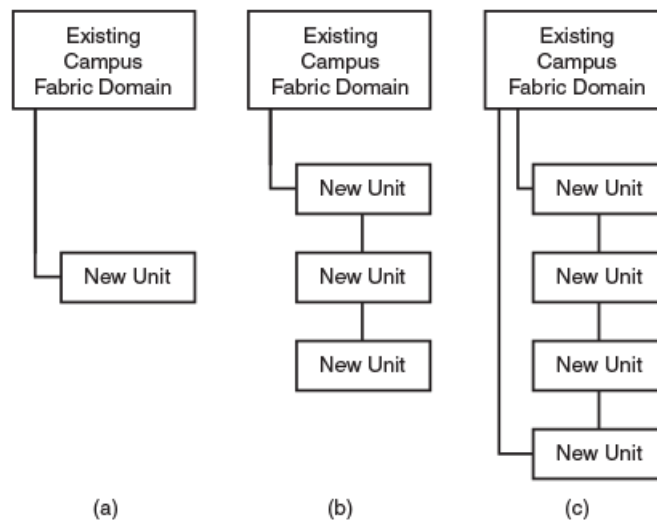

**NOTE**

Figures that depict topology do not necessarily show the maximum number of discoverable PE units in a chain. Up to six potential PE units can be configured in a chain or ring topology.

**NOTE**

Multiple links are not depicted in the previous figure but may be part of valid topologies. When the system detects multiple links between two units, it generates a LAG containing all the links, assuming they are running at the same speed. For more information on LAG splits and merges in Campus Fabric zero-touch and interactive-setup, refer to [SPX LAG Splits and Merges](#) on page 47.

**NOTE**

At times, you may want to protect stand-alone devices from being discovered by Campus Fabric configuration utilities, to prevent them from becoming part of the Campus Fabric domain. For more information, refer to [Protecting a Unit from Being Discovered](#) on page 44.





# Campus Fabric Configuration Overview and Interactive Configuration

---

- Campus Fabric Configuration Overview..... 41
- Protecting a Unit from Being Discovered..... 44
- Zero-touch and SPX Interactive-setup Topology Requirements..... 44
- Zero-touch and SPX Interactive-setup Deployment Considerations..... 50
- Zero-touch Configuration..... 52
- SPX Interactive-setup..... 57

## Campus Fabric Configuration Overview

Before building a Campus Fabric domain, become familiar with related considerations and constraints. Refer to [Planning Considerations for a Campus Fabric Domain](#) on page 23 for more information.

To configure a Campus Fabric domain, the following steps must be completed.

1. Configure and connect two to four ICX 7650, ICX 7750, or ICX 7850 devices in a traditional stack, or configure a standalone ICX 7650, ICX 7750, or ICX 7850.

**NOTE**

Configuring two or more devices in a stack provides redundancy for the control bridge (CB).

2. Enable and configure the stack or standalone device as a CB.
3. Connect ICX 7450, ICX 7250, or ICX 7150 devices to the CB.
4. If you elect to do manual configuration, a fourth step is needed:

Enable and configure the ICX 7450, ICX 7250, or ICX 7150 devices as PE units.

**NOTE**

No matter which configuration method you use, when a PE unit joins the Campus Fabric domain, user data ports don't immediately come up. They are brought up within one minute after all attached PE units have joined in order to avoid interference with the join activity.

**NOTE**

To configure a PE manually, the PE candidate must be running a router image because **spx pe-enable** configuration is not available in the switch image.

**NOTE**

A PE candidate running a switch image can be discovered and added to the Campus Fabric Domain by the zero-touch or the SPX interactive-setup utility; however, because Campus Fabric requires a router image, the new device will initially be in a non-operational state due to an image mismatch. If **tftp-server** is configured and **image-auto-copy** is not disabled, the CB will download a router image to a non-operational PE unit. The PE reloads, joins the Campus Fabric domain, and becomes operational.

**NOTE**

From release 08.0.70, SPX interactive-setup and zero-touch provisioning download images to new units before converting them to PEs if the PEs have different software images. The **tftp-server** command must be configured for image download.

## SPX Interactive-setup

SPX interactive-setup is the recommended method for Campus Fabric configuration. SPX interactive-setup is a tool that can be used even in more complex deployments to convert PE candidates in router or switch mode to PE units. The tool allows you to select PE IDs and configure SPX ports and LAGs. SPX interactive-setup recognizes some invalid SPX topologies that cannot be handled by zero-touch deployment and requests user input to convert them to valid topologies. SPX interactive-setup also allows you to change PE IDs interactively without detaching cables or shutting down units.

## Zero-touch Deployment

Zero-touch deployment converts clean PE candidates in router or switch mode to active PE units without user intervention. In supported topologies, zero-touch detects potential PE units, assigns them IDs, defines SPX ports or LAGs, and reloads them as PE units.

## Manual Configuration

In some situations, you may choose to configure the Campus Fabric domain manually. For example, in manual configuration, there is no requirement that configured ports be non-base module ports. Manual configuration is recommended if connecting candidate PE units involves LAGs or loops. Multiple links between two candidate PEs cause packet looping. You can use manual configuration to create an SPX LAG for multiple links before physically connecting links. A LAG consisting of multiple links is considered a logical link and does not cause packet looping.

For more information on the steps and system processes involved, refer to [Campus Fabric Manual Configuration](#) on page 71.

## Differences in Campus Fabric Configuration Practices

The commands used in Campus Fabric configuration differ from most FastIron commands. You should become familiar with syntax changes. For example, port ranges are handled differently. Configuring ports and trunks also differs in Campus Fabric configuration.

### *Basic Syntax Change in SPX Port Configuration*

SPX ports, like stacking ports, do not use the **ethernet** keyword as part of port configuration. SPX port configuration relies on three-tuple notation as it is used on all current FastIron devices; however, port lists and ranges are used differently.

The **ethernet** keyword continues to be used for configuring ports on standalone devices.

### *Using Port Lists to Specify SPX Ports and Port Ranges*

Campus Fabric configuration introduces a flexible format for representing multiple ports and port ranges in command entry. Valid port lists include any combination of "x/y/z" and "x/y/z to x/y/z" notation. The following examples are all valid port lists in an SPX command:

- 1/2/3 (a single port on CB unit 1)
- 1/2/1 1/2/2 1/1/48 (three separate ports on CB unit 1, which do not have to be presented in ascending order)
- 1/1/40 2/1/1 to 2/1/10 (a single port on CB unit 1, followed by a range of 10 ports on CB unit 2, module 1)
- 2/1/10 to 2/1/15 1/1/30 to 1/1/31 (a range of five ports on CB unit 2, module 1 and a range of two ports on CB unit 1)

### *Differences between SPX LAGs and Stacking Trunks*

In stacking, the secure-setup utility for configuring a stack relies on the presence of two default ports on every stackable unit. The default ports are stacking candidates. The secure-setup utility can send probe packets through these ports even when they are not configured as stacking ports.

Some stackable devices allow you to reconfigure stacking ports or trunks to non-factory settings by first changing the default ports. Even when a user configures only one stacking port or trunk, a stacking unit still requires two default ports.

A stacking trunk cannot be configured unless an underlying stacking port already exists. For example, the command **stack-trunk 1/2/1 to 1/2/3** is only valid when **stack-port 1/2/1** is in place.

Campus Fabric configuration does not use the same secure-setup utility as stacking. The two stacking default ports are not present or required. You can change SPX ports and LAGs on a PE unit without initially defining default ports. Furthermore, an SPX LAG does not require you to first configure a lead stacking port.

SPX LAG (trunk) notation differs from stacking trunk notation in a few fundamental ways:

- Although a stacking trunk requires contiguous ports in the format "x/y/z to x/y/z", an SPX LAG allows noncontiguous ports, with any combination of "x/y/z" and "x/y/z to x/y/z" port notation.
- Stacking trunks contain a range of ports on a single stacking unit on each end. In contrast, ports in a CB SPX LAG can span multiple CB units. (SPX LAGs on PEs must contain ports from only one PE unit, but the ports do not have to be contiguous.)
- The SPX LAG and port commands **spx-lag** and **spx-port** are mutually exclusive in their membership.

### **Port and LAG Reconfiguration Based on Dynamic Entries**

Campus Fabric configuration allows dynamic reconfiguration of ports and LAGs in some cases.

#### **NOTE**

The same rules apply when configuring SPX ports or LAGs on a live system. Configuring ports on a live system may in some cases be less disruptive. Refer to [Configuring SPX Ports and LAGs on a Live System](#) on page 131 for more information.

The following rules govern SPX port and LAG creation:

- If a new SPX port or LAG has any common member with an existing SPX port or LAG, the new entry replaces the existing configuration.
- If a new SPX LAG has common members with multiple SPX port or LAG configurations, an error is returned, and the new configuration is blocked.
- If a new SPX port or LAG does not overlap with existing SPX ports or LAGs, it is added.

The following example creates a LAG with three ports on PE unit 17.

```
ICX7750-26Q Router(config-spx-unit-17)# spx-lag 17/2/2 to 17/2/4
```

The same LAG is changed to a two-port LAG using the following command.

```
ICX7750-26Q Router(config-spx-unit-17)# spx-lag 17/2/2 to 17/2/3
```

The following example configures a single PE port.

```
ICX7750-26Q Router(config-spx-unit-18)# spx-port 18/1/3
```

The same port is reconfigured as part of a LAG using the following command.

```
ICX7750-26Q Router(config-spx-unit-18)# spx-lag 18/1/1 to 18/1/4
```

The following example configures a port and a LAG on PE unit 19.

```
ICX7750-26Q Router(config-spx-unit-19)# spx-port 19/2/1  
ICX7750-26Q Router(config-spx-unit-19)# spx-lag 19/2/3 to 19/2/4
```

With the previous configuration in place, the following entry returns an error.

```
ICX7750-26Q Router(config-spx-unit-19)# spx-lag 19/2/1 to 19/2/3
```

Notice that the new entry requires changes to two existing configurations, a port and a LAG. As a result, the new LAG is blocked.

## Protecting a Unit from Being Discovered

The **spx zero-touch-deny** command can be configured on a traditional stack member or standalone device that is connected to non-SPX ports to prevent the device from being converted to a PE unit accidentally.

Follow these steps to prevent an ICX 7150, ICX 7250, or ICX 7450 device from being discovered and converted by the zero-touch or interactive-setup utility.

### NOTE

Use the **no** form of the command to again make the device available for zero-touch configuration or interactive-setup. The **zero-touch-enable** or the **spx pe-enable** command also removes the **spx zero-touch-deny** setting when entered on the device.

1. Enter global configuration mode.

```
device# configure terminal
```

2. Enter the **spx zero-touch-deny** command.

```
device(config)# spx zero-touch-deny
```

The following example protects an ICX 7450 from being discovered by a CB unit when the zero-touch utility or SPX interactive-setup utility is run.

```
ICX7450-48F Router>
ICX7450-48F Router> enable
No password has been assigned yet...
ICX7450-48F Router# configure terminal
ICX7450-48F Router(config)# spx zero-touch-deny
ICX7450-48F Router(config)#show running-config
Current configuration:
!
ver 08.0.50b1T213
!
stack unit 1
  module 1 icx7450-48f-sf-port-management-module
  module 2 icx7400-xgf-4port-40g-module
  module 4 icx7400-qsfp-lport-40g-module
!
spx zero-touch-deny
!
!
```

## Zero-touch and SPX Interactive-setup Topology Requirements

A Campus Fabric system can discover and automatically configure PE units connected in certain topologies.

The zero-touch and SPX interactive-setup utilities can detect potential SPX connections when clean candidate PE units are connected by non-base module ports (on modules 2, 3, or 4), either directly to the Campus Fabric domain or via other candidate PEs. CB units can be connected to PE candidates through base module or non-base module ports.

From release 08.0.70, zero-touch and SPX interactive-setup are enhanced in the following ways:

- In general, zero-touch and SPX interactive-setup interoperate with future releases. For example, a CB running release 08.0.80 can detect standalone units running release 08.0.70 and vice versa. Note the following exceptions:
  - Releases prior to 08.0.70 are not detected and cannot interoperate with newer releases.

- PE candidates running a pre-08.0.90 image are not detected by a CB running an 08.0.90 or later image due to changes in message type beginning with FastIron release 08.0.90. In this case, upgrade PE candidates to the same image as the CB units before enabling zero-touch provisioning or using the **spx interactive-setup** command.
- As long as **tftp-server** configuration provides correct image location, images can be copied to new units before they are reloaded as PEs so that the PEs run the same image as the CB.
- New links can be detected between a CB and an edge PE or between two edge PEs. Detected links are used to convert one or two PE chains to a ring (in this case, the last PE in a chain is an edge PE). Converting new units to PEs and converting PE chains to rings are fully integrated into a single zero-touch SPX interactive-setup process.

#### NOTE

It is recommended that you make all physical connections before running SPX interactive-setup or zero-touch so that all new units and connections can be detected and processed. Multiple links between two units become one SPX LAG.

#### NOTE

SPX interactive-setup and zero-touch do not detect new links between PEs in the same chain or ring. Once a new unit becomes a PE, new links are not detected, unless the links are on an edge PE.

Valid and invalid topologies for zero-touch and SPX interactive-setup utilities are described in [Campus Fabric Topology Overview](#) on page 28. The utility handles only valid topologies. When the zero-touch utility can detect an invalid topology, it issues a warning.

The SPX interactive-setup utility handles valid topologies and allows user intervention to select desired units or change PE IDs. The interactive-setup utility also handles many invalid topologies when users can select units to create a valid topology. Where possible, interactive-setup presents the discovered topology for user selection. When the system detects a topology it cannot present, it generates a warning.

#### NOTE

The manual Campus Fabric configuration process does not require non-base module ports. Manual configuration is recommended if connecting candidate PE units involves LAGs or loops. Multiple links between two candidate PEs cause packet looping. You can use manual configuration to create an SPX LAG for multiple links before physically connecting links. A LAG consisting of multiple links is considered a logical link and does not cause packet looping.

## Zero-touch and SPX Interactive-setup for PE Units with Live Traffic

Zero-touch and SPX interactive-setup have enhancements to harden the discovery process as of FastIron release 8.0.61. Previously, if live clients were connected to switches waiting to be converted to PE units, there was a chance of loops. Now, loop packets are dropped until discovery is complete. This greatly enhances the reliability of discovering all PE candidates and links under severe situations. The loops are removed after zero-touch or SPX interactive-setup changes multiple inter-switch links between two units into a LAG.

If your system has no live traffic, you can connect new units the way you want without being concerned about creating loops. If your system has clients carrying live traffic, there are going to be temporary loops. As long as you allow zero-touch or SPX interactive-setup to discover all units and links, and change discovered units to PEs to generate appropriate running-configuration, the loops are handled and should resolve automatically.

## Invalid Topologies that Can Be Handled by SPX Interactive-setup

The following figure depicts some invalid topologies that can be handled by SPX interactive-setup. These topologies include new units that form a chain or ring of up to six units and that have one or two uplinks to the existing Campus Fabric domain.

**FIGURE 27** Invalid Topologies Handled by SPX Interactive-setup

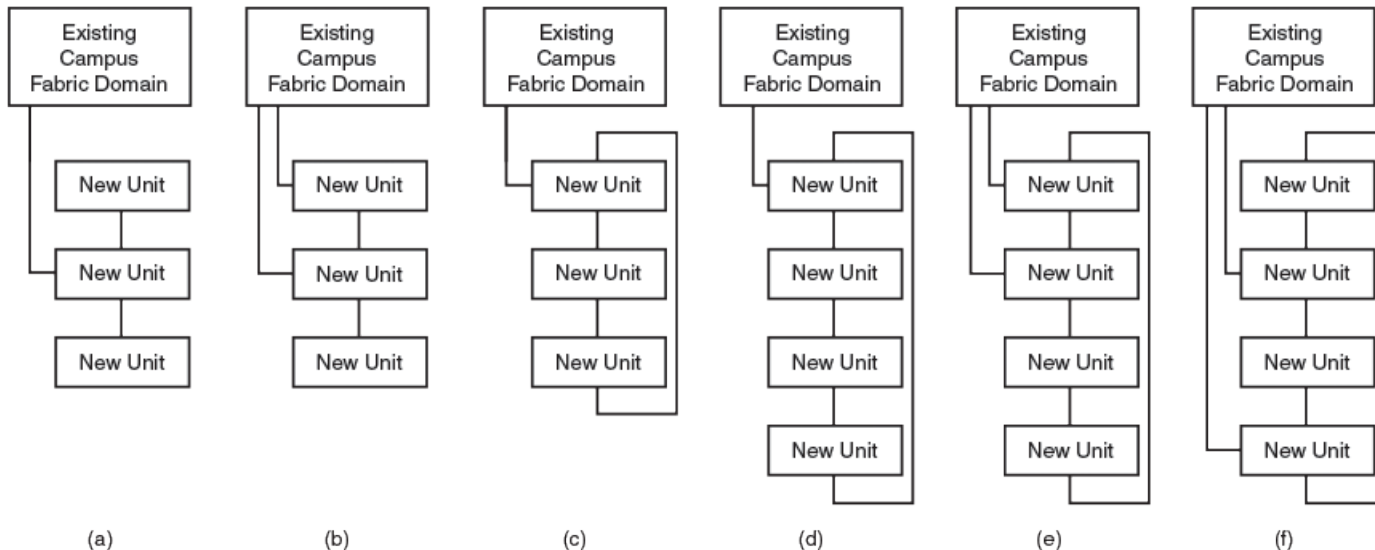

### Special Cases Where a Link Can Be Removed to Select All New Units

You can select units to include in a Campus Fabric domain as part of SPX interactive-setup. When you select units, all their interconnections are selected as SPX ports or SPX LAGs. To prevent you from creating an invalid Campus Fabric topology, the interactive-setup utility does not generally allow you to remove links. In certain cases, however, you are allowed to remove a link to present all potential units in a valid topology.

- Case 1—A ring of new units has one uplink to the CB or to another PE unit.
- Case 2—A ring of new units has two uplinks to the CB or other PE units, and the two uplinks are on two new neighbor units.

**Case 1.** The following example shows a ring of potential units connected through a single uplink to the Campus Fabric domain.

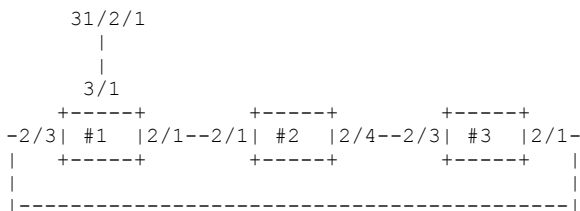

**FIGURE 28** Case 1: Ring of Potential PEs with One Direct Connection to the CB



To form a valid topology, the user has the option to remove the link between units 1 and 2 or the link between units 1 and 3.

FIGURE 29 Case 1: Resolution



**Case 2.** The following example shows a ring of new units with two uplinks through neighboring units 1 and 2.

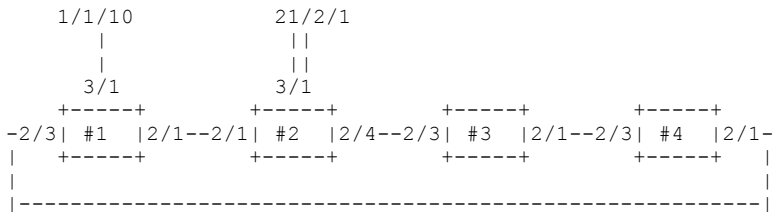
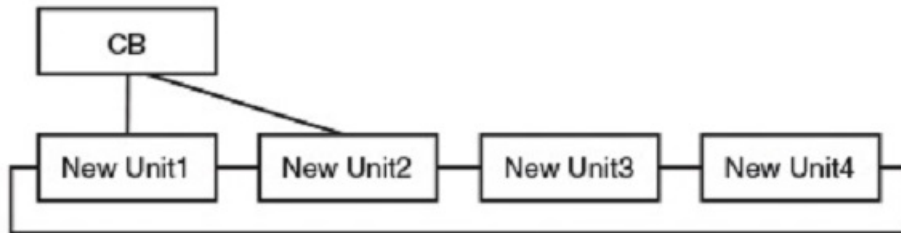
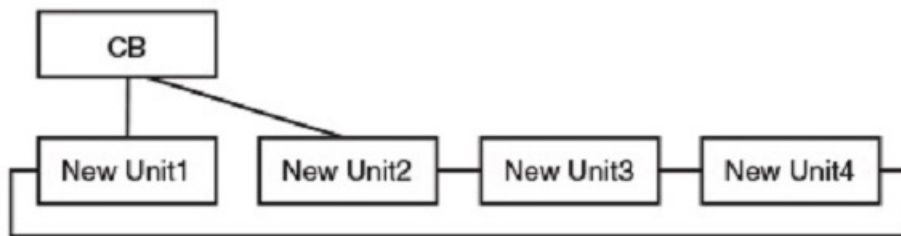

FIGURE 30 Case 2: Ring with Two Connections to the CB through Neighboring Units



The user has the option to remove the link between units 1 and 2 to form a valid topology.

FIGURE 31 Case 2: Resolution



## SPX LAG Splits and Merges

Both the zero-touch utility and the SPX interactive-setup utility can split or merge CB and PE SPX ports and LAGs to match discovered new topology. When SPX LAGs split or merge, some ports are disabled. The zero-touch and SPX interactive-setup utilities re-enable ports that become SPX ports and SPX LAGs. Ports that become data ports remain disabled.

**NOTE**

Data ports can be re-enabled at the interface configuration level using the **no disable** command. For example:

```
device# configure terminal
device(config)# interface 17/2/1
device(config-17/2/1)# no disable
```

**Ports of Different Speeds**

All ports in a LAG must have the same speed. When the zero-touch utility or the interactive-setup utility encounters ports with different speeds, it assigns them to different SPX ports or LAGs.

Here are some examples of how the system forms SPX connections from ports running at different speeds.

**FIGURE 32** Single PE with Multiple 40-Gbps Links and One 10-Gbps Link

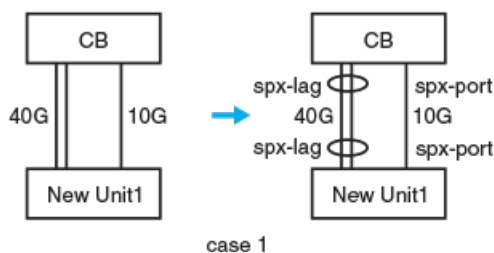

In the previous example, a ring of only one PE is formed because all links are classified in two directions due to their different speeds. Because a single PE ring is an invalid topology, the system prints and logs a warning message. The new unit is not converted to a PE.

**FIGURE 33** New PE Chain with Multiple 40-Gbps Links and Single 10-Gbps Link

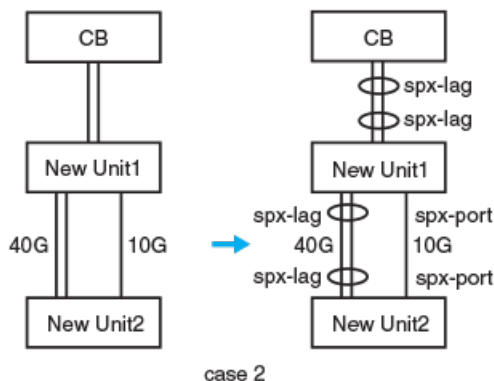

The previous figure forms an invalid topology. The zero-touch utility issues a warning when the topology is formed. The SPX interactive utility allows you to remove the 10-Gbps links or the 40-Gbps links. The two new units form a ring with one uplink. This is an example of Case 1 in [Special Cases Where a Link Can Be Removed to Select All New Units](#) on page 46.

**Detecting New Links and Converting PE Chains to Rings**

From release 08.0.70, SPX interactive-setup and zero-touch provisioning can detect links between a CB unit and an edge PE or between two edge PE units. When these links are detected, the associated PE chain or, if present, both associated PE chains are converted into a ring.



**NOTE**

SPX interactive-setup and zero-touch provisioning do not detect new links between existing PEs in the same chain or ring. As a result, neither utility can expand an existing SPX LAG. Use the **multi-spx-lag** command to change SPX LAGs on a live link.

**NOTE**

To form an SPX LAG between two PE chains, connect multiple links between two units before running SPX interactive-setup or before enabling zero-touch provisioning. Either utility detects all links and generates an SPX LAG containing the ports. Once a chain is converted to a ring, neither SPX interactive-setup or zero-touch provisioning can detect any new link between units of a PE chain or ring.

The capability to convert one or two PE chains to a ring is fully integrated into both SPX interactive-setup and zero-touch provisioning. Both utilities can discover new units and/or convert PE chains in a single process. If SPX interactive-setup detects both possibilities, the interactive process handles PE chain-to-ring conversion before handling new units.

When SPX interactive-setup or zero-touch provisioning detects links between an CB and an edge PE or between two edge PEs and converts PE chains to a ring, the system generates any needed SPX port or SPX LAG configuration for the ring. No reload is required; however, you should execute the **write memory** command to save the new SPX port or SPX LAG configuration.

A link can be detected only when at least one end sends probes. The following ports transmit probe packets:

1. CB SPX ports and CB SPX LAGs that have no live PE link
2. CB ports configured as zero-touch ports
3. Edge PE ports on non-base modules 2, 3, or 4, excluding upstream SPX ports or SPX LAGs and any ports with configuration. In this case, an edge PE port is always the last unit of a chain.

As an example, if a base-module port on an edge PE connects to a CB zero-touch port, the link can be detected because, although PE base-module ports do not send probes, the CB zero-touch port at the other end of the link does.

If a link connects to a CB port, the port must be an SPX port, part of an SPX LAG, or a zero-touch port. Otherwise, the system prints a warning message to remove the link. A PE port detected on the link can be any port as long as it does not have configuration.

All links between two units are assigned to a single SPX LAG. You should complete all physical connections before running SPX interactive-setup or enabling zero-touch provisioning because once one or two PE chains form a ring, the ring can no longer send the probes used by the two utilities to detect new units or links.

The following figure shows the two general ways that PE chains are converted to rings. A dashed line indicates a new link, which may consist of one or multiple physical links.

**FIGURE 34** Two Types of Automatic PE Chain-to-ring Conversion

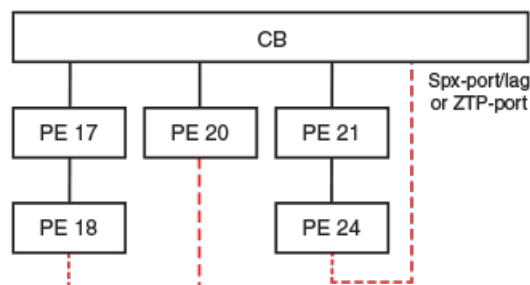

**Invalid PE Rings**

The SPX system runs many sanity checks to confirm that the connections are valid. When an invalid connection is discovered, the system prints a warning message that describes the invalid connection and requests that the connection be removed.

The following figure illustrates several invalid connections that cannot form a PE ring.

**FIGURE 35** Invalid PE Configurations that Cannot Automatically Form Rings

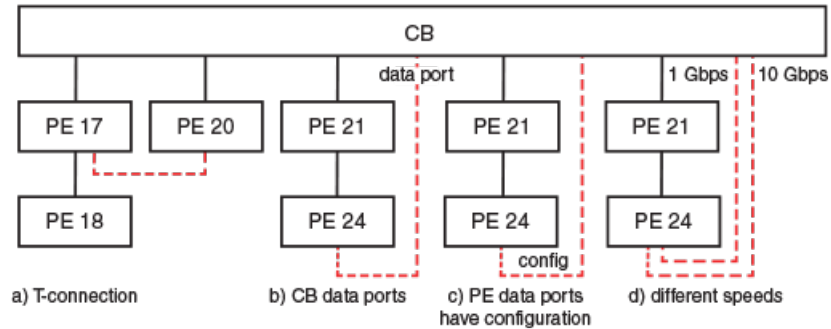

Label	Reason PE Ring Cannot Be Formed
a	T-connections are invalid.
b	The CB port is not an SPX port, SPX LAG member, or zero-touch-port.
c	The PE data port has configuration.
d	Links of different speeds cannot be automatically merged into an SPX LAG.

## Zero-touch and SPX Interactive-setup Deployment Considerations

SPX interactive-setup is a superset of zero-touch provisioning. Both Campus Fabric provisioning methods use the same discovery procedures, algorithms, and configured probing ports. In fact, zero-touch provisioning generates the same results that SPX interactive-setup would if you accepted all default values presented by pressing **Enter** or **Y** when prompted.

RUCKUS recommends SPX interactive-setup over zero-touch provisioning for the following reasons:

- SPX interactive-setup triggers a topology discovery as soon as you launch the utility. In contrast, zero-touch does topology discovery every 3 minutes in background (although zero-touch discovery is triggered within one minute when the probing ports first become active).

**NOTE**

You should connect all physical links before running SPX interactive-setup or enabling zero-touch provisioning so that all new units and links are discovered in one process. Furthermore, although you have control over when SPX interactive-setup runs, if zero-touch provisioning is enabled, it could be triggered in background before you have finished all the physical connections.

**NOTE**

If you use zero-touch provisioning, you should remove **zero-touch-enable** configuration after SPX system construction is complete. Otherwise, the system continues to send periodic zero-touch probes in background. While the continued probes are harmless, they waste CPU time and generate unnecessary packets.

- SPX interactive-setup displays the discovered topology.
- SPX interactive-setup includes options that allow you to select units or IDs.
- SPX interactive-setup also includes options that allow you to select units or links to transform an invalid topology into a valid topology.

## Zero-touch and SPX Interactive-setup Deployment Limitation

Zero-touch provisioning and SPX interactive-setup cannot detect a standalone unit that is connected behind a PE that has not joined the SPX system. Consider the following illustration. On the left is the original PE chain topology. Assume that you are replacing PE units 2, 3, and 5 with new units. Zero-touch and SPX interactive-setup can detect new units 2 and 3 (shown in the new topology on the right as NU 2 and NU 3). Neither utility can detect the new unit NU 5 because it is separated from the SPX system by PE unit 4, which has not joined the SPX system yet. PE unit 4 does not rejoin the SPX system until new units NU 2 and NU 3 have joined the system as PE units. To detect and convert NU 5 to a PE, you can initiate SPX interactive-setup again. If zero-touch provisioning is running, it will discover NU 5 the next time it is triggered (after three minutes).

**FIGURE 36** Undetected Standalone Separated from Active PE Chain

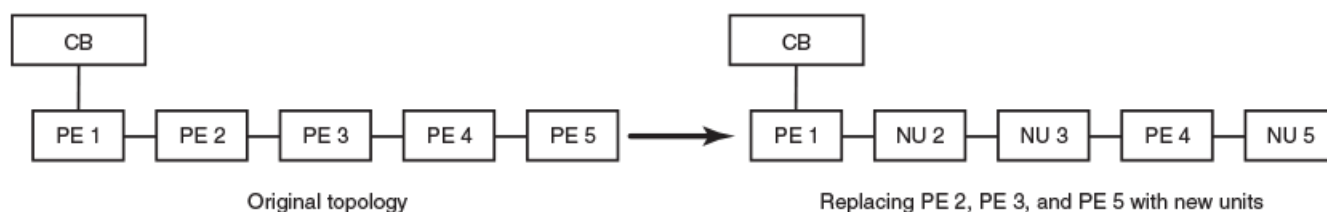

## Zero-touch and SPX Interactive-setup Deployment Recommendations

Keep the following points in mind when configuring the Campus Fabric domain with the zero-touch or SPX interactive-setup utility.

- Before LAGs are formed, individual links may cause loops, especially if CB or PE units are connected to clients running any control protocols.
- Multiple links between any two units cause loops until they are converted to an SPX LAG. SPX ports and SPX LAGs are recommended to avoid loops.
- Loops cause high traffic in the looped ports and may cause high CPU if looped packets are trapped to the CPU.
- The zero-touch utility does not run if the CPU level is greater than 96%. Instead, the utility issues a warning that suggests using the SPX interactive-setup utility.
- Loops should be resolved once the zero-touch or SPX interactive-setup utility has converted multiple links between any two units to SPX LAGs.
- As a best practice, you should remove **zero-touch-ports** configuration once PE discovery is complete. You should also disable **zero-touch-enable**.
- After PE discovery is complete and you have removed **zero-touch-enable** configuration, you can always run SPX interactive-setup to make changes to the existing system, for example, to move PE units or change PE IDs.
- Do not connect hosts or access points to PE candidates until zero-touch provisioning is complete.
- We recommend the SPX interactive-setup utility in a live production environment with connected hosts and access points.
- Zero-touch configuration works for PE candidates that have no configuration.
- Once new units have been connected to the Campus Fabric domain, check for loops by entering the **clear statistics** and then the **show statistics brief** commands on the CB. The packet counts displayed in command output should be low. If packet counts are high, that indicates loops in the system. The SPX interactive-setup utility can resolve all loops.

Manual configuration can always be used instead of zero-touch provisioning or SPX interactive-setup for greater control over the discovery process and to avoid loops and high CPU. Manual configuration requires these steps:

1. Configure correct SPX ports or LAGs on the CB and on new PE candidates.

2. Configure and reload new units to convert them to PEs. For more information, refer to [Manually Enabling and Configuring PE Units](#) on page 74.
3. Physically connect the links.

**NOTE**

Zero-touch and SPX interactive-setup have enhancements to harden the discovery process as of FastIron release 8.0.61. Previously, if live clients were connected to switches waiting to be converted to PE units, there was a chance of loops. Now, loop packets are dropped until discovery is complete. This enhances the reliability of discovering all PE candidates and links under severe situations. The loops are removed after zero-touch or SPX interactive-setup changes multiple inter-switch links between two units into a LAG. If your system has no live traffic, you can connect new units the way you want without being concerned about creating loops. If your system has clients carrying live traffic, there are going to be temporary loops. As long as you allow zero-touch or SPX interactive-setup to discover all units and links, and change discovered units to PEs to generate appropriate running-configuration, the loops are handled and should resolve automatically.

## Zero-touch Configuration

The zero-touch utility can be used to discover and deploy new PE units without user intervention when the new units are presented in a valid configuration.

Use the **zero-touch-enable** command available under **spx configure** to enable the zero-touch utility. To identify new PE candidates, zero-touch probe packets are transmitted over CB SPX ports, SPX LAGs, the non-base-module ports of edge PE units, and user-configured zero-touch candidate ports.

**NOTE**

The first time you enable zero-touch configuration, the system sends a zero-touch probe within 60 seconds. If a CB port comes up or goes down, or if a port specified in the **zero-touch-ports** configuration or a CB SPX port or LAG with no connection becomes active, a zero-touch probe is also triggered within a minute. Otherwise, a probe is sent every three minutes.

**NOTE**

If a port is already up, adding it as an SPX port, adding it to an SPX LAG, or configuring it as a zero-touch port does not trigger the next zero-touch probe within 60 seconds.

**NOTE**

RUCKUS recommends disabling zero-touch provisioning once PE discovery is complete.

When PE candidates are discovered in a valid topology, zero-touch candidate ports are converted to CB SPX ports or CB SPX LAGs so that the new PE units can join the Campus Fabric domain. The system displays a message about the new CB SPX ports and LAGs and prompts the user to execute the **write memory** command to save the new domain configuration.

You must configure the zero-touch candidate ports using the **zero-touch-ports** command before probe packets can be transmitted over them. Zero-touch ports can only be used to discover new PE units, not to modify existing SPX ports or LAGs. For information on configuring zero-touch-ports, refer to [Using Zero-touch to Add PE Units](#) on page 53.

## Topologies that Support Zero-touch Configuration

The zero-touch utility works only for supported topologies. When the utility encounters an invalid topology, it displays a warning message, in which case you may opt to run the interactive-setup utility instead. The interactive-setup utility can be used for a broader range of topologies and allows the user to select PE candidates interactively for inclusion in the Campus Fabric domain. For more information on the interactive-setup utility refer to [SPX Interactive-setup](#) on page 57.

The zero-touch utility can discover and automatically configure clean ICX 7150, ICX 7250, or ICX 7450 units as new PEs when they occur in one of the topologies covered in [Topologies Handled by Zero-touch or SPX Interactive-setup](#) on page 38.

## Additional Zero-touch Considerations

- The system checks the ports in any **zero-touch-ports** range you configure and allows the configuration only if all ports in the range are valid. None of the ports in the range may contain configuration.
- Once new PEs have been detected and added, the **zero-touch-ports** configuration should be removed to free the ports for other uses.
- The zero-touch utility automatically assigns PE IDs based on **spx pe-id** configuration or internal algorithms.
- The zero-touch utility automatically generates SPX ports or LAGs for the PE units.
- The end unit in a chain of new PE units is assigned only one SPX port or LAG.

## Using Zero-touch to Add PE Units

Use the zero-touch utility to add PE units to the Campus Fabric domain without having to make user selections.

Follow these steps to configure zero-touch deployment.

### NOTE

The first time you enable zero-touch configuration, the system sends a zero-touch probe within 60 seconds. If a CB port comes up, or if a port specified in the **zero-touch-ports** configuration or a CB SPX port or LAG with no connection becomes active, a zero-touch probe is also triggered within a minute. Otherwise, a probe is sent every three minutes.

### NOTE

If a port is already up, adding it as an SPX port, adding it to an SPX LAG, or configuring it as a zero-touch port does not trigger the next zero-touch probe within 60 seconds.

### NOTE

RUCKUS recommends disabling zero-touch provisioning once PE discovery is complete.

1. If necessary, create clean units. On the local console of each ICX 7150, ICX 7250, or ICX 7450 unit, enter the following.

```
Device# erase startup-config
!
!
Device# reload
!
!
```

When the system asks whether to reload without saving the configuration enter **y**.

2. Attach clean ICX 7150, ICX 7250, or ICX 7450 units to the existing Campus Fabric domain as candidate PEs. The new units must have no startup\_config flash.

### NOTE

The example shows how to enable a standalone ICX 7750 unit as the CB before adding PE units. A standalone ICX 7650, ICX 7750, or ICX 7850 or a stack of ICX 7650, ICX 7750, or ICX 7850 units acting as the CB would add PE units in the same way. The running configuration may also show that the CB is already enabled.

3. Use the **show running-config** command to verify that the CB is enabled and to check SPX port and LAG configurations.

```
ICX7750-48F Router# show running-config
Current configuration:
!
ver 08.0.50b1T203
!
stack unit 1
  module 1 icx7750-48-xgf-port-management-module
  module 2 icx7750-qsfp-6port-qsfp-240g-module
  module 3 icx7750-6q-6port-qsfp-240g-module
!
!

no inline power non-pd-detection enable
ip ssl min-version tls_1_1
!
!

interface management 1
!
!

end
```

In this example, the **show running-config** command indicates that the CB is not enabled on the ICX 7750 standalone unit.

4. If necessary, in global configuration mode, enter the **spx cb-enable** command to enable the CB. If spanning tree is present, you are prompted to confirm the reload. Type **y** when prompted.

```
ICX7750-48F Router# configure terminal
ICX7750-48F Router(config)# spx cb-enable
System is now in 802.lbr control bridge (CB) mode.

ICX7750-48F Router# configure terminal
ICX7750-48F Router(config)# spx cb-enable
Spanning Tree Protocols require a reload. Are you sure? (enter 'y' or 'n'): y
System is now in 802.lbr control bridge (CB) mode.

1 Saved config, reloading the system...
!
!
```

In the first example, the CB is enabled without a system reload. In the second example, the CB is enabled after a reload because Spanning Tree configuration is present.

5. Enter SPX CB configuration mode.

```
ICX7750-48F Router(config)# spx cb-config
```

6. If necessary, configure a CB SPX port or LAG that connects to the PE candidates.

```
ICX7750-48F Router(config-spx-cb)# spx-port 1/1/2
```

The example configures SPX port 1/1/2.

#### NOTE

The sample SPX port is included here only for informational purposes and does not appear in the actual system configuration.

7. If necessary, configure the ports or range of ports over which zero-touch probe packets will be sent. (These are unconfigured ports, not CB SPX ports or LAGs, over which PE candidates should be detected.)

```
ICX7750-48F Router(config-spx-cb)# zero-touch-ports 1/1/3 1/1/16
```

In the example, probe packets will be sent over ports 1/1/3 and 1/1/16 in addition to any configured SPX ports and SPX LAGs.

8. Enable the zero-touch utility.

```
ICX7750-48F Router(config-spx-cb)# zero-touch-enable
ICX7750-48F Router(config-spx-cb)# end
Send reload to chain0: #2 CC4E.24DC.E9CE ID=18, D0: 2/3, D1: 2/5 to 2/6 2/8
#1 CC4E.24DC.F166 ID=17, D0: 2/5 to 2/6 2/8, D1: 2/4

T=12m23.5: Add spx-port 1/1/16 for a discovered unit to join
T=12m23.6: Add spx-port 1/1/3 for a discovered unit to join
PE-port=17/2/4 CB-port=1/1/16
Sica Unit id:17, PoD License Capacity:8
PE-port=18/2/3 CB-port=1/1/3
Sica Unit id:18, PoD License Capacity:8
Stack unit 18 Power supply 1 is up
Stack unit 18 Power supply 2 is down
Stack unit 17 Power supply 1 is up
Stack unit 17 Power supply 2 is down
```

The example enables the zero-touch utility. A system reload of new units follows. CB SPX ports 1/1/16 and 1/1/3 are added because a PE candidate has been discovered over the zero-touch-ports. New PE unit 17 is connected through PE port 17/2/4, and new PE unit 18 is connected through port 18/2/3.

**NOTE**

The **zero-touch-enable** command disables the interactive-setup utility if it has been enabled.

The CB notifies you of PE candidates discovered, assigns PE IDs, and displays the new configuration including auto-generated SPX connections.

**NOTE**

If the CB encounters an unsupported topology, it displays a warning message.

**NOTE**

If you do not want to accept the PE ID or the new configuration, or if the zero-touch utility issued a warning and could not handle the topology, you can attempt an interactive setup instead. Refer to [SPX Interactive-setup](#) on page 57 for more information.

9. Enter the **write memory** command to save the configuration change.

```
ICX7750-48F Router# write memory
```

10. Confirm the configuration with the **show spx** command.

```
ICX7750-48F Router# show spx
T=20m3.1: alone: standalone, D: dynamic cfg, S: static
ID  Type      Role      Mac Address  Pri State  Comment
1   S ICX7750-48XGF alone      cc4e.24d2.2c00  0 local  Ready
17  D ICX7250-24  spx-pe    cc4e.24dc.f166 N/A remote Ready
18  D ICX7250-24  spx-pe    cc4e.24dc.e9ce N/A remote Ready

+----+
2/1| 1 |2/4
+----+
      +-----+      +-----+
1/1/3--2/3| 18 |2/5==2/5| 17 |2/4--1/1/16
      +-----+      +-----+
```

The example displays the Campus Fabric domain configuration. The standalone CB has added two ICX 7250 PE units, 17 and 18. They are configured in a ring and are connected to the CB through CB SPX ports 1/1/3 (at PE port 18/2/3) and 1/1/16 (at PE port 17/2/4).

## Campus Fabric Configuration Overview and Interactive Configuration

### Zero-touch Configuration

The following example configures a standalone as a CB, establishes two zero-touch ports, enables the zero-touch utility, and adds two PE units to form a Campus Fabric domain.

```
ICX7750-48F Router> enable
No password has been assigned yet...
ICX7750-48F Router# show running-config
Current configuration:
!
ver 08.0.50b1T203
!
stack unit 1
  module 1 icx7750-48-xgf-port-management-module
  module 2 icx7750-qsfp-6port-qsfp-240g-module
  module 3 icx7750-6q-6port-qsfp-240g-module
!
!
no inline power non-pd-detection enable
ip ssl min-version tls_1_1
!
!
interface management 1
!
!
end
ICX7750-48F Router# configure terminal
ICX7750-48F Router(config)# spx cb-enable
System is now in 802.1br control bridge (CB) mode.
ICX7750-48F Router(config)# spx cb-config
ICX7750-48F Router(config-spx-cb)# zero-touch-ports 1/1/3 1/1/16
ICX7750-48F Router(config-spx-cb)# zero-touch-enable
ICX7750-48F Router(config-spx-cb)# end
Send reload to chain0: #2 CC4E.24DC.E9CE ID=18, D0: 2/3, D1: 2/5 to 2/6 2/8
#1 CC4E.24DC.F166 ID=17, D0: 2/5 to 2/6 2/8, D1: 2/4

T=12m23.5: Add spx-port 1/1/16 for a discovered unit to join
T=12m23.6: Add spx-port 1/1/3 for a discovered unit to join
PE-port=17/2/4 CB-port=1/1/16
Sica Unit id:17, PoD License Capacity:8
PE-port=18/2/3 CB-port=1/1/3
Sica Unit id:18, PoD License Capacity:8
Stack unit 18 Power supply 1 is up
Stack unit 18 Power supply 2 is down
Stack unit 17 Power supply 1 is up
Stack unit 17 Power supply 2 is down

ICX7750-48F Router# show spx
T=20m3.1: alone: standalone, D: dynamic cfg, S: static
ID  Type      Role      Mac Address  Pri State  Comment
1   S ICX7750-48XGF alone    cc4e.24d2.2c00  0 local  Ready
17  D ICX7250-24  spx-pe    cc4e.24dc.f166 N/A remote Ready
18  D ICX7250-24  spx-pe    cc4e.24dc.e9ce N/A remote Ready

      +----+
      2/1| 1 |2/4
      +----+
          +----+      +----+
      1/1/3--2/3| 18 |2/5==2/5| 17 |2/4--1/1/16
          +----+      +----+
ICX7750-48F Router# write memory
```



## SPX Interactive-setup

SPX interactive-setup is an interactive tool that guides the user through Campus Fabric configuration. It can be used to configure a broader range of topologies than the zero-touch utility.

### NOTE

For more information on the topologies that the SPX interactive-setup utility handles, refer to [Zero-touch and SPX Interactive-setup Topology Requirements](#) on page 44.

The SPX interactive-setup utility handles a variety of SPX topologies by prompting the user to make necessary configuration selections to render the topology valid. You can use interactive-setup to configure a new Campus Fabric domain or to add units to an existing domain. The utility can also help you change PE IDs or convert an existing stack of ICX 7150, ICX 7250, or ICX 7450 units to a PE chain or ring.

## Changing PE IDs with SPX Interactive-setup

SPX interactive-setup makes changing PE IDs simpler.

The procedure assumes that SPX has been enabled as described in this guide.

Follow these steps to change assigned PE IDs in a Campus Fabric domain with SPX interactive-setup.

#### NOTE

The new PE ID can be any ID including an existing or provisional PE ID. The exception is an ID that causes a module mismatch.

1. Use the **show running-config** command to verify that the CB is enabled and to check SPX port and LAG configurations.

```
ICX7750-48F Router(config)# show running-config
Current configuration:
!
ver 08.0.50b1T203
!
stack unit 1
  module 1 icx7750-48-xgf-port-management-module
  module 2 icx7750-qsfp-6port-qsfp-240g-module
  module 3 icx7750-6q-6port-qsfp-240g-module
spx unit 17
  module 1 icx7250-24-port-management-module
  module 2 icx7250-sfp-plus-8port-80g-module
  spx-port 17/2/4
  spx-lag 17/2/5 to 17/2/6 17/2/8
spx unit 18
  module 1 icx7250-24-port-management-module
  module 2 icx7250-sfp-plus-8port-80g-module
  spx-port 18/2/3
  spx-lag 18/2/5 to 18/2/6 18/2/8
!
!
spx cb-enable
spx cb-configure
  zero-touch-enable
  spx-port 1/1/3
  spx-port 1/1/16
  zero-touch-ports 1/1/3 to 1/1/16
  pe-id 1/1/3 18 17 1/1/16
!
!
no inline power non-pd-detection enable
ip ssl min-version tls_1_1
!
!
interface management 1
!
!
end
```

In this example, the **show running-config** command indicates that the CB is already enabled. The zero-touch utility is also enabled and must be disabled. Two CB SPX ports (1/1/3 and 1/1/16) are configured, and a range of ports are identified by the **zero-touch-ports** configuration to detect new PE candidates. Two PEs, 17 and 18, are attached to the CB (a standalone ICX 7750).

2. If necessary, disable the zero-touch utility.

```
ICX7750-48F Router(config-spx-cb)# no zero-touch-enable      <-- You cannot run spx interactive-
                                                             setup when zero-touch
                                                             is enabled.
ICX7750-48F Router(config-spx-cb)# end
```

In the example, the zero-touch utility is disabled as a precursor to enabling interactive-setup.

3. In Privileged EXEC mode, enable the spx interactive-setup utility.

```
ICX7750-48F Router# spx interactive-setup
You can abort spx interactive-setup at any stage by <ctrl-c>
0: quit
1: change PE IDs
2: discover and convert new units (no startup-config flash) to PEs
3: discover and convert existing/new standalone units to PEs
2&3 can also find new links and convert chain(s) to ring.
```

The example shows the options available when you start the interactive-setup utility.

4. When prompted, type "1" to change PE IDs.

```
Please type your selection: 1
+-----+ +-----+
1/1/3--2/3| 18 |2/5==2/5| 17 |2/4--1/1/16
+-----+ +-----+
```

5. When prompted, type the new ID for each PE unit. After you complete your entry, type **done**. If you do not want to change the ID of a particular PE, press the Enter key. At the end of the PE list, you are prompted to confirm or cancel your entries.

**NOTE**

A PE ID can be changed to any legitimate ID, even if it is used by an existing PE. For example, you can swap two IDs. There are a few exceptions:

- The module configuration of the new ID must either be empty or match the PE.
- SPX port or LAG configuration, including speed configuration, must match.

If you try to change a PE ID using an existing ID or provisional PE ID with a module mismatch, the ID selection is blocked, and SPX interactive-setup prints a warning similar to the following message.

```
Error! PE21 --> 51 requires same modules or no PE51 configuration.
Allowed IDs: 18,21,26-29,33-39,42-49,52-56
```

If you select an existing or provisional ID that would result in an SPX port or SPX LAG configuration mismatch, the system blocks the configuration and displays a warning similar to the following message.

```
Error! PE21 --> 23 requires same spx-port/lag or no PE23 configuration.
Allowed IDs: 18,21,26-29,33-39,42-49,52-56
```

If you select an existing or provisional ID that would result in an SPX port or SPX LAG speed mismatch, the system blocks the configuration and displays a warning similar to the following message.

```
Error! PE21 --> 32: Port 21/2/2 and 32/2/2 have different speed configuration.
Allowed IDs: 18,21,26-29,33-39,42-49,52-56
```

**NOTE**

After a PE is re-numbered, the old configuration still exists if it is a static unit. The system does not convert the old configuration to the new IDs. For example, if PE 20 changes its ID to 30, the system does not move interface 20/1/1 configuration to interface 30/1/1.

**NOTE**

You can type **n** to cancel. If you need to cancel later, type **Cntrl-C** at any time.

6. Type **y** to confirm your changes.

You do not need to physically detach or un-configure any unit. The system temporarily disables any SPX ports or LAGs necessary to detach the affected PE units. After a few seconds, the ports are re-enabled, allowing the PEs to join with new PE IDs.

```
Type "done" to finish, or a new ID for PE 18 (default 18): 23
Type "done" to finish, or a new ID for PE 17 (default 17): 24
Change IDs: 18->23, 17->24,
Do you want to proceed? (enter 'y' or 'n'): y
T=14m43.4: Sending new IDs to PE(s) 17-18...
power down ports to detach PEs: 1/1/3 1/1/16
power up ports: 1/1/3 1/1/16.
Affected PEs will join with new IDs.
Exit spx interactive-setup, reason: done ID changes
Sica Unit id:24, PoD License Capacity:8
Stack unit 24 Power supply 1 is up
Stack unit 24 Power supply 2 is down
Sica Unit id:23, PoD License Capacity:8
Stack unit 23 Power supply 1 is up
Stack unit 23 Power supply 2 is down
sh spx
T=17m13.2: alone: standalone, D: dynamic cfg, S: static
ID  Type      Role      Mac Address  Pri State  Comment
1   S ICX7750-48XGF alone      cc4e.24d2.2c00  0 local  Ready
23  D ICX7250-24  spx-pe    cc4e.24dc.e9ce N/A remote Ready
24  D ICX7250-24  spx-pe    cc4e.24dc.f166 N/A remote Ready
```

```
+----+
2/1| 1 |2/4
+----+
      +----+      +----+
1/1/3--2/3| 23 |2/5==2/5| 24 |2/4--1/1/16
      +----+      +----+
```

The example changes the ID for PE 18 to 23 and the ID for PE 17 to 24. At the end of the process, the SPX configuration is displayed, showing the new PE IDs.

7. Execute the **write memory** command to save the configuration.

```
ICX7750-48F Router# write memory
```

The following example uses the SPX interactive-setup utility to change two existing PE IDs.

```

ICX7750-48F Router# configure terminal
ICX7750-48F Router(config)# show running-config
Current configuration:
!
ver 08.0.50b1T203
!
stack unit 1
  module 1 icx7750-48-xgf-port-management-module
  module 2 icx7750-qsfp-6port-qsfp-240g-module
  module 3 icx7750-6q-6port-qsfp-240g-module
spx unit 17
  module 1 icx7250-24-port-management-module
  module 2 icx7250-sfp-plus-8port-80g-module
  spx-port 17/2/4
  spx-lag 17/2/5 to 17/2/6 17/2/8
spx unit 18
  module 1 icx7250-24-port-management-module
  module 2 icx7250-sfp-plus-8port-80g-module
  spx-port 18/2/3
  spx-lag 18/2/5 to 18/2/6 18/2/8
!
!
spx cb-enable
spx cb-configure
  zero-touch-enable
  spx-port 1/1/3
  spx-port 1/1/16
  zero-touch-ports 1/1/3 to 1/1/16
  pe-id 1/1/3 18 17 1/1/16
!
!
no inline power non-pd-detection enable
ip ssl min-version tls_1_1
!
!
interface management 1
!
!
end
ICX7750-48F Router(config)# spx cb-config
ICX7750-48F Router(config-spx-cb)# no zero-touch-enable      <-- You cannot run spx interactive-
                                                                setup when zero-touch is enabled.

ICX7750-48F Router(config-spx-cb)# end
ICX7750-48F Router# spx interactive-setup
You can abort spx interactive-setup at any stage by <ctrl-c>
0: quit
1: change PE IDs
2: discover and convert new units (no startup-config flash) to PEs
3: discover and convert existing/new standalone units to PEs
2&3 can also find new links and convert chain(s) to ring.
Please type your selection: 1
      +-----+           +-----+
      1/1/3--2/3| 18 |2/5==2/5| 17 |2/4--1/1/16
      +-----+           +-----+

Type "done" to finish, or a new ID for PE 18 (default 18): 23
Type "done" to finish, or a new ID for PE 17 (default 17): 24
Change IDs: 18->23, 17->24,
Do you want to proceed? (enter 'y' or 'n'): y
T=14m43.4: Sending new IDs to PE(s) 17-18...
power down ports to detach PEs: 1/1/3 1/1/16
power up ports: 1/1/3 1/1/16.
Affected PEs will join with new IDs.
Exit spx interactive-setup, reason: done ID changes
Sica Unit id:24, PoD License Capacity:8
Stack unit 24 Power supply 1 is up
Stack unit 24 Power supply 2 is down
Sica Unit id:23, PoD License Capacity:8
Stack unit 23 Power supply 1 is up

```

```
Stack unit 23 Power supply 2 is down
sh spx
T=17m13.2: alone: standalone, D: dynamic cfg, S: static
ID  Type      Role      Mac Address  Pri State  Comment
1   S  ICX7750-48XGF alone    cc4e.24d2.2c00  0 local  Ready
23  D  ICX7250-24   spx-pe    cc4e.24dc.e9ce N/A remote Ready
24  D  ICX7250-24   spx-pe    cc4e.24dc.f166 N/A remote Ready
```

```
+----+
2/1| 1 |2/4
+----+
+-----+ +-----+
1/1/3--2/3| 23 |2/5==2/5| 24 |2/4--1/1/16
+-----+ +-----+
ICX7750-48F Router# write memory
```

## Configuring SPX to Move PE Units without Changing IDs

You can move PE units to a new port and retain their current IDs with **spx allow-pe-movement** configured.

When **spx allow-pe-movement** is configured, the existing PE ID is used, and the **pe-id** configuration typically used in PE ID assignment is ignored. When you move a PE unit to a new port, the system detaches the port, and protocols register a "port down" event. When the PE joins with the same PE number on a new SPX port or LAG, the unit is treated as a new PE, and protocols initialize normally. All port configuration in the PE still applies.

### NOTE

When you move a PE to a different CB or PE port, make sure the CB or PE port is properly configured as an SPX port or SPX LAG.

### NOTE

You cannot use **spx allow-pe-movement** configuration to replace a faulty PE with another PE taken from the same Campus Fabric domain. The other PE will retain its ID. To avoid this problem, you can use the **no spx allow-pe-movement** command to remove the configuration, and then move and replace the PE. The replacement PE is then assigned the ID of the unit it is replacing.

### NOTE

RUCKUS recommends removing **spx allow-pe-movement** configuration once you are finished moving PE units. After removing the configuration, execute the **write memory** command.

Perform these steps to allow PEs to be moved and retain their current PE IDs.

1. Enter global configuration mode on the CB active controller.

```
device# configure terminal
```

2. Enter the **spx allow-pe-movement** command.

```
device(config)# spx allow-pe-movement
```

3. Move a PE, PE chain, or portion of a PE chain from one SPX port or LAG to another SPX port or LAG.

When the PE or PEs rejoin, the system assigns them the same ID they had before they were moved. The system generates PE ID configurations to represent the new topology.

4. Enter the **write memory** command to save the new configuration.

```
device(config)# write memory
```

The following example shows the Campus Fabric domain configuration prior to PE movement.

```
ICX7750-26Q Router# show spx
T=3h54m11.6: alone: standalone, D: dynamic cfg, S: static
ID   Type           Role      Mac Address      Pri State  Comment
1    S ICX7750-26QXG  standby  cc4e.24cf.2780  128 remote Ready
2    S ICX7750-26QXG  active   cc4e.24d1.9d80  128 local  Ready
17   S ICX7450-48G   spx-pe   609c.9f2a.5420  N/A remote Ready
18   S ICX7250-24    spx-pe   609c.9f42.0a28  N/A remote Ready
19   S ICX7250-24    spx-pe   0000.0000.0000  N/A reserve
51   S ICX7450-48G   spx-pe   609c.9f29.a560  N/A remote Ready
52   D ICX7450-48G   spx-pe   609c.9f2a.5be0  N/A remote Ready
53   D ICX7450-48G   spx-pe   609c.9f2a.54e0  N/A remote Ready
```

```

standby      active
+----+      +----+
2/4| 1 |2/1==2/1| 2 |
+----+      +----+
          +----+      +----+
2/1/1--4/1| 17 |2/1--2/3| 18 |2/2-
          +----+      +----+
          +----+      +----+      +----+
1/1/1--4/1| 51 |3/1--3/1| 52 |2/3--2/1| 53 |
          +----+      +----+      +----+
```

The following example configures the Campus Fabric domain so that PE units can retain their current IDs when the units are moved to different ports. In the example, PE unit 53 is moved from port 52/2/3 to port 18/2/2. PE unit 53 retains its ID (although it might have logically been assigned PE ID 19).

```
ICX7750-26Q Router# configure terminal
ICX7750-26Q Router(config)# spx allow-pe-movement
ICX7750-26Q Router(config)# show spx

!
!
!
T=4h2m50.3: alone: standalone, D: dynamic cfg, S: static
ID   Type           Role      Mac Address      Pri State  Comment
1    S ICX7750-26QXG  standby  cc4e.24cf.2780  128 remote Ready
2    S ICX7750-26QXG  active   cc4e.24d1.9d80  128 local  Ready
17   S ICX7450-48G   spx-pe   609c.9f2a.5420  N/A remote Ready
18   S ICX7250-24    spx-pe   609c.9f42.0a28  N/A remote Ready
19   S ICX7250-24    spx-pe   0000.0000.0000  N/A reserve
51   S ICX7450-48G   spx-pe   609c.9f29.a560  N/A remote Ready
52   D ICX7450-48G   spx-pe   609c.9f2a.5be0  N/A remote Ready
53   D ICX7450-48G   spx-pe   609c.9f2a.54e0  N/A remote Ready
```

```

standby      active
+----+      +----+
2/4| 1 |2/1==2/1| 2 |
+----+      +----+
          +----+      +----+      +----+
2/1/1--4/1| 17 |2/1--2/3| 18 |2/2--2/1| 53 |
          +----+      +----+      +----+
          +----+      +----+
1/1/1--4/1| 51 |3/1--3/1| 52 |2/3-
          +----+      +----+
```

```
ICX7750-26Q Router(config)# write memory
```

## Converting a Stack to a PE Chain or Ring

Pre-requisites:

- PE candidates must be clean units (with no startup-config).
- The CB must be enabled.
- The CB must be connected to the candidate PEs (the former stack).
- Because the procedure uses the SPX interactive-setup utility, the zero-touch utility must be disabled.

To convert an existing ICX 7150, ICX 7250, or ICX 7450 stack to a PE chain or ring, you must first dismantle the entire stack by issuing the **erase startup-config** command and then the **reload** command without saving the configuration on the stack active controller. The active controller erases the startup configuration of every unit in the stack and reloads every unit, including itself, as a new unit. This process is shown in the following example.

```
ICX7450-48F Router# show stack
T=6m11.5: alone: standalone, D: dynamic cfg, S: static
ID  Type      Role      Mac Address      Pri State  Comment
1  S ICX7450-48GF active  cc4e.246c.f190  128 local  Ready
2  S ICX7450-48G  standby cc4e.248b.77b0   0 remote Ready

      standby      active
      +----+      +----+
      | 2 |2/1==2/1| 1 |2/3
      +----+      +----+
Standby u2 - Learn other units for 4 sec, protocols may not be ready in 66 s.
Current stack management MAC is cc4e.246c.f190
ICX7450-48F Router#
ICX7450-48F Router#
ICX7450-48F Router# erase startup-config
T=6m26.9: Erase request sent to unit 2
Erase startup-config Done.
dhcp server lease database is also removed
stacking/spx pe flash file is also removed
ICX7450-48F Router# reload
Are you sure? (enter 'y' or 'n'): y
Could not verify if the Running Config data has been changed.
Do you want to continue the reload anyway? (enter 'y' or 'n'): y
ICX7450-48F Router#T=6m38.6: Reload request sent to attached stack member(s): 2...

Will reload in 3 seconds
T=6m41.6: Halt and reboot
```

Follow the zero-touch or SPX interactive-utility procedure, and include the following steps.

1. If the stack is to be connected to CB ports, configure **zero-touch-ports** or an SPX port or SPX LAG on the CB. If the stack is to be connected to an edge PE, the connection must be through a non-base-module port on the PE.
2. Connect at least one non-base module port of the old stack to the CB or an edge PE.
3. Configure **zero-touch-enable** or run the SPX interactive-setup utility. If the old stack is a ring, run the SPX interactive-setup utility because it allows users to remove links between two units to break a ring.
4. If the old stack is a ring, physically remove links to break the ring before running the SPX interactive-setup utility.



The following example uses `spx interactive-setup` to discover and add a connected ring of two PEs (ICX 7250 units).

```

ICX7750-48F Router# configure terminal
ICX7750-48F Router(config)# spx cb-enable
System is now in 802.lbr control bridge (CB) mode.
ICX7750-48F Router(config)# spx cb-config
ICX7750-48F Router(config-spx-cb)# spx-port 1/1/3
ICX7750-48F Router(config-spx-cb)# spx-port 1/1/16
ICX7750-48F Router# spx interactive-setup
You can abort spx interactive-setup at any stage by <ctrl-c>
0: quit
1: change PE IDs
2: discover and convert new units (no startup-config flash) to PEs
3: discover and convert existing/new standalone units to PEs
2&3 can also find new links and convert chain(s) to ring.
Please type your selection: 2
Probing topology to find new units...
Horizontal bars link to discovered units. Vertical bars link to CB or PEs.
#1: icx7250-24-port-management-module CC4E.24DC.E9CE
#2: icx7250-24-port-management-module CC4E.24DC.F166
  1/1/3          1/1/16
  |             |
  |             |
  2/3          2/4
+----+        +----+
| 1 |2/5==2/5| 2 |
+----+        +----+
Discovered 1 chain/ring
chain #0: Do you want to select this chain?(enter 'y' or 'n'): y
#1: icx7250-24-port-management CC4E.24DC.E9CE, type an ID (No: 0, default: 17): <-- You can change
the default id,
or just type
enter to use
the default.

#2: icx7250-24-port-management CC4E.24DC.F166, type an ID (No: 0, default: 18):
2 unit(s) selected: #1: ID=17, #2: ID=18,
      #1          #2
+----+        +----+
1/1/3--2/3| 17 |2/5==2/5| 18 |2/4--1/1/16
+----+        +----+
Will produce the above topology. Do you accept it? (enter 'y' or 'n'): y
spx interactive-setup discovers 1 chain(s). valid #=1, selected #=1
Send reload to chain0: #1 CC4E.24DC.E9CE ID=17, D0: 2/3, D1: 2/5 to 2/6 2/8
#2 CC4E.24DC.F166 ID=18, D0: 2/5 to 2/6 2/8, D1: 2/4
U18-MSG: PS 1, Internal Power supply is up.
Sica Unit id:18, PoD License Capacity:8
Sica Unit id:17, PoD License Capacity:8
ICX7750-48F Router# show spx
T=42m39.1: alone: standalone, D: dynamic cfg, S: static
ID Type Role Mac Address Pri State Comment
1 S ICX7750-48XGF alone cc4e.24d2.2c00 0 local Ready
17 D ICX7250-24 spx-pe cc4e.24dc.e9ce N/A remote Ready
18 D ICX7250-24 spx-pe cc4e.24dc.f166 N/A remote Ready

      +----+
      2/1| 1 |2/4
      +----+

      +----+        +----+
      1/1/3--2/3| 17 |2/5==2/5| 18 |2/4--1/1/16
      +----+        +----+
ICX7750-48F Router# write memory
    
```

## Converting a PE Chain or Chains to a Ring

Follow these steps to discover new physical links between a CB and an edge PE or between two edge PEs and form a PE ring from one or two PE chains.

1. Make all necessary physical connections between two edge PEs or between an edge PE and the CB. At least one end of the link must be one of these port types:
  - CB SPX port or SPX LAG member with no live PE link
  - CB port with zero-touch port configuration
  - Edge PE port on a non-base-module (2, 3, and 4 are non-base modules), excluding upstream SPX port or SPX LAG members and ports with configuration. In this case, the edge PE is the last unit of a PE chain.
2. (Optional, recommended) Connect multiple links between two units. The system will generate an SPX LAG connection on both units that includes all the links.
3. Initiate the conversion in one of these ways:
  - In EXEC mode, enter the **spx interactive-setup** command, and select either option 2 or 3 when prompted.

```
ICX7750-26Q Router# spx interactive-setup
You can abort spx interactive-setup at any stage by <ctrl-c>
CBPE17PE18PE20PE21PE24data portPE21PE241G10Ga) T-connectionb) CB data portsd) different
speedsPE21PE24c) PE data ports have configurationconfig
0: quit
1: change PE IDs
2: discover and convert new units (no startup-config flash) to PEs
3: discover and convert existing/new standalone units to PEs
2&3 can also find new links and convert chain(s) to ring.
Please type your selection: 2
Probing topology to find new units...
```

- Enable zero-touch provisioning.

```
ICX7750-26Q Router(config)# spx cb-config
ICX7750-26Q Router(config-spx-cb)# zero-touch-enable
```

New links are detected. Any invalid connection is reported in a system message, and you are asked to remove it. Valid connections and ring formation are reported in system output.

The following example shows a warning message received after an invalid connection was detected.

```
Warning! The following 1 logical link(s) are invalid. Please remove them because they may cause
loops.
CB--PE17: error: CB 1/1/5 isn't spx-port/lag or ZTP-ports, 2 link(s): 1/1/5-17/3/1 1/1/7-17/4/1
Spx interactive-setup does not find any new unit
spx interactive-setup detects invalid topology, aborts
```

The following example shows a system message received when a valid connection is detected that cannot be handled by the system. In this case, you are requested to use the **multi-spx-port** or **multi-spx-lag** command to add the link, or to remove the link to avoid loops.

```
The following 1 logical link(s) would expand existing spx-port/lag. They are not handled.
Please manually use "multi-spx-port/lag" to add the link to existing spx-port/lag, or remove them
because they may cause loops.
PE17--PE27: 1 link(s): 17/2/1-27/2/1
```

4. After the process completes, enter the **write memory** command to save the newly generated SPX port and SPX LAG configuration.

The following example shows SPX interactive-setup discovery of new links and conversion of two PE chains to a PE ring. Zero-touch provisioning works the same way but does not ask for user confirmation.

```

ICX7750-26Q Router# spx interactive-setup
You can abort spx interactive-setup at any stage by <ctrl-c>
CBPE17PE18PE20PE21PE24data portPE21PE241G10Ga) T-connectionb) CB data portsd) different speedsPE21PE24c) PE
data ports have configurationconfig
0: quit
1: change PE IDs
2: discover and convert new units (no startup-config flash) to PEs
3: discover and convert existing/new standalone units to PEs
2&3 can also find new links and convert chain(s) to ring.
Please type your selection: 2
Probing topology to find new units...
Detect 2 new links (classified to 1 logical link) between existing units.
New logical link 0: =====
+----+ +----+ +----+ +----+
2/1/9--4/1| 23 |2/1==2/1| 24 |2/5==2/1| 25 |2/5==2/5| 26 |
+----+ +----+ +----+ +----+
+----+ +----+
1/1/5==3/1| 17 |2/1==2/1| 27 |
+----+ +----+
The new logical link (PE26--PE27: 2 link(s): 26/2/1-27/2/3 26/2/2-27/2/4) will make the above two chains to
form a ring.
Do you want to select this link? (enter 'y' or 'n'): y
spx interactive-setup discovers 1 link (valid#= 1, selected#= 1) and 0 chain
ICX7750-26Q Router#T=53m40.8: Add spx-lag 26/2/1 to 26/2/2 for PE 26 to form a ring. Please do "write
memory".
T=53m40.8: Add spx-lag 27/2/3 to 27/2/4 for for PE 27 to form a ring. Please do "write memory".

ICX7750-26Q Router# write memory
ICX7750-26Q Router# show spx
... snipped
active standby
+----+ +----+ +----+
=2/1| 2 |2/4--2/4| 3 |2/1==2/1| 1 |2/4=
| +----+ +----+ +----+ |
|-----|
+----+ +----+ +----+ +----+ +----+ +----+
1/1/5==3/1| 17 |2/1==2/1| 27 |2/3==2/1| 26 |2/5==2/5| 25 |2/1==2/5| 24 |2/1=
+----+ +----+ +----+ +----+ +----+ +----+
+----+
2/1/9--4/1| 23 |2/1=
+----+

```

## Downloading Images to New Units Before Converting Them to PEs with SPX Interactive-setup or Zero-touch Provisioning

Zero-touch provisioning and SPX interactive-setup can detect standalones running different software images before they reload them as PEs. However, the PEs with mismatched software images are put into non-operational state when they join the SPX system. If the **tftp-server** command is configured, the CB copies new images to non-operational PEs. You also have the option to copy the images manually to all PEs using the **copy tftp flash** command. After the new image has been copied, the new PEs can be reloaded so that they run the correct image. There are a few drawbacks to the overall process:

1. The process requires two reloads. First, the standalone must be reloaded as a PE. Then, after any PE with a mismatched image has joined the SPX system and the correct image has been copied to it, it must be reloaded to run the correct image.
2. Due to the difference in IPC version, a PE running a different major image (for example, a release 08.0.61 image instead of an 08.0.70 image) may not join the SPX system. In this case, you cannot use SPX system capabilities to copy images from the CB to the PE unit.
3. Any PE running a different image is put into non-operational state and has very limited function. For example, all data ports are in the down state.

From release 08.0.70, if new units are running a different software image, zero-touch provisioning and SPX interactive-setup downloads the correct image to the new units before reloading them as PEs.

**NOTE**

A new unit is one that does not have startup-config flash. You can create a new unit by removing startup-config with the **erase startup-config** command followed by the **reload** command.

For zero-touch provisioning or SPX interactive-setup to download images, you must first configure the **tftp-server** command with the location of the correct images. When the **tftp-server** command is not configured or **image-auto-copy** is disabled, zero-touch provisioning and SPX interactive-setup respond differently. The following table summarizes the differences in behavior.

**TABLE 8** Differences in SPX Interactive-setup and Zero-touch Image Download Behavior

Utility	tftp-server Configured	image-auto-copy Disabled or tftp-server Not Configured
SPX interactive-setup	download image	Asks for user confirmation to abort or reload new units as PEs without downloading images
Zero-touch provisioning	download image	Prints a messages, generates a syslog entry, and aborts

Here are some additional key points about how SPX interactive-setup and zero-touch provisioning handle image downloads.

1. Zero-touch provisioning discovers only new units. SPX interactive-setup detects new units as well as other units with configuration. However, SPX interactive-setup does not copy images to any units that are not new, even if they are running a different image. Instead, it prints a message similar to the following example asking you to indicate whether to abort or to convert all units to PEs without downloading images.
 

```
Proceeding will produce the above topology. Do you accept it? (enter 'y' or 'n'): y
spx interactive-setup discovers 1 chain (valid#= 1, selected#= 1)
Detects 4 units running different images but 1 unit (17) are not clean units.
You can abort (y) or proceed (n) without downloading images: (enter 'y' or 'n'): n
SYSLOG: <14> Apr 14 11:48:38 INTERACTIVE SETUP: Send reload to chain 0
```
2. SPX interactive-setup and zero-touch provisioning print a message and abort when any image download to a unit fails, even if some unit downloads were successful.
3. SPX interactive-setup and zero-touch provisioning do not download images to new units that are running the same image as the SPX system.
4. SPX interactive-setup and zero-touch provisioning must wait for all image downloads to complete before reloading any unit as a PE.

The following example shows an image download using SPX interactive-setup.

```
ICX7750-26Q Router# spx interactive-setup
You can abort spx interactive-setup at any stage by <ctrl-c>
0: quit
1: change PE IDs
2: discover and convert new units (no startup-config flash) to PEs
3: discover and convert existing/new standalone units to PEs
2&3 can also find new links and convert chain(s) to ring.

Please type your selection: 2
Probing topology to find new units...
Horizontal bars link to discovered units. Vertical bars link to CB or PEs.
#1: icx7450-48p-poe-management 609C.9F2A.D460 (image mismatch: SPR08070b1TEST)
#2: icx7450-48p-poe-management 609C.9F2A.97E0
#3: icx7250-24-port-management 609C.9F04.6F90 (image mismatch: SPR08070b1TEST)
#4: icx7250-24-port-management 609C.9F04.68AC (image mismatch: SPR08070b1TEST)
#5: icx7250-24-port-management 609C.9F04.5E68
#6: icx7450-48f-sf-port-management CC4E.246C.F190
1/1/5
```

```

  ||
  ||
  3/1
+-----+           +-----+           +-----+           +-----+           +-----+
| 1 | |2/1==2/1| 2 | |2/3==2/1| 3 | |2/5==2/5| 4 | |2/1==2/5| 5 | |2/1=
+-----+           +-----+           +-----+           +-----+           +-----+
                                                                    |
                                                                    |
                                                                    +-----+
                                                                    | 6 | |2/1=
                                                                    +-----+
                                                                    |
                                                                    4/1
                                                                    |
                                                                    |
                                                                    2/1/9
  
```

```

Discovered 1 chain/ring
Chain #0: Do you want to select this chain? (enter 'y' or 'n'): y
#1: icx7450-48p-poe 609C.9F2A.D460, *** image mismatch, type an ID (No: 0, default: 17):
#2: icx7450-48p-poe 609C.9F2A.97E0, type an ID (No: 0, default: 18):
#3: icx7250-24-port 609C.9F04.6F90, *** image mismatch, type an ID (No: 0, default: 21):
#4: icx7250-24-port 609C.9F04.68AC, *** image mismatch, type an ID (No: 0, default: 28):
#5: icx7250-24-port 609C.9F04.5E68, type an ID (No: 0, default: 29):
#6: icx7450-48f-sf-port CC4E.246C.F190, type an ID (No: 0, default: 32):
You selected 6 unit(s): #1: ID=17, #2: ID=18, #3: ID=21, #4: ID=28, #5: ID=29, #6: ID=32,
  
```

```

             #1             #2             #3             #4             #5
             +-----+           +-----+           +-----+           +-----+           +-----+
1/1/5==3/1| 17 | |2/1==2/1| 18 | |2/3==2/1| 21 | |2/5==2/5| 28 | |2/1==2/5| 29 | |2/1=
+-----+           +-----+           +-----+           +-----+           +-----+
                                                                    #6
                                                                    +-----+
                                                                    |
                                                                    2/1/9--4/1| 32 | |2/1=
                                                                    +-----+
  
```

```

Proceeding will produce the above topology. (** NOTE: #1 #3 #4 will download image) Do you accept it?
(enter 'y' or 'n'): y
spx interactive-setup discovers 1 chain (valid#= 1, selected#= 1)
Note: must download images to 3 new unit(s): #17,21,28
SYSLOG: <14> Apr 13 19:42:19 INTERACTIVE SETUP: spx interactive-setup discovers 1 chain (valid#= 1,
selected#= 1)
SYSLOG: <14> Apr 13 19:42:19 System: Image mismatch Auto Copy Started for primary image for units 17 21 28
Load to buffer (8192 bytes per dot)
.....
.....
.....
.....
.....
.....
.....
.....PLEASE WAIT.
MEMBERS SYNCING IMAGE TO FLASH. DO NOT SWITCH OVER OR POWER DOWN THE UNIT...
TFTP to Flash Done
  
```

The following example shows an image download using zero-touch provisioning. Zero-touch provisioning does not display the topology diagram. It displays some messages and syslog entries.

```

Zero-touch discovers 1 chain (valid#= 1)
Note: must download images to 4 new unit(s): #17,21,28,32
SYSLOG: <14> Apr 14 01:06:21 ZTP: zero-touch-enable detects total 1 chains (6 units). unstable=0,
SYSLOG: <14> Apr 14 01:06:21 ZTP: Zero-touch discovers 1 chain (valid#= 1)
SYSLOG: <14> Apr 14 01:06:21 System: Image mismatch Auto Copy Started for primary image for units 17 21 28
32
Load to buffer (8192 bytes per dot)
.....
.....
.....
.....
.....
.....
.....
.....PLEASE WAIT.
  
```

## Campus Fabric Configuration Overview and Interactive Configuration

### SPX Interactive-setup

```
.....PLEASE WAIT.
MEMBERS SYNCING IMAGE TO FLASH. DO NOT SWITCH OVER OR POWER DOWN THE UNIT...
TFTP to Flash Done
SYSLOG: <14> Apr 14 01:09:19 ZTP: Send reload to chain 0
```

The following examples illustrate SPX interactive-setup and zero-touch provisioning behavior when the TFTP server is not configured.

### SPX Interactive-setup

```
Snipped ...
You selected 6 unit(s): #1: ID=17, #2: ID=18, #3: ID=21, #4: ID=28, #5: ID=29, #6: ID=32,
      #1          #2          #3          #4          #5
      +-----+   +-----+   +-----+   +-----+   +-----+
1/1/5==3/1| 17 |2/1==2/1| 18 |2/3==2/1| 21 |2/5==2/5| 28 |2/1==2/5| 29 |2/1=
      +-----+   +-----+   +-----+   +-----+   +-----+ |
                                                    #6      |
                                                    +-----+ |
                                                    2/1/9--4/1| 32 |2/1=
                                                    +-----+

Proceeding will produce the above topology. (** NOTE: #1 #3 #4 has different image) Do you accept it?
(enter 'y' or 'n'): y
spx interactive-setup discovers 1 chain (valid#= 1, selected#= 1)
Detects 3 units running different images but "tftp-server" is not configured.
You can abort (y) or proceed (n) without downloading images: (enter 'y' or 'n'): y
Exit spx interactive-setup, reason: User aborts
```

### Zero-touch Provisioning

Zero-touch provisioning runs in background. It does not display any topology diagrams. However, it prints messages and syslog entries.

```
Zero-touch discovers 1 chain (valid#= 1)
ZTP detects 3 units running different images, but "tftp-server" is not configured. Abort
SYSLOG: <14> Mar 24 19:59:14 ZTP: zero-touch-enable detects total 1 chains (6 units). unstable=0,
```

# Campus Fabric Manual Configuration

- Enabling and Configuring the Control Bridge..... 71
- How PE Units Join a Campus Fabric Domain..... 73
- Manually Enabling and Configuring PE Units..... 74
- Campus Fabric Detailed Manual Configuration Example..... 88

## Enabling and Configuring the Control Bridge

To be manually configured, a PE must run a router image because **spx pe-enable** configuration is not available in the switch image. In contrast, Zero-touch deployment and SPX interactive-setup can discover a standalone running either the router or switch image and reload it to a PE.

The following procedure assumes that the core stack of ICX devices that will become the control bridge (CB) is connected and functioning, and that the ICX ports in the stack to be used as SPX connections have been identified.

### NOTE

The following procedure describes CB configuration from an ICX stack. The same procedure can be performed from a standalone ICX 7650, ICX 7750, or ICX 7850. The only restriction is that the same port cannot be configured as a stacking port or trunk and as an SPX port or LAG.

1. In global configuration mode on the active controller for the stack that will serve as the control bridge (CB), enter the **spx cb-enable** command.

```
ICX7750-26Q Router# configure terminal
ICX7750-26Q Router(config)# spx cb-enable
System is now in 802.lbr control bridge (CB) mode.
```

### NOTE

The CB must be running LLDP to support a Campus Fabric environment. If LLDP is not already running, it is enabled on SPX ports by the **spx cb-enable** command. Enabling or disabling SPX does not affect LLDP on data ports, and enabling or disabling LLDP on data ports does not affect enabled SPX ports.

### NOTE

When spanning tree is configured on the standalone unit or stack, the **spx cb-enable** command requires a reload. After you enter the command, the system prompts you that spanning tree configuration is present and requires you to confirm the reload before the CB is enabled. CB units but not PE units are reloaded when you confirm. Disabling the CB with the **no spx cb-enable** command also requires a reload if spanning tree configuration is present.

2. Still in global configuration mode on the active controller, use the **spx cb-configure** command to enter CB configuration mode as shown in the following example.

```
ICX7750-26Q Router(config)# spx cb-configure
ICX7750-26Q Router(config-spx-cb)# ?
multi-spx-lag          Configure two lags of a live link
multi-spx-port        Configure two ports of a live link
pe-id                 PE ID assignment provision
spx-lag               Configure one CB lag
spx-port              Configure one or more CB ports
zero-touch-enable     actively send probe
zero-touch-ports      Configure zero touch ports
```

- Use the **spx-port** command followed by an appropriate port number and an optional group name to designate a port that will be used to connect to attached PE units.

**NOTE**

The **pe-group name** option appears in SPX show commands and can be included as a PE port identifier in the **spx pe-id** command.

The following example creates an SPX port on CB unit 1.

```
ICX7750-26Q Router(config-spx-cb) # spx-port 1/1/10
```

The following example creates an SPX port on CB unit 2 and gives it a group name.

```
ICX7750-26Q Router(config-spx-cb) # spx-port 2/1/1 pe-group bldg1-stk7
```

- Configure CB LAGs (trunks) as needed. Use the **spx-lag** command followed by an appropriate port range and an optional group name to designate the CB LAG.

**NOTE**

An SPX LAG can contain from 2 through 16 ports. ICX 7650, ICX 7750, or ICX 7850 CB units, ICX 7450 PE units, and ICX 7250 PE units support a maximum of 16 ports in an SPX LAG. ICX 7150 PE units support a maximum of 8 ports.

**NOTE**

The rules governing LAG ranges in conjunction with port lists are covered in [Differences in Campus Fabric Configuration Practices](#) on page 42.

The following example creates one end of a two-port SPX LAG on CB unit 2.

```
ICX7750-26Q Router(config-spx-cb) # spx-lag 2/1/10 to 2/1/11
```

The following example creates one end of a two-port CB LAG. The LAG includes ports from CB unit 2 and CB unit 3.

```
ICX7750-26Q Router(config-spx-cb) # spx-lag 2/1/10 to 2/1/11 3/1/10
```

The following example creates one end of a CB LAG. The trunk is given a group name.

```
ICX7750-26Q Router(config-spx-cb) # spx-lag 3/1/3 to 3/1/5 pe-group bldg1-finance
```

## Adding a Reserved PE Configuration on the CB

PE unit configuration present in the CB active controller before the corresponding PE unit joins the CB is called reserved PE configuration.

**NOTE**

It is not necessary to configure a reserved PE configuration for a PE to join. The CB learns module and SPX port or LAG information from the PE if the assigned ID has no reserved configuration.

You can create PE configuration on the CB to be applied later to a joining PE unit. You must specify an SPX unit number and the ICX 7150, ICX 7250, or ICX 7450 modules that match the new PE unit.

When you configure a reserved PE unit on the CB, the system does not generate any SPX ports by default. The system learns SPX ports or LAGs from the PE unit when it joins. If you configure SPX ports or LAGs as part of a reserved unit, the CB will push your port or LAG configuration to the PE unit when it joins, after checking that the SPX port or LAG configuration will not break its connection with the PE.



#### NOTE

PE ID assignment is based on the **pe-id** configuration under the **spx cb-configure** command. If the joining PE port does not match any **pe-id** configuration, it is assigned its old ID if it is available. If the joining unit has no old ID or the old ID is not available, it is assigned an unused ID.

The following example shows SPX unit 20 being created on the CB as a reserved configuration.

```
ICX7750-26Q Router# configure terminal
ICX7750-26Q Router(config)# spx unit 20
ICX7750-26Q Router(config-spx-unit-20)# module 1 ?
  icx7450-24-port-management-module
  icx7450-24p-poe-port-management-module
  icx7450-32zp-poe-management-module
  icx7450-48-port-management-module
  icx7450-48f-sf-port-management-module
  icx7450-48p-poe-management-module
ICX7750-26Q Router(config-spx-unit-20)# module 1 icx7450-48-port-management-module
ICX7750-26Q Router(config-spx-unit-20)# module 2 ?
  icx7400-sfp-4port-4g-module
  icx7400-xgc-4port-40g-module
  icx7400-xgf-4port-40g-module
ICX7750-26Q Router(config-spx-unit-20)# module 2 icx7400-xgf-4port-40g-module
```

Once you have configured a reserved PE unit, you can verify your configuration by entering the **show running-config** command. Configured modules are listed, along with SPX ports or LAGs, if any. SPX unit 20 configuration, a reserved PE configuration, is displayed after stack unit configuration. The following example shows no SPX ports. SPX ports or LAGs will be learned and added to the configuration when a matching PE joins the CB.

```
ICX7750-26Q Router(config-spx-unit-20)# show running-config

Current configuration:
!
ver 08.0.40b1T203
!
stack unit 1
  module 1 icx7750-20-qxg-port-management-module
  module 2 icx7750-qsfp-6port-qsfp-240g-module
  module 3 icx7750-6q-6port-qsfp-240g-module
  priority 128
  stack-trunk 1/2/4 to 1/2/5
  stack-port 1/2/1 1/2/4
stack unit 2
  module 1 icx7750-20-qxg-port-management-module
  module 2 icx7750-qsfp-6port-qsfp-240g-module
  module 3 icx7750-6q-6port-qsfp-240g-module
  stack-trunk 2/2/1 to 2/2/2
  stack-trunk 2/2/4 to 2/2/6
  stack-port 2/2/1 2/2/4
spx unit 20
  module 1 icx7450-48-port-management-module
  module 2 icx7400-xgf-4port-40g-module
stack enable
stack mac 748e.f8f9.6300
!
```

## How PE Units Join a Campus Fabric Domain

A PE unit cannot join a CB unless the CB has been enabled. Refer to [Enabling and Configuring the Control Bridge](#) on page 71.

PE discovery starts when a link is detected on a CB or PE port with a potential link to another PE-capable unit. Each PE unit has two reconfigurable SPX ports or LAGs over which LLDP exchanges messages with the CB. When a port in a standalone CB or a CB stack receives a join (LLDP Port-Extension) request from the SPX ports or LAGs of a potential PE unit, the connection process is initiated. When an SPX port on a PE is configured as part of a PE trunk, the join request is sent on all ports in the trunk.

During a PE join, the following PE information is sent to the CB and stored as unit configuration:

- Module information
- Ports on which the PE is joining
- SPX ports
- SPX LAGs
- Software image version

## How the CB Applies a Reserved Configuration

If the CB has a reserved PE configuration for the same PE ID that does not match the physical configuration of the joining PE, the following scenarios result in different actions:

- The modules are different (for example, the PE has a 24-port base module, and the reserved configuration has a 48-port module). The joined PE is put into a nonoperational state. The user can configure the **no spx unit number** command to remove the reserved configuration, and the CB learns the PE properly.
- The PE has extra modules. The CB learns the extra modules.
- The reserved PE configuration has extra modules. The CB keeps the extra modules.
- The reserved PE configuration has different SPX ports or LAGs from the PE. The CB uses the reserved PE configuration and pushes it to the PE, but if reserved PE configuration might break connections, the CB learns the physical connections.

## If the PE Unit Has No Reserved Configuration

After a PE joins, if the assigned PE ID does not have a reserved configuration, the CB creates an **spx unit number** configuration that contains the PE module along with SPX port and LAG information. The information is retained in memory unless the user enters the **write memory** command on the CB to save the configuration to the startup configuration file.

## If the PE Unit Has a Different Software Image

The CB checks the software image version to make sure the CB and the PE unit are running compatible images. If the PE unit is running a different image version, it is put in a nonoperational state. The CB can copy the correct image to a nonoperational unit. Refer to [Campus Fabric \(SPX\) Image Upgrade](#) on page 133 for more information.

# Manually Enabling and Configuring PE Units

The following procedure requires an ICX 7150, ICX 7250, or ICX 7450 unit with a router image that has stacking disabled (**no stack enable** configuration) and that is properly connected to an enabled control bridge (CB).

The following steps are involved in configuring PE units.

- Enable the PE unit.
- Configure SPX ports, if necessary, to change the ports for setting up LLDP communications with the CB.
- Configure SPX LAGs as needed.
- Save and load the configuration.

### NOTE

For information on PE ring formation, refer to [Best practices for PE ring configuration](#) on page 34.

**NOTE**

For information on automatic configuration of PE units, refer to [Zero-touch Configuration](#) on page 52. For information on automated interactive configuration of PE units, refer to [SPX Interactive-setup](#) on page 57.

1. To enable an ICX 7150, ICX 7250, or ICX 7450 unit as a PE unit, enter the **spx pe-enable** command on the unit in global configuration mode.

```
ICX7450-48F Router# configure terminal
ICX7450-48F Router(config)# spx pe-enable
Enter provisional PE mode. CLI is limited to spx unit 1.
After finishing all configuration, please "write memory" and reload this unit to be a PE.
```

The unit switches immediately from regular mode to Provisional-PE mode. The global configuration prompt changes to include the prefix [Provisional-PE].

2. Confirm that the PE is enabled by entering the **show running-config** command.

```
[Provisional-PE]ICX7450-48P Router# show running-config
Current configuration:
!
ver 08.0.80B7T213
!
spx pe-enable
spx unit 1
  module 1 icx7450-48p-poe-management-module
  module 2 icx7400-xgc-4port-40g-module
  module 3 icx7400-qsfp-lport-40g-module
  module 4 icx7400-qsfp-lport-40g-module
  spx-port 1/2/1

  spx-port 1/2/3
!
End
```

The unit is shown as enabled and its SPX configuration is shown as spx unit 1 (the local designation for the new PE unit). In the previous example, the system has provisionally configured ports 1/2/1 and 1/2/3 as SPX ports.

**NOTE**

An ICX 7450 provisionally configured as a PE contains system-generated SPX ports 1/2/1 and 1/2/3 for a 4 X 10-Gbps module. These ports can be reconfigured as shown in the following steps. Refer to [SPX Port and LAG Configuration Rules](#) on page 82 for more information on system-generated SPX ports.

3. (Optional) Designate a suggested PE ID with the **spx suggested-id** command.

```
[Provisional-PE]ICX7450-48P Router(config)# spx suggested-id 20
```

**NOTE**

Allowable PE IDs are 17 through 56.

**NOTE**

The **spx suggested-id** command is not available on the CB. It can be entered only in Provisional-PE or PE mode.

**NOTE**

The suggested ID entered cannot be assigned if the CB receives other configuration information for the PE. The suggested ID is not assigned if it is already assigned to another unit or if it is present in another PE ID configuration.

4. Enter SPX unit configuration mode.

```
[Provisional-PE]ICX7450-48P Router(config)# spx unit 1
```

5. Configure SPX ports if necessary.

In the following example, one of the default SPX ports is removed, and another SPX port is created.

```
[Provisional-PE]ICX7450-48P Router(config-spx-unit-1)# no spx-port 1/2/3
spx-port 1/2/3 is removed
[Provisional-PE]ICX7450-48P Router(config-spx-unit-1)# spx-port 1/2/4
```

6. Configure SPX LAGs for the PE unit if needed.

In the following example, the default SPX port 1/2/1 becomes part of a two-port LAG.

```
[Provisional-PE]ICX7450-48P Router(config-spx-unit-1)# spx-lag 1/2/1 to 1/2/2
```

7. Assign or change the PE name if needed.

In the following example, the PE unit is named "finance".

```
[Provisional-PE]ICX7450-48P Router(config-spx-unit-1)# pe-name finance
```

8. If the CB has jumbo mode configured, you can configure jumbo mode on a provisional PE to avoid one extra reload after the PE reloads and joins the CB. (If either the CB or PE has jumbo mode configured and the other does not, the PE is reloaded after it joins the CB. When it boots up, it joins the CB again and has the same jumbo mode configuration as the CB.)

The following example configures jumbo mode on a provisional PE.

```
[Provisional-PE]ICX7450-48P Router(config-spx-unit-1)# jumbo
```

9. Check your completed configuration with the **show running-config** command.

The following example shows the new configuration, which has yet to be saved and loaded.

```
[Provisional-PE]ICX7450-48P Router(config-spx-unit-1)# show running-config
Current configuration:
!
ver 08.0.80B7T213
!
spx pe-enable
spx suggested-id 20
spx unit 1
  pe-name finance
  module 1 icx7450-48p-poe-management-module
  module 2 icx7400-xgc-4port-40g-module
  module 3 icx7400-qsfp-lport-40g-module
  module 4 icx7400-qsfp-lport-40g-module
  spx-lag 1/2/1 to 1/2/2
  spx-port 1/2/4
!
jumbo
!
End
```

10. Enter the **write memory** command to save the new configuration to the PE startup file.

```
[Provisional-PE]ICX7450-48P Router(config-spx-unit-1)# exit
[Provisional-PE]ICX7450-48P Router(config)#write memory
Flash Memory Write (162 bytes)
[Provisional-PE]ICX7450-48P Router(config)#
Write PE startup file done.
```

11. Enter the **reload** command to reboot the system with the new configuration.

```
[Provisional-PE]ICX7450-48P Router# reload
Are you sure? (enter 'y' or 'n'): y
Unmounting the External USB
We are in system resetDisabled core-1
CPU Sampling disabled.
The system is going down NOW!!!
```

The unit moves from Provisional-PE mode to PE mode. Then, if a connected CB is enabled, it becomes an active PE. The CB takes control of the PE and may assign a different unit ID.

## Campus Fabric Manual Configuration

### Manually Enabling and Configuring PE Units

The transition from provisional to active PE unit under CB control is shown in the following example. As indicated in the example, the PE is assigned a new unit ID and a different SPX LAG, based on reserved configuration information stored on the CB. The proposed name for the PE is not assigned.

```
Ruckus Wireless Bootloader: 10.1.12b001T215 (Mar 28 2018 - 00:00:53)
```

```
Validate Shmoo parameters stored in flash ..... OK
```

```
Restoring Shmoo parameters from flash .....
```

```
Running simple memory test ..... OK
```

```
ICX7450-48 Copper (POE), PVT1
```

```
SYS CPLD VER: 0x10, Released Ver: 0
```

```
Enter 'b' to stop at boot monitor: 0
```

```
bootdelay: ==
```

```
Booting image from Primary
```

```
.....  
.....  
.....
```

```
...## Booting kernel from FIT Image at 70000200 ...
```

```
Using 'conf@2' configuration
```

```
Trying 'kernel@1' kernel subimage
```

```
Description: Ruckus Linux SP/SI
```

```
Type: Kernel Image
```

```
Compression: lzma compressed
```

```
Data Start: 0x700002d0
```

```
Data Size: 2178385 Bytes = Architecture: ARM
```

```
OS: Linux
```

```
Load Address: 0x61008000
```

```
Entry Point: 0x61008000
```

```
Hash algo: crc32
```

```
Hash value: fa26f214
```

```
Verifying Hash Integrity ... crc32+ OK
```

```
## Loading init Ramdisk from FIT Image at 70000200 ...
```

```
Using 'conf@2' configuration
```

```
Trying 'ramdisk@1' ramdisk subimage
```

```
Description: Ramdisk -rootfs
```

```
Type: RAMDisk Image
```

```
Compression: lzma compressed
```

```
Data Start: 0x70430060
```

```
Data Size: 25319571 Bytes = Architecture: ARM
```

```
OS: Linux
```

```
Load Address: 0x00000000
```

```
Entry Point: 0x00000000
```

```
Hash algo: crc32
```

```
Hash value: 4acb6356
```

```
Verifying Hash Integrity ... crc32+ OK
```

```
## Flattened Device Tree from FIT Image at 70000200
```

```
Using 'conf@2' configuration
```

```
Trying 'fdt@1' FDT blob subimage
```

```
Description: Flattened Device Tree blob
```

```
Type: Flat Device Tree
```

```
Compression: uncompressed
```

```
Data Start: 0x70429790
```

```
Data Size: 8922 Bytes = Architecture: ARM
```

```
Hash algo: crc32
```

```
Hash value: 10a00dea
```

```
Verifying Hash Integrity ... crc32+ OK
```

```
Loading FDT from 0x70429790 to 0x65008000
```

```
Booting using the fdt blob at 0x65008000
```

```
Uncompressing Kernel Image ... OK
```

```
Using Device Tree in place at 65008000, end 6500d2d9
```

The kernel is started, factory defaults are applied, and the device is initialized as a PE.

```
Starting kernel ...

bcmiproc-gmac 18023000.ethernet: can't find MAC address
booting with 4.4 kernel
PLATFORM SP
SP's eUSB-Infra Called
  Number of eUSB partitions 3 ...
PLATFORM SP
Config partition mounted.
eUSB flash drive is ready No External USB Drive(s) Mounted . Enabling core#1
core#1 enabled
Kernel crashdump is disabled.
Resources folder check done!
Mfg. Backup Infra is Factory Disabled
dma_mem_base: 0x96000000, dma_mem_len: 0x8000000, warm_mem_base: 0xdf500000, warm_mem_len: 0xb00000
Creating TUN device
Enabling time stamp.
Starting the FastIron.
USER=root
HOME=/
GCOV_PREFIX=/fast_iron
ethaddr=60:9c:9f:27:a4:df?
TERM=vt102
PATH=/sbin:/usr/sbin:/bin:/usr/bin
ip=10.20.70.41:10.70.6.26:10.20.70.1:255.255.255.128:SP:eth0:off
SHELL=/bin/sh
PWD=/
[sp-gpio]:sil_gpiochip_register: gpiochip registration
i2c-0  smbus          iproc-smb-1          SMBus adapter  3
i2c-1  smbus          iproc-smb-1          SMBus adapter  3
FIPS Disabled:PORT NOT DISABLED
platform type 73
OS>
Loaded Image SPR08080B7 from Pri Built on (UTC): Sat May 26 18:33:53 2018
Enabling Console Logging
  Upgrade from pre 8.0.80 image. Dual mode to VLAN config upgrade needed
Hotplugger Daemon Initialized ..
set_board_level: gi_board_type = 101
System is booting up in PE mode: Jumbo frame is enabled.
[ 59.864651] linux-kernel-bde: map phys range 0x48000000-0x48040000 to 0xb0c33000-0xb0c73000
[ 59.965154] linux-kernel-bde: map phys range 0x42000000-0x42040000 to 0xb0bf3000-0xb0c33000
[ 60.065406] linux-kernel-bde: map phys range 0x42040000-0x42080000 to 0xb0bb3000-0xb0bf3000
[ 60.318856] linux-kernel-bde: map phys range 0x88100000-0x90100000 to 0xa8bb3000-0xb0bb3000
DMA pool size: 134217728
      SOC unit 0 attached to PCI device BCM56548_A0
BCM848xx: u=0 p=50: init. Chip Rev = 01 Version = 01.09.01 Date = 02/17/2000 (MDIO)
BCM848xx: u=0 p=51: init. Chip Rev = 01 Version = 01.09.01 Date = 02/17/2000 (MDIO)
Setting the CMIC registers for the link scan
SOC unit 1 attached to PCI device BCM56548_A0
BCM848xx: u=1 p=42: init. Chip Rev = 01 Version = 01.09.01 Date = 02/17/2000 (MDIO)
BCM848xx: u=1 p=43: init. Chip Rev = 01 Version = 01.09.01 Date = 02/17/2000 (MDIO)
Setting the CMIC registers for the link scan
ICX7450: no XML license is presented. SAU option: 13-prem.
Firmware version from File: 2.1.0
Pre Parsing Config Data ...

PE Unit: No BCM L3 Initialization
sw_pp_device_map_init -> PE INIT
Warning: This operation would close all existing SSH connection.
PE Unit: Skipping CPU next Hop creation
PE Unit: Skipping create nextHop drop
PE Unit: Not initing Ingress interfaces ...
Upgrade from pre 8.0.80 image. Dual mode to VLAN config upgrade flag is reset
PE Unit: Skipping create nextHop drop
bootup in PE mode
bootup in PE mode, enable processing of tagged LLDP packets

Creating certificate, please wait...
```

## Campus Fabric Manual Configuration

### Manually Enabling and Configuring PE Units

```
SSL Client Certificate is successfully created
System initialization completed...console going online.
Copyright (c) 2017 Ruckus Wireless, Inc. All rights reserved.
UNIT 1: compiled on May 26 2018 at 11:28:37 labeled as SPR08080B7
(29716384 bytes) from Primary SPR08080B7.bin
  SW: Version 08.0.80B7T213
Compressed Boot-Monitor Image size = 786944, Version:10.1.12T215 (spz10112b001)
  Compiled on Wed Mar 28 07:01:00 2018

HW: Stackable ICX7450-48-HPOE
Internal USB: Serial #: 9900515110300009
  Vendor: ATP Electronics, Total size = 1919 MB
```

Information on each port and module in the unit is displayed.

```
=====
UNIT 1: SL 1: ICX7450-48P POE 48-port Management Module
  Serial #:CYR3347L01Z
  Software Package: ICX7450_L3_SOFT_PACKAGE (LID: eatIIJMnFGb)
  Current License: l3-prem
  P-ASIC 0: type B548, rev 01 Chip BCM56548_A0
=====
UNIT 1: SL 2: ICX7400-4X10GC 4-port 40G Module
  Serial #:CYW3323K01W
=====
UNIT 1: SL 3: ICX7400-1X40GQ 1-port 40G Module
  Serial #:CYX3347L08F
=====
UNIT 1: SL 4: ICX7400-1X40GQ 1-port 40G Module
  Serial #:CYX3328L1NC
=====
1000 MHz ARM processor ARMv7 88 MHz bus
8192 KB boot flash memory
2048 MB code flash memory
2048 MB DRAM
STACKID 1 system uptime is 1 minute(s) 20 second(s)
The system started at 23:56:11 GMT+00 Fri Jun 15 2018

The system : started=warm start reloaded=by "reload"
Bootup role: Port Extender (PE)
```



The following segment shows the new PE joining the CB. It is assigned SPX unit ID 17 because it matches the reserved configuration created previously on the CB. This overrides any suggested ID configured earlier on the provisional PE.

```
[PE]local-17@ICX7450-48P Router#
Power supply 1 detected.
Power supply 1 is up.

Power supply 2 detected.
Power supply 2 is up.
PoE: Stack unit 1 Power supply 2 with 748000 mwatts capacity is up
PoE Info: Adding new 54V capacity of 748000 mW, total capacity is 748000, total free capacity is 748000
PoE Info: PoE module 1 of Unit 1 on ports 1/1/1 to 1/1/48 detected. Initializing....
2000 log entries of PoE Event Trace Log Buffer is allocated on unit 1 for unit 1
PoE Event Trace Logging enabled for unit 1
```

After the PE joins the CB, an rconsole session to the CB is automatically established from the PE unit. The prompt changes to reflect the remote connection. If a login is required, use the same login ID and password as for the CB active controller.

```
Connecting to control-bridge 1 console... (Press Ctrl Shift - x to exit)
ICX7650-26Q Router>
```

For direct physical access to the PE console once it has been redirected to the active controller console of the CB, press CTRL-SHIFT-x. This returns the PE to local mode.

The following examples display the **show running-config** and **show interface brief** command output for PE 17. The examples show the configuration and local interfaces for PE 17. The commands are entered from the CB console, which has been redirected to the PE console.

```
[PE]rconsole-17@ ICX7450-48P Router# show running-config
Current configuration:
!
ver 08.0.80B7T213
!
spx pe-enable
spx unit 17
  pe-name finance
  module 1 icx7450-48p-poe-management-module
  module 2 icx7400-xgc-4port-40g-module
  module 3 icx7400-qsfp-lport-40g-module
  module 4 icx7400-qsfp-lport-40g-module
  spx-lag 17/2/1 to 17/2/2
  spx-lag 17/3/1 17/4/1
!
jumbo
!
End
```

```
[PE]rconsole-17@ICX7450-48P Router# show interface brief
```

Port	Link	State	Dupl	Speed	Trunk	Tag	Pvid	Pri	MAC	Name
17/1/1	Down	None	None	None	None	no	N/A	0	609c.9f2a.d460	
17/1/2	Down	None	None	None	None	no	N/A	0	609c.9f2a.d461	
17/1/3	Down	None	None	None	None	no	N/A	0	609c.9f2a.d462	
17/1/4	Down	None	None	None	None	no	N/A	0	609c.9f2a.d463	
17/1/5	Down	None	None	None	None	no	N/A	0	609c.9f2a.d464	
17/1/6	Down	None	None	None	None	no	N/A	0	609c.9f2a.d465	
17/1/7	Down	None	None	None	None	no	N/A	0	609c.9f2a.d466	
17/1/8	Down	None	None	None	None	no	N/A	0	609c.9f2a.d467	
17/1/9	Down	None	None	None	None	no	N/A	0	609c.9f2a.d468	
17/1/10	Down	None	None	None	None	no	N/A	0	609c.9f2a.d469	
17/1/11	Down	None	None	None	None	no	N/A	0	609c.9f2a.d46a	
17/1/12	Down	None	None	None	None	no	N/A	0	609c.9f2a.d46b	
17/1/13	Down	None	None	None	None	no	N/A	0	609c.9f2a.d46c	
17/1/14	Down	None	None	None	None	no	N/A	0	609c.9f2a.d46d	
17/1/15	Down	None	None	None	None	no	N/A	0	609c.9f2a.d46e	
17/1/16	Down	None	None	None	None	no	N/A	0	609c.9f2a.d46f	
17/1/17	Down	None	None	None	None	no	N/A	0	609c.9f2a.d470	
17/1/18	Down	None	None	None	None	no	N/A	0	609c.9f2a.d471	
17/1/19	Down	None	None	None	None	no	N/A	0	609c.9f2a.d472	

## Campus Fabric Manual Configuration

### Manually Enabling and Configuring PE Units

```
17/1/20    Down    None    None None None no N/A 0 609c.9f2a.d473
17/1/21    Down    None    None None None no N/A 0 609c.9f2a.d474
17/1/22    Down    None    None None None no N/A 0 609c.9f2a.d475
17/1/23    Down    None    None None None no N/A 0 609c.9f2a.d476
17/1/24    Down    None    None None None no N/A 0 609c.9f2a.d477
17/1/25    Down    None    None None None no N/A 0 609c.9f2a.d478
17/1/26    Down    None    None None None no N/A 0 609c.9f2a.d479
17/1/27    Down    None    None None None no N/A 0 609c.9f2a.d47a
17/1/28    Down    None    None None None no N/A 0 609c.9f2a.d47b
17/1/29    Down    None    None None None no N/A 0 609c.9f2a.d47c
17/1/30    Down    None    None None None no N/A 0 609c.9f2a.d47d
17/1/31    Down    None    None None None no N/A 0 609c.9f2a.d47e
17/1/32    Down    None    None None None no N/A 0 609c.9f2a.d47f
17/1/33    Down    None    None None None no N/A 0 609c.9f2a.d480
17/1/34    Down    None    None None None no N/A 0 609c.9f2a.d481
17/1/35    Down    None    None None None no N/A 0 609c.9f2a.d482
17/1/36    Down    None    None None None no N/A 0 609c.9f2a.d483
17/1/37    Down    None    None None None no N/A 0 609c.9f2a.d484
17/1/38    Down    None    None None None no N/A 0 609c.9f2a.d485
17/1/39    Down    None    None None None no N/A 0 609c.9f2a.d486
17/1/40    Down    None    None None None no N/A 0 609c.9f2a.d487
17/1/41    Down    None    None None None no N/A 0 609c.9f2a.d488
17/1/42    Down    None    None None None no N/A 0 609c.9f2a.d489
17/1/43    Down    None    None None None no N/A 0 609c.9f2a.d48a
17/1/44    Down    None    None None None no N/A 0 609c.9f2a.d48b
17/1/45    Down    None    None None None no N/A 0 609c.9f2a.d48c
17/1/46    Down    None    None None None no N/A 0 609c.9f2a.d48d
17/1/47    Down    None    None None None no N/A 0 609c.9f2a.d48e
17/1/48    Down    None    None None None no N/A 0 609c.9f2a.d48f
17/2/1     Up      n/a     Full 10G 1 no N/A 0 609c.9f2a.d491
17/2/2     Up      n/a     Full 10G 1 no N/A 0 609c.9f2a.d492
17/2/3     Down    None    None None None no N/A 0 609c.9f2a.d493
17/2/4     Down    None    None None None no N/A 0 609c.9f2a.d494
17/3/1     Up      n/a     Full 40G 2 no N/A 0 609c.9f2a.d495
17/4/1     Up      n/a     Full 40G 2 no N/A 0 609c.9f2a.d499
lg1        Up      Forward Full 20G 1 No 1 0 609c.9f2a.d491
lg2        Up      Forward Full 80G 2 No 1 0 609c.9f2a.d495
mgmt1      Up      None    Full 1G  None No None 0 609c.9f2a.d460
[PE]rconsole-17@ICX7450-48P Router#
```

## SPX Port and LAG Configuration Rules

Unlike a stacking unit that has two factory default ports, PE units do not have predetermined default ports. However, a PE cannot join a CB without an SPX port or LAG running LLDP. SPX ports and LAGs are either configured by the user as part of a reserve configuration stored on the CB, or the system learns the port and LAG configuration from the PE unit when the PE joins the Campus Fabric domain.

The following rules apply if the reserve PE configuration on the CB differs from the PE configuration learned from the PE unit:

- If the reserve configuration contains no SPX port or LAG, the CB learns the SPX port and LAG configuration from the PE unit.
- If the reserve configuration on the CB contains SPX ports or LAGs, the CB pushes its SPX port and LAG configuration to the PE unit, after first checking that the PE unit will still be reachable once the configuration changes.

### NOTE

PE units further downstream are not guaranteed to remain reachable after the reserve configuration is pushed to the PE unit.

When the **spx pe-enable** command is entered locally on an ICX 7150, ICX 7250, or ICX 7450, the system generates two SPX ports as part of configuring the device as a provisional PE unit. The system applies the following rules to generate the SPX ports, based on the modules installed in the unit. The first rule has priority over the second rule.

1. If an ICX 7450 has any 4 X 10-Gbps ports, the system generates SPX port 1/x/1 and SPX port 1/x/3, where "x" is the slot number of the 4 X 10-Gbps module. If there are multiple 4 X 10-Gbps modules, the SPX ports are configured in the slot with the lowest number.
2. If an ICX 7450 has any 40-Gbps modules, the system designates up to two 40-Gbps ports as SPX ports.

3. If no 4 X 10-Gbps or 40-Gbps modules are present in the ICX 7450, the system does not generate any SPX ports for the unit.

The user can change the system-generated SPX ports locally while the PE is in Provisional-PE mode.

## Configuration Changes in PE Mode Before Joining the CB

When the system reboots after you save and reload a Provisional-PE configuration on an ICX 7150, ICX 7250, or ICX 7450 unit, the unit changes from Provisional-PE mode to PE mode. The change in status is visible in the device prompt.

The prefix [Provisional-PE] appears in front of the device prompt for a provisional PE.

```
[Provisional-PE]ICX7450-48F Router# reload
```

The prefix [PE] appears in front of the device prompt when the device enters PE mode.

```
[PE]ICX7450-48F Router#
```

When a PE is not part of a CB, you can still make and save SPX configuration changes.

### NOTE

When a PE loses its CB, it displays the following message, and you can again enter PE configuration mode:

```
T=5m21.2: Spx unit 19 is no longer managed by CB u2 (reason=uplink down).
```

### NOTE

When a unit boots in PE mode but is not yet attached to the CB, all non-SPX ports on the PE are down, but SPX ports are up. When a PE unit loses its CB, all non-SPX ports on the PE are brought down.

When the PE unit joins a CB, it automatically forms a remote console connection to the CB. The prompt changes to reflect the remote connection. Once a PE has successfully connected to the CB console, you can use the PE unit to manage the Campus Fabric network.

```
[PE]rconsole-17@ICX7450-48F Router#
```

## Regular, Provisional-PE, and PE Mode

In regular mode, a standalone ICX 7150, ICX 7250, or ICX 7450 unit behaves like a normal routing or switching device. In Provisional-PE or PE mode, the device operates differently and has different commands available to it.

### Provisional-PE Mode

Provisional-PE mode allows a regular ICX 7150, ICX 7250, or ICX 7450 router to configure PE mode without affecting any router configuration. Typically, a unit boots up in regular mode and operates like a regular device. An ICX 7150, ICX 7250, or ICX 7450 unit enters Provisional-PE mode after the user configures the **spx pe-enable** command but has not reloaded the unit. The unit still acts like a regular switch or router. Most commands, including configuration commands, are blocked as they are in PE mode.

A unit in Provisional-PE mode cannot send or receive stacking packets such as topology probes. It cannot perform secure setup or unit replacement.

A unit in Provisional-PE mode has the same user interfaces as a unit in PE mode. For example, a unit in Provisional-PE mode still does MAC learning or runs OSPF protocols; however, the user cannot execute the **show mac** or **show ip route** commands. The **show running-config** command shows the PE configuration only.

A unit in Provisional-PE mode can enter regular mode immediately when the **no spx pe-enable** command is entered. Any previous runtime configuration is restored as if nothing has happened. The **show running-config** command shows the restored configuration.

When a unit enters Provisional-PE mode the first time, the **show running-config** command displays the unit as spx unit 1 with the default configuration. The user can execute the **spx-port**, **spx-lag**, and **pe-name** commands. Changing from regular mode to Provisional-PE mode after the first time restores the previous PE configuration.

## PE Mode

A unit boots up in PE mode and operates as a dummy device. It does not parse the startup-config file when it boots up. The unit runs protocols, such as LLDP, available to a PE unit. It does not perform local switching. Most commands, including configuration commands, are blocked.

After a PE receives its assigned ID, it cannot run the **configure terminal** command. If the unit is in configuration mode, it exits configuration mode. The **configure terminal** command is unblocked when the PE unit is no longer joined to a CB. This state is indicated by an "spx-port/lag down" status or by CB keep-alive aging.

The runtime configuration displayed by the **show running-config** command differs in regular mode and PE mode. The **show running-config** command shows the PE configuration only.

### NOTE

A unit in regular mode can never reload to PE mode, for example, after you execute a reload or after a power failure occurs. Only Provisional-PE mode can reload a unit to PE mode.

PE mode cannot change to Provisional-PE mode or regular mode. There are several ways to recover a PE unit to regular mode:

- If the PE is not managed by the CB, disable SPX with the **no spx-enable** command and then enter the **write memory** command followed by the **reload** command.
- If the PE is managed by the CB, on the CB, enter the **spx unconfigure unit-id id** command to reload the PE to standalone mode. Here, *id* is the PE ID for the unit.
- If a group of PEs is managed by the CB, on the CB, enter the **spx unconfigure unit-id id** command and specify a range of IDs, a series, or both. Use no spaces in the ID string. For example, **spx unconfigure unit-id 23-27,30,35,40-43** returns PE units 23, 24, 25, 26, 27, 30, 35, 40, 41, 42, and 43 to regular mode.
- Issue the **spx unconfigure me** command on the PE unit.

### NOTE

Starting with release 08.0.80, when a PE joins a SPX system, its local console automatically executes an **rconsole** to the CB. This is reflected in the device prompt (for example, rconsole-17@ICX7450-48F Router#). When a PE unit has been successfully redirected to the CB, you can manage the Campus Fabric from the PE unit if necessary. If the PE loses connection to the CB, it returns to the PE unit's local console. The PE unit's local console has limited configuration and reload capabilities as shown in the following table.

## Unit Operating Mode Comparison

The following table describes differences in capabilities for an ICX 7150, ICX 7250, or ICX 7450 unit in regular, Provisional-PE, and PE modes.

**TABLE 9** Differences in Operating Modes

Prompt or Command	Regular Mode	Provisional-PE Mode	PE Mode
Device prompt	Device_type-role# For example, ICX7450-48F Router#	[Provisional-PE]ICX7450-48F Router#	[PE]ICX7450-48F Router#

**TABLE 9** Differences in Operating Modes (continued)

Prompt or Command	Regular Mode	Provisional-PE Mode	PE Mode
Commands available	All permitted commands are available, including stacking commands when stacking is enabled.	These commands are available: <b>configure terminal</b> , SPX unit configuration options, <b>write memory</b> , <b>reload</b> , <b>spx unconfigure</b> , <b>show configuration</b> , and <b>show startup-config</b> .	When a PE joins an SPX system, its local console is automatically redirected to the CB console. These commands are available only if a PE is not managed by the CB (you must press CTRL-Shift-X to exit the CB console): <b>configure terminal</b> , SPX unit configuration options, <b>write memory</b> , <b>reload</b> , <b>spx unconfigure</b> , <b>show configuration</b> , and <b>show startup-config</b> .
<b>write memory</b>	The <b>write memory</b> command writes to the startup configuration file for regular mode. If this unit has any attached PE units, it sends a message to all of them to write to the PE startup file.	The <b>write memory</b> command writes to the PE startup file. It gives a warning message if the configuration contains no SPX ports or SPX LAGs.	The <b>write memory</b> command writes to the PE startup file if the PE unit has not joined a CB. Once the PE unit joins a CB, the <b>write memory</b> command is blocked. When the CB executes the <b>write memory</b> command, the PE unit writes to the PE startup file.

**TABLE 9** Differences in Operating Modes (continued)

Prompt or Command	Regular Mode	Provisional-PE Mode	PE Mode
<b>reload</b>	In regular mode, the switch or router can only reload to switch or router mode. A reload can occur intentionally when the user enters the <b>reload</b> command, or unintentionally, for example, following a power drop.	<p>A provisional PE can only reload PE mode. When the <b>reload</b> command is executed on a provisional PE, the system does two things:</p> <ol style="list-style-type: none"> <li>1. It checks whether the PE startup file has <b>spx pe-enable</b> configured. If the file does not exist or <b>spx pe-enable</b> is not configured in the file, the system blocks the command:   <b>[Provisional-PE]ICX7450-48F            Router# reload</b>   <pre>Error! provisional PE can only reload to PE mode, but boot file has no "spx pe- enable".  Please do "write memory" and try again, or "no spx pe-enable" to go back to switch/ router mode.</pre> </li> <li>2. It compares the current configuration and the startup file. If they are different, the system prints the following message:   <b>[Provisional-PE]ICX7450-48F            Router# reload</b>   <pre>Are you sure? (enter 'y' or 'n'): y  Running Config data has been changed. Do you want to continue the reload without saving the running config? (enter 'y' or 'n'): n  Please save the running config and try reload again</pre> </li> </ol> <p>If you change the device back to router mode with the <b>no spx pe-enable</b> command, the system immediately removes the <b>spx pe-enable</b> configuration from the PE startup file. Other contents in the file are kept. This is to prevent a router from accidentally reloading as a PE.</p>	<p>A unit in PE mode can reload to PE mode or router mode depending whether it has <b>spx pe-enable</b> configured in the PE startup file. There are two ways to reload a PE to switch or router mode locally from the console of a PE not controlled by a CB:</p> <ol style="list-style-type: none"> <li>1. After removing the <b>spx pe-enable</b> configuration in PE mode, the user can execute the <b>write memory</b> command and then the <b>reload</b> command. The system still retains the PE startup file, which contains other information, such as the SPX port and LAG configuration. If the user wants to change from router mode to Provisional-PE mode by entering the <b>spx pe-enable</b> command, all the SPX port and LAG configuration is restored.</li> <li>2. The <b>spx unconfigure</b> command can be entered from the CB or the PE unit to remove the PE startup file and reload the PE unit as a router. The command removes all SPX port and LAG information.</li> </ol>
<b>rconsole</b>	The <b>rconsole</b> command can be used to access a PE unit. (Not applicable for a standalone unit.)	The <b>rconsole</b> command is not available.	When a PE joins an SPX system, its console is re-directed to the CB. When a PE loses the CB, its console returns to local. From the redirected CB console, the <b>rconsole</b> command can be used to access the local PE console.

**TABLE 9** Differences in Operating Modes (continued)

Prompt or Command	Regular Mode	Provisional-PE Mode	PE Mode
<b>show configuration</b>	The <b>show configuration</b> command shows the startup-configuration file used in regular mode bootup.	The <b>show configuration</b> command shows the PE startup file used in PE mode bootup.	The <b>show configuration</b> command shows the PE startup file used in PE mode bootup.
<b>show running-config</b>	The <b>show running-config</b> command shows the current running configuration.	The <b>show running-config</b> command shows the running configuration the unit would have if it were reloaded and operating in PE mode.	The <b>show running-config</b> command shows the current running configuration.
<b>show startup-configuration</b>	Command not available.	The <b>show startup-configuration</b> command shows the startup-configuration file used in regular mode bootup.	The <b>show startup-configuration</b> command shows the startup-configuration file used in regular mode bootup.
<b>spx unconfigure me</b>	The <b>spx unconfigure</b> command can be used from the CB to unconfigure a PE unit; however, <b>spx unconfigure me</b> is not available from the CB.	The <b>spx unconfigure me</b> command removes the PE startup file, but the unit does not reload.	The <b>spx unconfigure me</b> command removes the PE startup file. The user is prompted to confirm the command before it is run. The command removes the PE startup file and reloads the unit as a standalone device.

## Dynamic Versus Static SPX Configuration

A static PE unit has saved configuration in startup configuration flash. The PE unit continues to exist if the system reloads. A PE unit with dynamic configuration does not have its configuration stored in startup flash. Consequently, the dynamically configured PE configuration is removed when the system reloads.

For example, when PE 18 joins a CB and the CB does not have a reserved configuration for SPX unit 18, the CB generates a new configuration. The PE is a dynamic PE unit until the configuration is saved to startup flash. If SPX unit 18 leaves the system before its configuration is saved, the CB removes SPX unit 18 configuration.

You can change the configuration of an SPX port or LAG for a dynamically learned PE unit. The system changes the unit from dynamic to static. If the PE unit leaves the Campus Fabric domain, the system retains the static configuration. When you change the configuration of a dynamic unit (that is, a unit whose configuration has not been saved to startup flash), the system keeps your changes as part of the dynamic configuration. As a result, if the PE unit leaves and rejoins the Campus Fabric domain, you do not need to modify the configuration again. A static configuration is retained when the unit leaves the domain; however, it may still be lost after a reload if you have not saved it by using the **write memory** command.

In Provisional-PE mode or in PE mode before the unit joins a CB, you can enter the **write memory** command to save the configuration as a static configuration in the PE startup file. Once the PE unit has joined a CB, the **write memory** command can be entered only from the CB. When the CB runs the **write memory** command, it sends a message to the PE unit that causes it to save the configuration in the PE startup file.

The **show spx** command identifies static ("S") and dynamic ("D") PE units. If a dynamic PE unit leaves the Campus Fabric domain, the unit is no longer present in command output. In contrast, if a PE unit with a static configuration leaves the domain, its configuration is still displayed in **show spx** command output, and its status is indicated as "Reserve." The following example shows one reserved PE configuration that has previously been saved (unit 17) and one dynamic PE unit (unit 18).

```
ICX7750-26Q Router# show spx
T=3h16m53.6: alone: standalone, D: dynamic cfg, S: static
ID  Type          Role      Mac Address  Pri  State  Comment
 1  S ICX7750-26QXG active    cc4e.2438.7280 0  local  Ready
 2  S ICX7750-26QXG member    0000.0000.0000 0  reserve
 3  S ICX7750-26QXG standby  748e.f8f9.6300 0  remote Ready
17  S ICX7450-24G   spx      0000.0000.0000 0  reserve
18  D ICX7750-26QXG spx      cc4e.2438.7500 0  remote Ready
active standby
+---+         +---+
| 1 |2/4--2/1| 3 |
+---+         +---+
                   +-----+
1/2/1--2/4| 18 |1/10=
                   +-----+
```

## Campus Fabric Detailed Manual Configuration Example

The following examples show the configuration steps performed from the CB and the PE, detailing how the PE transitions between modes, and the output displayed when the PE joins a CB.

### CB Configuration

The following example shows a CB and PE unit configuration. The first segment shows the running configuration, including a stack of two ICX 7750 units.

```
ICX7750-26Q Router> en
!
ICX7750-26Q Router# show running-config
Current configuration:
!
ver 08.0.80b1T203
!
stack unit 1
  module 1 icx7750-20-qxg-port-management-module
  module 2 icx7750-qsfp-6port-qsfp-240g-module
  module 3 icx7750-6q-6port-qsfp-240g-module
  stack-port 1/2/4
stack unit 2
  module 1 icx7750-20-qxg-port-management-module
  module 2 icx7750-qsfp-6port-qsfp-240g-module
  module 3 icx7750-6q-6port-qsfp-240g-module
  stack-port 2/2/4
stack enable
stack mac cc4e.2438.7280
!
!
```

The following segment shows available options for SPX in configuration mode on the ICX 7750 core stack (the CB).

```
ICX7750-26Q Router# configure terminal
ICX7750-26Q Router(config)# spx ?
  allow-pe-movement  A PE keeps its ID when moves
  cb-configure       802.lbr Control Bridge Configuration: spx-port, spx-lag
  cb-enable         enable CB mode
  unit              configure a pe unit
```

The following segment creates a reserved configuration for SPX unit 18 and then checks the configuration with the **show running-config** command. The reserved configuration for SPX unit 18 appears below the stack unit configuration. No SPX ports are generated automatically for a reserved SPX configuration created on the CB.

```
ICX7750-26Q Router(config)# spx unit 18
ICX7750-26Q Router(config-spx-unit-18)# pe-name bldg2-floor2-stk18
ICX7750-26Q Router(config-spx-unit-18)# module 1 icx7450-48f-sf-port-management-module
ICX7750-26Q Router(config-spx-unit-18)# module 2 icx7400-xgf-4port-40g-module
ICX7750-26Q Router(config-spx-unit-18)# module 4 icx7400-qsfp-1port-40g-module
ICX7750-26Q Router(config-spx-unit-18)# show running-config
Current configuration:
!
ver 08.0.80b1T203
!
spx cb-enable
stack unit 1
  module 1 icx7750-20-qxg-port-management-module
  module 2 icx7750-qsfp-6port-qsfp-240g-module
  module 3 icx7750-6q-6port-qsfp-240g-module
  stack-port 1/2/4
stack unit 2
  module 1 icx7750-20-qxg-port-management-module
  module 2 icx7750-qsfp-6port-qsfp-240g-module
```



```

module 3 icx7750-6q-6port-qsfp-240g-module
stack-port 2/2/4
spx unit 18
pe-name bldg2-floor2-stk18
module 1 icx7450-48f-sf-port-management-module
module 2 icx7400-xgf-4port-40g-module
module 4 icx7400-qsfp-1port-40g-module
stack enable
stack mac cc4e.2438.7280
!
```

The following segment shows optional user configuration of an SPX port and an SPX LAG, which is added to the reserved configuration for SPX unit 18. This configuration will be pushed to a PE unit that is assigned this ID when it joins the CB, as long as the new SPX ports do not make the PE unit inaccessible from the CB. In this case, the configuration is accepted as shown in **show running-config** output.

```

ICX7750-26Q Router(config-spx-unit-21)# spx-port 18/2/4
ICX7750-26Q Router(config-spx-unit-21)# spx-lag 18/1/10 to 18/1/11
ICX7750-26Q Router(config-spx-unit-21)# exit
ICX7750-26Q Router(config)# show running-config
Current configuration:
!
!
spx unit 18
pe-name bldg2-floor2-stk18
module 1 icx7450-48f-sf-port-management-module
module 2 icx7400-xgf-4port-40g-module
module 4 icx7400-qsfp-1port-40g-module
spx-lag 18/1/10 to 18/1/11
spx-port 18/2/4
```

The following segment configures the CB. SPX ports and SPX LAGs are created on the CB. Optional PE group names are applied. The group names can be referenced to assign PE IDs from the CB when desired, and they appear in SPX **show** command output.

```

ICX7750-26Q Router(config)# spx cb-config
ICX7750-26Q Router(config-spx-cb)# spx-port 1/1/5 pe-group bld1-fl2-stk5
ICX7750-26Q Router(config-spx-cb)# spx-port 1/1/6
ICX7750-26Q Router(config-spx-cb)# spx-lag 1/1/10 to 1/1/11 pe-group bld1-fl3-stk7
ICX7750-26Q Router(config-spx-cb)# spx-port 1/2/1 pe-group stk_HR
ICX7750-26Q Router(config-spx-cb)# exit
```

The following segment reserves PE ID 18 for a PE that joins on SPX port 1/2/1. It also reserves PE ID 20 for a PE unit that joins on the SPX LAG configured in the previous segment. Notice that a port number is used in the first case, but the PE group name is used to represent the SPX LAG on which the PE ID of 20 is reserved. The PE group name, the individual SPX port number, or any port in an SPX LAG can be used to represent the same PE ID assignment.

```

ICX7750-26Q Router(config-spx-cb)# pe-id 1/2/1 18
!
ICX7750-26Q Router(config-spx-cb)# pe-id bld1-fl3-stk7 20
!
ICX7750-26Q Router(config-spx-cb)# show running-config
Current configuration:
<snip>

spx unit 18
pe-name bldg2-floor2-stk18
module 1 icx7450-48f-sf-port-management-module
module 2 icx7400-xgf-4port-40g-module
module 4 icx7400-qsfp-1port-40g-module
spx-lag 18/1/10 to 18/1/11
spx-port 18/2/4

stack enable
stack mac cc4e.2438.7280
!
spx cb-enable
spx cb-config
spx-port 1/1/5 pe-group bld1-fl2-stk5
spx-port 1/1/6
```

## Campus Fabric Manual Configuration

### Campus Fabric Detailed Manual Configuration Example

```
spx-lag 1/1/10 to 1/1/11 pe-group bld1-fl3-stk7
spx-port 1/2/1 pe-group stk_HR
pe-id stk_HR 18
pe-id bld1-fl3-stk7 20
```

If a PE unit matching the reserved configuration for SPX unit 18 were to join a CB unit, the following information would be displayed.

```
ICX7750-26Q Router#T=2m27.1: create spx u18, PE-port=18/2/4, CB-port=1/2/1 mac=cc4e.2438.7500, has
provisional config
```

```
ICX7750-26Q Router#
ICX7750-26Q Router#T=2m27.5: U1 hotswap spx u18
```

The **show spx** command entered on the CB displays information similar to the following example.

```
ICX7750-26Q Router# show spx
T=3m6.7: alone: standalone, D: dynamic cfg, S: static
ID  Type          Role      Mac Address      Pri State  Comment
1   S ICX7750-26QXG active  cc4e.2438.7280   0 local  Ready
2   S ICX7750-26QXG standby 748e.f8f9.6300   0 remote Ready
18  S ICX7450-48GF spx-pe   cc4e.2438.7500  N/A remote Ready  <-- Reserved configuration
                                     has been applied, and
                                     PE unit 18 is operational.
```

```
active          standby
+----+         +----+
| 1 |2/4--2/1| 2 |
+----+         +----+
```

```
1/2/1 pe-group bldg1-name3
+-----+
1/2/1--2/4| 18 |1/10=
+-----+
```

## PE Configuration

The following example converts an ICX 7450 standalone unit to a PE unit. If stacking is enabled, it must be disabled before the unit can be enabled as a PE.

```
ICX7450-48P Router# configure terminal
ICX7450-48P Router(config)# spx ?
  pe-enable          enable PE mode
  zero-touch-deny    cannot be discovered
ICX7450-48P Router(config)# spx pe-enable
Enter provisional PE mode. CLI is limited to spx unit 1.
After finishing all configuration, please "write memory" and reload this unit to be a PE.
[Provisional-PE]ICX7450-48P Router(config)# show running-config
Current configuration:
!
ver 08.0.80B7T213
!
spx pe-enable
spx unit 1
  module 1 icx7450-48p-poe-management-module
  module 2 icx7400-xgc-4port-40g-module
  module 3 icx7400-qsfp-1port-40g-module
  module 4 icx7400-qsfp-1port-40g-module
  spx-port 1/2/1          |<-- system generates spx-port 1/2/1 and 1/2/3 if module 2 is 4x10G.
  spx-port 1/2/3          |<--
!
End
```

The following segment creates a suggested ID for the new PE unit, which has entered Provisional-PE mode as indicated in the prefix of the command line prompt. The PE ID can be overridden by other configuration information on the CB.

```
[Provisional-PE]ICX7450-48P Router(config)# spx suggested-id 20
[Provisional-PE]ICX7450-48P Router(config)# show running-config
Current configuration:
!
ver 08.0.80B7T213
!
spx pe-enable
spx suggested-id 20
spx unit 1
  module 1 icx7450-48p-poe-management-module
  module 2 icx7400-xgc-4port-40g-module
  module 3 icx7400-qsfp-1port-40g-module
  module 4 icx7400-qsfp-1port-40g-module
  spx-port 1/2/1
  spx-port 1/2/3
!
End
```

The following segment shows optional SPX port and SPX LAG configuration and confirms the running configuration.

```
[Provisional-PE]ICX7450-48P Router(config)# spx unit 1
[Provisional-PE]ICX7450-48P Router(config-spx-unit-1)# spx-lag 1/2/1 to 1/2/2
spx-port 1/2/1 is replaced by spx-lag 1/2/1 to 1/2/2
[Provisional-PE]ICX7450-48P Router(config-spx-unit-1)# no spx-port 1/2/3
spx-port 1/2/3 is removed.
[Provisional-PE]ICX7450-48P Router(config-spx-unit-1)# spx-port 1/2/4
spx-port 1/2/3 is replaced by spx-port 1/3/1 |<-- system generates spx-port
1/3/1 after 1/2/3 is removed.
[Provisional-PE]ICX7450-48P Router(config-spx-unit-1)# show running-config
Current configuration:
!
ver 08.0.80B7T213
!
spx pe-enable
spx suggested-id 20
spx unit 1
  module 1 icx7450-48p-poe-management-module
  module 2 icx7400-xgc-4port-40g-module
  module 3 icx7400-qsfp-1port-40g-module
  module 4 icx7400-qsfp-1port-40g-module
  spx-lag 1/2/1 to 1/2/2
  spx-port 1/2/4
  spx-port 1/3/1
!
```

The following segment saves the configuration in the SPX boot file and confirms its contents.

```
[Provisional-PE]ICX7450-48P Router# write memory
[Provisional-PE]ICX7450-48P Router(config-spx-unit-1)# show config
Configuration in spx_pe.boot:
!
ver 08.0.80B7T213
!
spx pe-enable
spx suggested-id 20
spx unit 1
  module 1 icx7450-48p-poe-management-module
  module 2 icx7400-xgc-4port-40g-module
  module 3 icx7400-qsfp-1port-40g-module
  module 4 icx7400-qsfp-1port-40g-module
  spx-lag 1/2/1 to 1/2/2
  spx-port 1/2/4
  spx-port 1/3/1
!
```

## Campus Fabric Manual Configuration

### Campus Fabric Detailed Manual Configuration Example

The following segment reloads the ICX 7450, which moves from Provisional-PE to PE mode after the reload.

```
[Provisional-PE]ICX7450-48P Router# reload
Are you sure? (enter 'y' or 'n'): y
Unmounting the External USB
We are in system resetDisabled core-1
CPU Sampling disabled.
The system is going down NOW!!!

!
Ruckus Wireless Bootloader: 10.1.12b001T215 (Mar 28 2018 - 00:00:53)

Validate Shmoo parameters stored in flash ..... OK
Restoring Shmoo parameters from flash .....
Running simple memory test ..... OK
  ICX7450-48 Copper (POE), PVT1
SYS CPLD VER: 0x10, Released Ver: 0

Enter 'b' to stop at boot monitor: 0
bootdelay: ===
Booting image from Primary
.....
.....
...## Booting kernel from FIT Image at 70000200 ...
  Using 'conf@2' configuration
  Trying 'kernel@1' kernel subimage
    Description: Ruckus Linux SP/SI
    Type: Kernel Image
    Compression: lzma compressed
    Data Start: 0x700002d0
    Data Size: 2178385 Bytes = Architecture: ARM
    OS: Linux
    Load Address: 0x61008000
    Entry Point: 0x61008000
    Hash algo: crc32
    Hash value: fa26f214
  Verifying Hash Integrity ... crc32+ OK
## Loading init Ramdisk from FIT Image at 70000200 ...
  Using 'conf@2' configuration
  Trying 'ramdisk@1' ramdisk subimage
    Description: Ramdisk -rootfs
    Type: RAMDisk Image
    Compression: lzma compressed
    Data Start: 0x70430060
    Data Size: 25319571 Bytes = Architecture: ARM
    OS: Linux
    Load Address: 0x00000000
    Entry Point: 0x00000000
    Hash algo: crc32
    Hash value: 4acb6356
  Verifying Hash Integrity ... crc32+ OK
## Flattened Device Tree from FIT Image at 70000200
  Using 'conf@2' configuration
  Trying 'fdt@1' FDT blob subimage
    Description: Flattened Device Tree blob
    Type: Flat Device Tree
    Compression: uncompressed
    Data Start: 0x70429790
    Data Size: 8922 Bytes = Architecture: ARM
    Hash algo: crc32
    Hash value: 10a00dea
  Verifying Hash Integrity ... crc32+ OK
  Loading FDT from 0x70429790 to 0x65008000
  Booting using the fdt blob at 0x65008000
  Uncompressing Kernel Image ... OK
  Using Device Tree in place at 65008000, end 6500d2d9

Starting kernel ...

bcmiproc-gmac 18023000.ethernet: can't find MAC address
```

```
booting with 4.4 kernel
PLATFORM SP
SP's eUSB-Infra Called
  Number of eUSB partitions 3 ...
PLATFORM SP
Config partition mounted.
eUSB flash drive is ready No External USB Drive(s) Mounted . Enabling core#1
core#1 enabled
Kernel crashdump is disabled.
Resources folder check done!
Mfg. Backup Infra is Factory Disabled
dma_mem_base: 0x96000000, dma_mem_len: 0x8000000, warm_mem_base: 0xdf500000, warm_mem_len: 0xb00000
Creating TUN device
Enabling time stamp.
Starting the FastIron.
USER=root
HOME=/
GCOV_PREFIX=/fast_iron
ethaddr=60:9c:9f:27:a4:df?
TERM=vt102
PATH=/sbin:/usr/sbin:/bin:/usr/bin
ip=10.20.70.41:10.70.6.26:10.20.70.1:255.255.255.128:SP:eth0:off
SHELL=/bin/sh
PWD=/
[sp-gpio]:sil_gpiochip_register: gpiochip registration
i2c-0  smbus          iproc-smb-1          SMBus adapter  3
i2c-1  smbus          iproc-smb-1          SMBus adapter  3
FIPS Disabled:PORT NOT DISABLED
platform type 73
OS>
Loaded Image SPR08080B7 from Pri Built on (UTC): Sat May 26 18:33:53 2018
Enabling Console Logging
  Upgrade from pre 8.0.80 image. Dual mode to VLAN config upgrade needed
Hotplugger Daemon Initialized ..
set_board_level: gi_board_type = 101
System is booting up in PE mode: Jumbo frame is enabled.
[ 59.864651] linux-kernel-bde: map phys range 0x48000000-0x48040000 to 0xb0c33000-0xb0c73000
[ 59.965154] linux-kernel-bde: map phys range 0x42000000-0x42040000 to 0xb0bf3000-0xb0c33000
[ 60.065406] linux-kernel-bde: map phys range 0x42040000-0x42080000 to 0xb0bb3000-0xb0bf3000
[ 60.318856] linux-kernel-bde: map phys range 0x88100000-0x90100000 to 0xa8bb3000-0xb0bb3000
DMA pool size: 134217728
  SOC unit 0 attached to PCI device BCM56548_A0
BCM848xx: u=0 p=50: init. Chip Rev = 01 Version = 01.09.01 Date = 02/17/2000 (MDIO)
BCM848xx: u=0 p=51: init. Chip Rev = 01 Version = 01.09.01 Date = 02/17/2000 (MDIO)
Setting the CMIC registers for the link scan
SOC unit 1 attached to PCI device BCM56548_A0
BCM848xx: u=1 p=42: init. Chip Rev = 01 Version = 01.09.01 Date = 02/17/2000 (MDIO)
BCM848xx: u=1 p=43: init. Chip Rev = 01 Version = 01.09.01 Date = 02/17/2000 (MDIO)
Setting the CMIC registers for the link scan
ICX7450: no XML license is presented. SAU option: 13-prem.
Firmware version from File: 2.1.0
Pre Parsing Config Data ...

PE Unit: No BCM L3 Initialization
sw_pp_device_map_init -> PE INIT
Warning: This operation would close all existing SSH connection.
PE Unit: Skipping CPU next Hop creation
PE Unit: Skipping create nextHop drop
PE Unit: Not initing Ingress interfaces ...
Upgrade from pre 8.0.80 image. Dual mode to VLAN config upgrade flag is reset
PE Unit: Skipping create nextHop drop
bootup in PE mode
bootup in PE mode, enable processing of tagged LLDP packets

Creating certificate, please wait...

SSL Client Certificate is successfully created
System initialization completed...console going online.
Copyright (c) 2017 Ruckus Wireless, Inc. All rights reserved.
UNIT 1: compiled on May 26 2018 at 11:28:37 labeled as SPR08080B7
(29716384 bytes) from Primary SPR08080B7.bin
```

## Campus Fabric Manual Configuration

### Campus Fabric Detailed Manual Configuration Example

```
SW: Version 08.0.80B7T213
Compressed Boot-Monitor Image size = 786944, Version:10.1.12T215 (spz10112b001)
Compiled on Wed Mar 28 07:01:00 2018

HW: Stackable ICX7450-48-HPOE
Internal USB: Serial #: 9900515110300009
Vendor: ATP Electronics, Total size = 1919 MB
=====
UNIT 1: SL 1: ICX7450-48P POE 48-port Management Module
Serial #:CYR3347L01Z
Software Package: ICX7450_L3_SOFT_PACKAGE (LID: eatIIJmFGb)
Current License: l3-prem
P-ASIC 0: type B548, rev 01 Chip BCM56548_A0
=====
UNIT 1: SL 2: ICX7400-4X10GC 4-port 40G Module
Serial #:CYW3323K01W
=====
UNIT 1: SL 3: ICX7400-1X40GQ 1-port 40G Module
Serial #:CYX3347L08F
=====
UNIT 1: SL 4: ICX7400-1X40GQ 1-port 40G Module
Serial #:CYX3328L1NC
=====
1000 MHz ARM processor ARMv7 88 MHz bus
8192 KB boot flash memory
2048 MB code flash memory
2048 MB DRAM
STACKID 1 system uptime is 1 minute(s) 20 second(s)
The system started at 23:56:11 GMT+00 Fri Jun 15 2018

The system : started=warm start reloaded=by "reload"
Bootup role: Port Extender (PE)
```

The following segment shows the new PE joining the CB. It is assigned SPX unit ID 17 because it matches the reserved configuration created previously on the CB. This overrides any suggested ID configured earlier on the provisional PE.

```
[PE]local-17@ICX7450-48P Router#
Power supply 1 detected.
Power supply 1 is up.

Power supply 2 detected.
Power supply 2 is up.
PoE: Stack unit 1 Power supply 2 with 748000 mwatts capacity is up
PoE Info: Adding new 54V capacity of 748000 mW, total capacity is 748000, total free capacity is 748000
PoE Info: PoE module 1 of Unit 1 on ports 1/1/1 to 1/1/48 detected. Initializing...
2000 log entries of PoE Event Trace Log Buffer is allocated on unit 1 for unit 1
PoE Event Trace Logging enabled for unit 1
```

After the PE joins the CB, an rconsole session to the CB is automatically established from the PE unit. The prompt changes to reflect the remote connection. When the PE is redirected to the CB console, you can manage the Campus Fabric network from the PE if you prefer.

```
Connecting to control-bridge 1 console... (Press Ctrl Shift - x to exit)
ICX7750-26Q Router>

ICX7750-26Q Router> enable
No password has been assigned yet...
ICX7750-26Q Router# rconsole 17
Connecting to unit 17... (Press Ctrl-o x or type exit to exit)
[PE]rconsole-17@ICX7450-48P Router#
```

The following examples display the **show running-config** and **show interface brief** command output for PE 17. The example show the configuration and the local interfaces for PE 17. The commands are entered from the PE console, which has been redirected to the CB console.

```
[PE]rconsole-17@ ICX7450-48P Router #show running-config
Current configuration:
!
ver 08.0.80B7T213
!
spx pe-enable
```

```

spx unit 17
  pe-name finance
  module 1 icx7450-48p-poe-management-module
  module 2 icx7400-xgc-4port-40g-module
  module 3 icx7400-qsfp-1port-40g-module
  module 4 icx7400-qsfp-1port-40g-module
  spx-lag 17/2/1 to 17/2/2
  spx-lag 17/3/1 17/4/1
!
jumbo
!
End

```

[PE]rconsole-17@ICX7450-48P Router# show interface brief

Port	Link	State	Dupl	Speed	Trunk	Tag	Pvid	Pri	MAC	Name
17/1/1	Down	None	None	None	None	no	N/A	0	609c.9f2a.d460	
17/1/2	Down	None	None	None	None	no	N/A	0	609c.9f2a.d461	
17/1/3	Down	None	None	None	None	no	N/A	0	609c.9f2a.d462	
17/1/4	Down	None	None	None	None	no	N/A	0	609c.9f2a.d463	
17/1/5	Down	None	None	None	None	no	N/A	0	609c.9f2a.d464	
17/1/6	Down	None	None	None	None	no	N/A	0	609c.9f2a.d465	
17/1/7	Down	None	None	None	None	no	N/A	0	609c.9f2a.d466	
17/1/8	Down	None	None	None	None	no	N/A	0	609c.9f2a.d467	
17/1/9	Down	None	None	None	None	no	N/A	0	609c.9f2a.d468	
17/1/10	Down	None	None	None	None	no	N/A	0	609c.9f2a.d469	
17/1/11	Down	None	None	None	None	no	N/A	0	609c.9f2a.d46a	
17/1/12	Down	None	None	None	None	no	N/A	0	609c.9f2a.d46b	
17/1/13	Down	None	None	None	None	no	N/A	0	609c.9f2a.d46c	
17/1/14	Down	None	None	None	None	no	N/A	0	609c.9f2a.d46d	
17/1/15	Down	None	None	None	None	no	N/A	0	609c.9f2a.d46e	
17/1/16	Down	None	None	None	None	no	N/A	0	609c.9f2a.d46f	
17/1/17	Down	None	None	None	None	no	N/A	0	609c.9f2a.d470	
17/1/18	Down	None	None	None	None	no	N/A	0	609c.9f2a.d471	
17/1/19	Down	None	None	None	None	no	N/A	0	609c.9f2a.d472	
17/1/20	Down	None	None	None	None	no	N/A	0	609c.9f2a.d473	
17/1/21	Down	None	None	None	None	no	N/A	0	609c.9f2a.d474	
17/1/22	Down	None	None	None	None	no	N/A	0	609c.9f2a.d475	
17/1/23	Down	None	None	None	None	no	N/A	0	609c.9f2a.d476	
17/1/24	Down	None	None	None	None	no	N/A	0	609c.9f2a.d477	
17/1/25	Down	None	None	None	None	no	N/A	0	609c.9f2a.d478	
17/1/26	Down	None	None	None	None	no	N/A	0	609c.9f2a.d479	
17/1/27	Down	None	None	None	None	no	N/A	0	609c.9f2a.d47a	
17/1/28	Down	None	None	None	None	no	N/A	0	609c.9f2a.d47b	
17/1/29	Down	None	None	None	None	no	N/A	0	609c.9f2a.d47c	
17/1/30	Down	None	None	None	None	no	N/A	0	609c.9f2a.d47d	
17/1/31	Down	None	None	None	None	no	N/A	0	609c.9f2a.d47e	
17/1/32	Down	None	None	None	None	no	N/A	0	609c.9f2a.d47f	
17/1/33	Down	None	None	None	None	no	N/A	0	609c.9f2a.d480	
17/1/34	Down	None	None	None	None	no	N/A	0	609c.9f2a.d481	
17/1/35	Down	None	None	None	None	no	N/A	0	609c.9f2a.d482	
17/1/36	Down	None	None	None	None	no	N/A	0	609c.9f2a.d483	
17/1/37	Down	None	None	None	None	no	N/A	0	609c.9f2a.d484	
17/1/38	Down	None	None	None	None	no	N/A	0	609c.9f2a.d485	
17/1/39	Down	None	None	None	None	no	N/A	0	609c.9f2a.d486	
17/1/40	Down	None	None	None	None	no	N/A	0	609c.9f2a.d487	
17/1/41	Down	None	None	None	None	no	N/A	0	609c.9f2a.d488	
17/1/42	Down	None	None	None	None	no	N/A	0	609c.9f2a.d489	
17/1/43	Down	None	None	None	None	no	N/A	0	609c.9f2a.d48a	
17/1/44	Down	None	None	None	None	no	N/A	0	609c.9f2a.d48b	
17/1/45	Down	None	None	None	None	no	N/A	0	609c.9f2a.d48c	
17/1/46	Down	None	None	None	None	no	N/A	0	609c.9f2a.d48d	
17/1/47	Down	None	None	None	None	no	N/A	0	609c.9f2a.d48e	
17/1/48	Down	None	None	None	None	no	N/A	0	609c.9f2a.d48f	
17/2/1	Up	n/a	Full	10G	1	no	N/A	0	609c.9f2a.d491	
17/2/2	Up	n/a	Full	10G	1	no	N/A	0	609c.9f2a.d492	
17/2/3	Down	None	None	None	None	no	N/A	0	609c.9f2a.d493	
17/2/4	Down	None	None	None	None	no	N/A	0	609c.9f2a.d494	
17/3/1	Up	n/a	Full	40G	2	no	N/A	0	609c.9f2a.d495	
17/4/1	Up	n/a	Full	40G	2	no	N/A	0	609c.9f2a.d499	
lg1	Up	Forward	Full	20G	1	No	1	0	609c.9f2a.d491	

## Campus Fabric Manual Configuration

### Campus Fabric Detailed Manual Configuration Example

```
lg2          Up          Forward Full 80G  2    No  1    0    609c.9f2a.d495
mgmt1        Up          None    Full 1G   None No  None 0    609c.9f2a.d460
[PE]rconsole-17@ICX7450-48P Router#
```



# Campus Fabric Considerations for Layer 2, Layer 3, Multicast, Security, and QoS

- Campus Fabric Layer 2 Considerations..... 97
- Campus Fabric Layer 3 Unicast Considerations..... 99
- Campus Fabric and IP Multicast Considerations..... 100
- Campus Fabric Security Considerations..... 101
- Campus Fabric QoS Considerations..... 103

## Campus Fabric Layer 2 Considerations

In the CB (core) stack, Layer 2 forwarding is performed on the local unit. However, forwarding decisions for PE unit ports are made in the CB, not locally on the PE.

MAC learning is disabled in Campus Fabric PE units.

The CB stack maps each E-tag E-CID and its associated physical port to a virtual port. The CB supports Layer 2 forwarding between virtual ports and between virtual and physical ports. The CB is responsible for programming MAC addresses associated with the PE units for forwarding traffic to the PE units in the Campus Fabric domain.

VLAN filtering is performed in the CB. This means that on CB physical and virtual ports:

- Tagged packets (with a matching VLAN) are allowed on an untagged port.
- Untagged or priority tagged packets on a tagged port are not allowed and are dropped.
- All tagged, untagged, and priority tagged packets are allowed on dual-mode ports.

By default, each PE port is guaranteed membership in a maximum of four VLANs, including the default VLAN. You can increase the number of allowable memberships per PE port to any value from 5 through 1024 using the **max-vlan-per-pe-port** command. The potential pool for configuring PE VLAN contains 4096 entries and does not include the four default VLANs provisioned for the PE. Pool counters begin to increment only with the fifth VLAN. Use the **show spx pe-port-vlan-resource** command to check the number of available entries. The current non-default **max-vlan-per-pe-port** setting is displayed in **show running-config** command output.

The following table summarizes Layer 2 feature support available in a Campus Fabric domain.

**TABLE 10** Layer 2 Feature Support in a RUCKUS Campus Fabric Domain

Feature	Support
MAC FDB <ul style="list-style-type: none"> <li>• Learning</li> <li>• Aging</li> <li>• Move</li> <li>• Delete</li> <li>• Bulk flush</li> <li>• Disable learning per port</li> <li>• Configurable MAC age timer</li> </ul>	Yes for CB ports  Not supported for PE ports  Minimum age timer has increased to 60 seconds.
Port-based VLANs <ul style="list-style-type: none"> <li>• Untagged</li> <li>• Tagged</li> <li>• Dual Mode</li> </ul>	Yes for CB ports  Yes for PE ports

**TABLE 10** Layer 2 Feature Support in a RUCKUS Campus Fabric Domain (continued)

Feature	Support
Dynamic and Application VLANs (Layer 2 MAC table)	Yes for CB ports Not supported for PEs: Application VLANs
Static MMAC	Yes for CB ports Not supported on PE ports
MAC port security	Yes for CB ports Not supported on PE ports
Link aggregation <ul style="list-style-type: none"> <li>• Static LAG</li> <li>• LACP</li> <li>• Keep alive LAG</li> <li>• Add/Delete/Enable/Disable port</li> <li>• Short/Long timeout</li> <li>• Trunk threshold</li> <li>• LAG hardware failover</li> </ul>	Yes for CB ports Not supported on PE ports
xSTP <ul style="list-style-type: none"> <li>• Single/Global 802.1D</li> <li>• Single/Global 802.1W</li> <li>• Per VLAN 802.1D</li> <li>• Per VLAN 802.1W</li> <li>• 802.1S</li> <li>• Cisco PVST</li> <li>• BPDU Guard</li> <li>• Root Guard</li> <li>• Designated Guard</li> <li>• Error disable recovery</li> <li>• STP protect</li> <li>• Fast port span</li> <li>• Fast uplink span</li> </ul>	Yes Not supported for PEs: MSTP
Super-aggregated VLANs (SAV)/Q-in-Q using Tag Profile	Yes for CB ports Not supported for PE ports
Topology Groups <ul style="list-style-type: none"> <li>• STP</li> <li>• RSTP</li> <li>• MRP</li> <li>• VSRP</li> </ul>	Yes for CB ports Not supported for PE ports
VLAN Groups/VLAN range	Yes for CB ports Not supported for PEs: VLAN Group
Metro Ring Protocol (MRP)	Yes for CB ports Not supported for PEs

**TABLE 10** Layer 2 Feature Support in a RUCKUS Campus Fabric Domain (continued)

Feature	Support
Private VLAN <ul style="list-style-type: none"> <li>Tagged/Untagged port</li> <li>Isolated VLAN</li> <li>Community VLAN</li> <li>Primary VLAN</li> <li>Inter-Switch Link (ISL)</li> </ul>	Yes for CB ports Not supported for PEs
UDLD <ul style="list-style-type: none"> <li>Untagged and tagged port</li> <li>Per VLAN</li> </ul>	Yes for CB ports Not supported for PEs
VSRP	Yes for CB ports Not supported for PEs
MCT	Yes for CB ports Not supported for PEs
GVRP	Yes for CB ports Not supported for PEs
Loop Detect	Yes for CB ports Supported on untagged and dual-mode PE ports. Strict mode loop-detection is not supported on strictly tagged PE ports. The maximum loop detect interval value has been increased from 100 to 300 (30 seconds).
Link OAM	Yes for CB ports Not supported for PEs
Ethernet OAM	Yes for CB ports Not supported for PEs

## Campus Fabric Layer 3 Unicast Considerations

**NOTE**

When the L3\_MAX profile is enabled for the next hop routing table, SPX cannot be enabled, and vice versa. Refer to the *RUCKUS FastIron Layer 3 Routing Configuration Guide* for more information on configuring next-hop routing profiles.

The following table lists Layer 3 unicast features available in a Campus Fabric domain for ICX 7150, ICX 7250, or ICX 7450 devices enabled as PE units. Layer 3 features do not change for devices enabled as CB units.

**TABLE 11** Layer 3 Unicast Features in a Campus Fabric Domain

Layer 3	PE Support	
	IPv4	IPv6
Features and capabilities		
Static Routes	Yes	Yes
Host Routes	Yes	Yes
Virtual Interfaces	Yes	Yes
Routed Interfaces	Yes	Yes
Route-only Support	Yes	Yes

**TABLE 11** Layer 3 Unicast Features in a Campus Fabric Domain (continued)

Layer 3	PE Support	
RIP v1/v2 announce	Yes <sup>1</sup>	N/A
RIPv1/v2	Yes <sup>1</sup>	N/A
RIPng	N/A	No
OSPFv2	Yes <sup>1</sup>	N/A
OSPFv3	N/A	Yes <sup>1</sup>
ECMP	Yes <sup>2</sup>	Yes <sup>2</sup>
VRRP	Yes	N/A
VRRPv3	No	Yes
VRRP-E	Yes	Yes
VRRP-E SPF	Yes	Yes
IPv6 over IPv4 Tunnels	N/A	No <sup>3</sup>
Multi-VRF	Yes	Yes
IPv4 over GRE-IPv4 Tunnels	Yes <sup>1</sup>	N/A
BGP	Yes <sup>1</sup>	N/A
BGP4+	Yes <sup>1</sup>	Yes <sup>1</sup>

## Campus Fabric and IP Multicast Considerations

In a Campus Fabric domain, forwarding decisions always occur in the CB, even for incoming traffic on a PE port.

In the upstream direction (from a PE to a CB), the packets are tagged with an E-tag to identify the ingress PE or SPX port. In the downstream direction (from a CB to a PE), the packets are tagged with an E-tag to identify the egress PE ports. E-channel identifiers (E-CIDs) contained in the E-tag header are used to identify a single PE port or a set of PE ports.

### Multicast E-CID and IEEE 802.1BR

The point-to-multipoint E-channels used for remote replication are identified by an E-CID with a value in the range of 0x1000 to 0x3FFF (values less than this are reserved for E-CIDs associated with point-to-point E-channels).

### General Campus Fabric Multicast Considerations

Unless otherwise stated, Layer 2 and Layer 3 multicast features supported on a standalone ICX 7650, ICX 7750, or ICX 7850 are supported by the CB in a Campus Fabric domain, and the Layer 2 and Layer 3 scaling capacity are the same.

**NOTE**

An IP address cannot be configured on a PE port. Consequently, IPv4 and IPv6 multicast routing configuration is not supported on an IP interface for any PE unit.

<sup>1</sup> On a VE when the VE (VLAN) contains ports on a PE unit.

<sup>2</sup> Not supported on VP LAGs.

<sup>3</sup> Configuration is not blocked, but the feature is not supported. All IPv6 tunnel packets will be dropped.

**NOTE**

For details on Campus Fabric configuration for multicast, refer to the *RUCKUS FastIron IP Multicast Configuration Guide*.

## Considerations for Multicast Forwarding on PE Units

- The PE unit performs local replication of multi-destination traffic. The PE unit can perform replication within a VLAN, but not across VLANs.
- In a Campus Fabric domain, the following actions are not supported in a VLAN or VE on which multicast snooping or multicast routing is enabled:
  - Connecting a PIM router to a PE port.
  - Connecting a multicast (IGMP or MLD) querier switch to a PE port.
- Multi-destination traffic forwarding and replication on PE units is performed using forwarding entries in the Layer 2 table.
- A lookup is performed using a multicast E-CID in the E-tag header.
- Forwarding cache entries are set up, updated, or torn down based on the E-channel register Control and Status Protocol (CSP) messages from the CB unit.

## Campus Fabric Security Considerations

The following table indicates which security features are available on PE units in a Campus Fabric domain. All security features are available in a CB stack configuration, unless otherwise noted. Refer to the *RUCKUS FastIron Features and Standards Support Matrix* for additional information.

**NOTE**

ICX7400-SERVICE-MOD IPsec modules are not supported in ICX 7450 devices used as PE units.

**TABLE 12** Security Features Supported in a Campus Fabric Domain

Feature Group	Feature Name	FastIron Support
Security features - Layer 2	MAC filters	Yes
Security features - Layer 3	IPv4 ingress ACLs	Yes
	IPv6 ingress ACLs	Yes
	IPv4 egress (outbound) ACLs	Yes
	IPv6 egress (outbound) ACLs	Yes
Security features - DDoS attack protection	TCP-SYN attack prevention	Yes
	ICMP attack protection	Yes

**TABLE 12** Security Features Supported in a Campus Fabric Domain (continued)

Feature Group	Feature Name	FastIron Support
Security features - Services	Dynamic ARP Inspection	Yes
	ND Inspection	Yes
	DHCPv4 snooping	Yes
	DHCPv6 snooping	Yes
	IPv4 Source Guard	Yes
	IPv6 RA Guard	Yes
	Policy Based Routing	Yes
	RADIUS	Yes
	Flex-Authentication - dynamic ACLs	Yes
	Flex-Authentication - dynamic MAC filters	Yes
	Openflow	No
	Outbound ACLs for CPU traffic	Yes
	DSCP remarking	Yes
	PCP remarking	Yes
	ACL accounting	Yes
	ACL logging	Yes
	ACL-based traffic policy	Yes
	PPPVLAN	Yes
ACL on ARP	Yes	
Traffic management and monitoring	ARP rate limiting	Yes
	Ingress port rate limiting	Yes
	Egress port rate shaping	Yes
	ACL-based mirroring	Yes
	Web-auth	Yes <sup>4</sup>
	sFlow	Yes

## Security Design Considerations

From FastIron release 08.0.70 onward, the use of Campus Fabric and OpenFlow features are mutually exclusive by design.

## Security Performance Considerations

Pay attention to the following security performance considerations in a Campus Fabric domain:

- When more than 5,000 ACL filters are configured, PE units require significant time to resync following a reload. In a Campus Fabric domain with maximum ACL filters (8,000), the time required for PE units to resync is approximately 13 to 17 minutes.
- An ACL request is considered complete only after the request has been completed on every related unit. Consequently, an ACL request may take longer when it is distributed across CB and PE units.

<sup>4</sup> User-based ACLs are not supported in Web-auth for either CB or PE units.

- The distribution model is based on recovery from failure using a rollback mechanism, with the rollback occurring on each successful unit. The rollback mechanism can incur additional delays.
- All CLI requests are blocked on the security framework until ACL requests are completed.

## Additional Security Considerations

In a Campus Fabric domain, the following security considerations apply:

- Foundry Discovery Protocol (FDP) packets are blocked at PE interfaces, even when FDP pass through is configured. However, the packets are still forwarded upstream for processing in the CB. Although FDP neighbors can be displayed within the Campus Fabric domain, for example, with the **show fdp neighbor** command, no FDP packets are forwarded to non-SPX devices (that is, to devices that are connected to PEs but that are not part of the Campus Fabric domain).

# Campus Fabric QoS Considerations

## QoS Classifications for Campus Fabric PE Ports

In a Campus Fabric system, forwarding decisions for PE ports are made in the CB. When a PE unit receives frames through its extended ports, the PE appends an E-tag to each of the frames and transmits them to an upstream port toward the CB. After the CB makes forwarding decisions, the frames are forwarded to destination modules in the Campus Fabric domain. If the destination module is a PE unit, the frames are sent with an E-tag. The E-tag carries an E-PCP field consisting of three bits, which allows the E-PCP to carry eight priority classifications.

QoS classifications are supported for PE ports and are encoded in the E-PCP. A priority classified at an edge device is honored in both upstream and downstream directions. When congestion occurs in SPX ports, frames are dropped based on their priorities.

## QoS Features under Campus Fabric

The same QoS features available for devices in a normal configuration are supported on devices enabled as CB units in a Campus Fabric domain. Most QoS features available in a standard configuration are also available on devices enabled as PE units. Port-based features apply to CB local ports and PE ports.

**TABLE 13** QoS Feature Support on PE Units

Feature	PE Units
802 1p Quality of Service	Yes
DiffServ support	Yes
Port priority	Yes
Port trust DSCP	Yes
MAC address priority	No
QoS mappings	Yes
Global QoS egress queue scheduler	Yes
Port-based egress queue scheduler	Yes
Port-based egress buffer profile	Yes
Port-based ingress buffer profile	No
Priority-based flow control	No
Port-based symmetrical flow control	No

**TABLE 13** QoS Feature Support on PE Units (continued)

Feature	PE Units
Egress queuing statistics	Yes
sFlow	Yes

**NOTE**

Because forwarding decisions are made in the CB and MAC addresses are not learned in PE units, MAC address priority cannot be applied to PE SPX ports.

## QoS for SPX Ports

To ensure system stability, most QoS user configurations are not allowed for SPX ports. The following limitations apply to QoS in a Campus Fabric domain:

- Port-based classification cannot be applied to SPX ports. SPX ports are set to honor the E-PCP.
- Port flow control is disabled to preserve cascade or uplink port bandwidth.
- Priority-based flow control is disabled.
- The egress queue scheduler runs in mixed SP WRR mode under **qos mechanism**. A user-configured scheduler cannot be applied to SPX ports.
- A user-defined ingress or egress buffer profile cannot be applied to SPX ports.

## Performance Impact

SPX ports on PE and CB units carry an E-tag as part of the frame. The E-tag adds eight bytes of overhead, which should be taken into account when calculating port or system throughput.

## Control Packets under SPX

Upper layer protocols, such as routing and multicast protocols, run in the CB. When a PE port receives control packets for these protocols, the PE unit assigns the appropriate priority to each packet before forwarding it to the CB. The same priority applies for each type of control packet when it is sent to PE ports downstream.

**TABLE 14** QoS Control Packets

QoS Priority	Protocols
P7	Stacking Control, CSP Control for SPX, SPX LLDP (Ether type 0x88CB)
P6	Layer 2 Control: LACP, UDLD (802.3ah), STP, RSTP, PVST, MRP, LLDP Others: VRRP (v4 and v6), VRRP-E (v4 and v6), GRE keep-alive
P5	BGP, DHCP, OSPF (v2 and v3), RIP v2, PIM, ICMP
P4	IGMP, MLD, ARP, RIP v1, IPv6 ND
P3	–
P2	–
P1	sFLOW
P0	–



# Campus Fabric Management

---

• Logging in through the Console Port.....	105
• Using the Remote CB Console.....	106
• Changing the Speed on an SPX Link.....	107
• Handling Nonoperational PE Units.....	111
• Assigning an ID to a PE Unit.....	111
• Replacing a PE Unit.....	112
• Replacing PE Units with the Zero-touch or SPX Interactive Utility.....	113
• Moving a PE Unit and Retaining Its ID (Manual Methods).....	117
• Removing a PE Ring and Its Configuration.....	119
• Configuring SPX Ports and LAGs on a Live System.....	131
• Campus Fabric (SPX) Image Upgrade.....	133
• Unconfiguring the CB Stack or PE Units.....	136
• CB Stack Merges and Breaks.....	139
• Displaying Campus Fabric (SPX) Information.....	139
• Campus Fabric mirroring overview.....	149
• MIB support for Campus Fabric 802.1br SPX configurations.....	151

## Logging in through the Console Port

When a device becomes a stack member, it establishes a remote connection to a virtual console port on the active controller. Input and output are relayed between the physical console port on the stack member and the virtual console port on the active controller. Because each stack member connects to an independent virtual console port on the active controller, the console ports on multiple stack units may be used simultaneously.

When a stack unit establishes communication with the active controller, it also establishes a remote console session to the active controller. In a normally functioning stack, a console cable may be connected to any of the stack units and provide access to the same commands on the active controller.

To establish a remote console session on a stack unit, enter the **rconsole** command followed by the stack unit ID as shown in the following example.

```
device# rconsole 1
```

You can terminate a session between stack members in any of these ways:

- Enter the **logout** command at any level.
- Enter the **exit** command from the User EXEC level.

### NOTE

For **rconsole** connections from stack units to the active controller, the escape sequence and other methods of terminating the session are not available.

### NOTE

Error messages that are generated during a reload of the active controller do not appear on **rconsole** connections from stack units to the active controller. To see these error messages, you must connect a console cable to the active controller itself.

The following example shows how to establish a remote console session to a stack member and obtain status information. Notice that the **show stack** command on the stack member displays different information from what is shown when the **show stack** command is entered on the active controller.

A remote console session is established with stack unit 2 in the following example.

```
device# rconsole 2
Connecting to unit 2... (Press Ctrl-O X to exit)
rconsole-2@device# show stack
ID   Type      Role      Mac Address      Prio  State   Comment
2   D   ICX7650-48F  standby  94fd.2e05.1a10   0     local   Ready
rconsole-2@device# exit
rconsole-2@device> exit
Disconnected. Returning to local session...
```

**NOTE**

You can also use the **rconsole** command followed by the PE ID from a CB unit to reach a PE unit.

## Using the Remote CB Console

As in traditional stacking, remote console capability in a Campus Fabric domain allows the console from one unit to access the console of a second unit, for example, for monitoring and debugging.

The **rconsole** command allows for different types of remote access in a Campus Fabric domain:

- Monitor a PE unit from a standalone router or switch operating in regular mode.
- Access a PE unit console from a CB (core stack) member console.
- Access a CB member console from a PE unit console when the unit is in PE mode.
- Access the active controller of the CB from the console of another CB member.
- Access the active controller of the CB from a PE unit.

**NOTE**

When a PE unit is in Provisional-PE mode, the **rconsole** command is not available.

The following example is useful if the remote console connection with the CB has been broken.

In the following example, a CB member creates a remote connection with a PE unit.

```
ICX7650-48F Router# rconsole ?
DECIMAL  Unit number
ICX7650-48F Router# rconsole 17
Connecting to unit 17... (Press Ctrl Shift - x or type exit to exit)
[PE]rconsole-17@ICX7450-48P Router#
[PE]rconsole-17@ICX7450-48P Router# exit

Disconnected. Returning to local session...
ICX7650-48F Router#
```

## PE Console Port Behavior

Once a PE unit has joined the Campus Fabric network, its console is automatically redirected to the console of the CB active controller. This behavior is consistent with the behavior of stack members when they join a traditional stack. Automatic redirection of a PE to the CB console allows a network administrator to authenticate and manage the Campus Fabric network from a local PE, if desired, rather than from the CB, which may be in a remote location.

A PE candidate and a provisional PE have a local console connection indicated by the device prompt as shown in the following example.

```
[PE]local-17@ICX7450-48P Router#
```

When the PE's local console has been automatically redirected to the CB, the prompt on the PE unit changes to reflect the connection and shows the prefix "rconsole-#@" in front of the device type.

System output indicates when the PE has joined the network and when the console has been redirected to the CB as shown in the following example.

```
Connecting to control-bridge 1 console... (Press Ctrl Shift - x to exit)
ICX7650-48F Router>
```

Thereafter, the PE prompt indicates the remote CB connection as shown in the following example.

```
[PE]rconsole-17@ICX7450-48P Router# show running-config
Current configuration:
!
ver 08.0.80B7T213
!
spx pe-enable
spx unit 17
pe-name finance
module 1 icx7450-48p-poe-management-module
module 2 icx7400-xgc-4port-40g-module
module 3 icx7400-qsfp-1port-40g-module
module 4 icx7400-qsfp-1port-40g-module
spx-lag 17/2/1 to 17/2/2
spx-lag 17/3/1 17/4/1
!
jumbo
!
End
```

If a PE loses connection to the CB, its console returns to the local PE console.

### Accessing the PE Console

If you want to access the PE's local console, you can enter **Ctrl Shift - x** on the PE local console.

You can also use the **rconsole** command followed by the PE unit ID to connect to a PE unit from any CB console. Here, the CB console could be the CB local console, or it could be another PE console that is redirected to the CB as shown in the following example.

```
[PE]rconsole-17@ICX7450-48P Router# rconsole 24
```

## Changing the Speed on an SPX Link

From FastIron release 08.0.80, 1-Gbps SPX connections are supported between CB units and PE units. Ports on CB units intended to provide SPX links to attached PE units are likely to be configured with different speeds. The following procedure explains how to change the speed and form an active SPX connection to a directly attached PE unit. The same approach can be used to change to another speed, for example, 10-Gbps SPX links.

#### NOTE

To change the speed between a 10-Gbps cascade PE and new potential PE units connected to it, refer to [Converting 1-Gbps SPX Links on Downstream PEs to 10-Gbps Links](#) on page 108.

1. From the active controller of the CB, unconfigure the SPX port or LAG to convert it to a data connection.

#### NOTE

The **no multi-spx-lag** command cannot be used to remove the sole link from the PE to the CB. In this case, refer to [Converting Attached PE Candidate Speed by Physically Disconnecting the Units](#) on page 110.

```
device# configure terminal
device(config)# spx unit 17 Converting Attached PE Candidate Speed by Physically Disconnecting the Units on page 110
device(config-spx-unit-17)# no multi-spx-lag 17/2/1 17/2/3 and 2/1/31 2/1/32
device(config-spx-unit-17)# exit
```

The example removes SPX configuration from ports 17/2/1, 17/2/3, 2/1/31, and 2/1/32 and disables the ports.

2. Enable the resulting data port or ports, and use the **speed-duplex 1000-full** command to change the speed configuration to 1 Gbps.

```
device(config)# interface ethernet 17/2/1
device(config-if-pe-e10000-17/2/1)# enable
device(config-if-pe-e10000-17/2/1)# speed-duplex 1000-full
device(config-if-pe-e10000-17/2/1)# exit
device(config)# interface ethernet 17/2/3
device(config-if-pe-e10000-17/2/3)# enable
device(config-if-pe-e10000-17/2/3)# speed-duplex 1000-full
device(config-if-pe-e10000-17/2/3)# exit
device(config)# interface ethernet 2/1/31
device(config-if-pe-e10000-2/1/31)# enable
device(config-if-pe-e10000-2/1/31)# speed-duplex 1000-full
device(config-if-pe-e10000-2/1/31)# exit
device(config)# interface ethernet 2/1/32
device(config-if-pe-e10000-2/1/32)# enable
device(config-if-pe-e10000-2/1/32)# speed-duplex 1000-full
device(config-if-pe-e10000-2/1/32)# exit
```

The example enables the ports and changes the speed of the data ports formed when SPX configuration was removed.

3. Reconfigure the port or ports as SPX ports.

```
device(config)# spx unit 17
device(config-spx-unit-17)# spx-lag 17/2/1 17/2/3
device(config-spx-unit-17)# spx cb-configure
device(config-spx-cb)# spx-lag 2/1/31 2/1/32
device(config-spx-cb)# exit
device(config)#
```

## Converting 1-Gbps SPX Links on Downstream PEs to 10-Gbps Links

- Most ICX 7150 devices require a license for ports that will be used for 10-Gbps connections. The exception is the ICX 7150-48ZP model, which is shipped with two 10-Gbps ports but requires a license for any additional 10-Gbps connections. Refer to the *RUCKUS FastIron Software Licensing Guide* for information on installing ICX 7150 licenses.

#### NOTE

ICX 7150-C08P devices have no 10-Gbps-capable ports.

- ICX 7250 devices require a license for all ports that will be used for 10-Gbps connections. Refer to the *RUCKUS FastIron Software Licensing Guide* for information on licenses and downloading them.
- Stacking must be disabled on ICX 7150 and ICX 7250 units before they can be connected as PE units.

SPX links and LAGs do not allow speed negotiation. However, an attached ICX 7150 or ICX 7250 discoverable as a PE unit is allowed to have a 1-Gbps (1000-full duplex) configuration. For the attached unit to join and operate successfully as a PE unit over a 10-Gbps SPX link or LAG, the 1-Gbps link between it and an upstream device must be converted to 10 Gbps (see the example in the following figure) while the unit is still in Provisional-PE mode, before it is controlled by the CB.

**FIGURE 37** ICX 7250 PE Candidates for Conversion to 10 Gbps

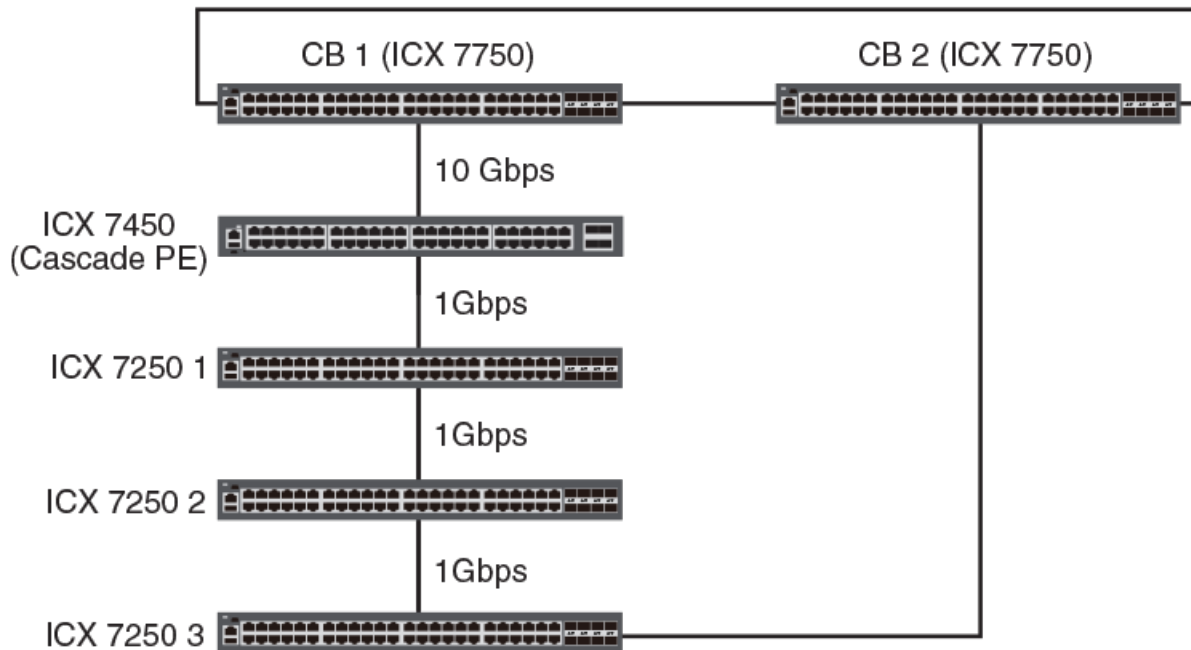

Perform these steps to convert a 1-Gbps SPX ring connection to a 10-Gbps SPX link or LAG between an ICX 7150 or ICX 7250 device and an active PE unit.

**NOTE**

The system does not allow the speed change unless the appropriate license is already installed. You can install the license to the PE units from the CB before disconnecting the PE units.

**NOTE**

The **no multi-spx port** and **no multi-spx lag** commands can be used only to break PE rings. The commands cannot be used to break a PE chain. If you are working with a PE chain, use the manual procedure described in [Converting Attached PE Candidate Speed by Physically Disconnecting the Units](#) on page 110.

1. Disable the SPX ports on both side of the link or LAG using the **no multi-spx port** or **no multi-spx lag** command.

```
device# configure terminal
device(config)# spx unit 18
device(config-spx-unit-18)# no multi-spx-lag 18/2/1 18/2/3 and 19/2/1 19/2/3
```

2. On the affected PE candidates, change the 1-Gbps optic to the desired 10-Gbps optic.

3. From the console, enter the **speed-duplex 10g-full** command for all affected ports, and specify appropriate media to change the speed of the upstream port or planned multiple-port LAG connection from 1 Gbps to 10 Gbps.

```
device(config)# interface ethernet 18/2/1
device(config-if-pe-e10000-18/2/1)# enable
device(config-if-pe-e10000-18/2/1)# speed-duplex 10g-full
device(config-if-pe-e10000-18/2/1)# exit
device(config)# interface ethernet 18/2/3
device(config-if-pe-e10000-18/2/3)# enable
device(config-if-pe-e10000-18/2/3)# speed-duplex 10g-full
device(config-if-pe-e10000-18/2/3)# exit
device(config)# interface ethernet 19/2/1
device(config-if-pe-e10000-19/2/1)# enable
device(config-if-pe-e10000-19/2/1)# speed-duplex 10g-full
device(config-if-pe-e10000-19/2/1)# exit
device(config)# interface ethernet 19/2/3
device(config-if-pe-e10000-19/2/3)# enable
device(config-if-pe-e10000-19/2/3)# speed-duplex 10g-full
device(config-if-pe-e10000-19/2/3)# exit
```

4. Reconfigure all affected ports as SPX ports or SPX LAGs.

```
device(config)# spx unit 18
device(config-spx-unit-18)# spx-lag 18/2/1 18/2/3
device(config-spx-unit-18)# exit
device(config)#spx unit 19
device(config-spx-unit-19)# spx-lag 19/2/1 19/2/3
device(config-spx-unit-19)# exit
```

5. Reconfigure the connecting SPX port or LAG of any additional downstream ICX 7150 or ICX 7250 devices in the same way, changing the 1-Gbps SPX port or LAG to a 10-Gbps SPX port or LAG connection.

## Converting Attached PE Candidate Speed by Physically Disconnecting the Units

As an alternative, you can perform the following steps on an existing PE ring or PE chain to convert a 1-Gbps SPX connection to a 10-Gbps SPX link or LAG between an ICX 7150 or ICX 7250 device and an active PE unit. The procedure requires physically disconnecting the units.

### NOTE

This is the required procedure for converting PE units in a chain.

### NOTE

The system does not allow the speed change unless the appropriate license is already installed. You can install the license to the PE units from the CB before disconnecting the PE units.

1. From the CB, reload the downstream ICX 7150 or ICX 7250 PE device that is connected to an upstream PE over a 1-Gbps SPX port or LAG.
2. While the downstream PE unit reloads and loses its connection to the upstream PE, remove the connecting 1-Gbps SPX port or LAG from the upstream PE.
3. When the downstream ICX 7150 or ICX 7250 unit boots up, it is not controlled by the CB but can be configured through its local console. From the local console of the new ICX 7150 or ICX 7250 unit, enter the **speed-duplex 10g-full** command, and specify appropriate media to change the speed of the upstream SPX port or LAG connection from 1 Gbps to 10 Gbps.
4. Reconfigure the connecting SPX port or LAG of any additional downstream ICX 7150 or ICX 7250 devices from their local consoles in the same way, changing the 1-Gbps SPX port or LAG to a 10-Gbps SPX port or LAG connection.

## Handling Nonoperational PE Units

The CB can access nonoperational units through an SPX link to correct common issues.

A PE unit may become nonoperational for the following reasons:

- The PE is running an image version that does not match the version on the CB.
- The modules installed on the PE unit do not match the reserved configuration for the PE unit that is stored on the CB. For example, the reserved configuration on the CB contains a configuration for SPX unit 18 with a 48-port module in slot 1, but the actual PE unit has a 24-port module installed in slot 1. In this case, you can remove the reserved configuration of the nonoperational SPX unit 18 with the **no spx unit 18** command so the CB can learn unit 18 modules correctly. Refer to [Adding a Reserved PE Configuration on the CB](#) on page 72 for more information.

All data ports, except for SPX ports or SPX LAGs, in a nonoperational PE are shut down. The CB can still control the nonoperational PE in the following limited ways:

- The CB can download the correct images to the PE unit. Refer to [Adding a Reserved PE Configuration on the CB](#) on page 72 for more information.
- The CB can unconfigure the PE unit to convert it to a regular router. Refer to [Unconfiguring the CB Stack or PE Units](#) on page 136.
- The CB can reload the PE unit.

## Assigning an ID to a PE Unit

A PE unit does not carry its ID. Its ID is always assigned when it joins a CB.

### NOTE

The zero-touch utility automatically assigns IDs to new PE units. Refer to [Zero-touch Configuration](#) on page 52 for more information.

### NOTE

The SPX interactive-setup utility suggests PE IDs for new units and asks for user confirmation. The user can change the IDs if necessary. Refer to [SPX Interactive-setup](#) on page 57 for more information.

A PE ID can be assigned in different ways:

- You can use SPX interactive-setup option 1 to change the IDs of existing PEs.
- You can use SPX interactive-setup option 2 or 3 to assign an ID to a PE candidate.
- You can create a PE ID on the CB as part of an SPX unit configuration. The PE ID is assigned to a PE that joins with a matching configuration on the specified port.

The following example creates two PE IDs, 20 and 21, for CB SPX port 1/1/10. The first PE unit that joins on SPX port 1/1/10 will be assigned a unit ID of 20. The second PE unit to join on the same port will be assigned a unit ID of 22.

```
ICX7650-48F Router# configure terminal
ICX7650-48F Router(config)# spx cb-config
ICX7650-48F Router(config-spx-cb)# spx-port 1/1/10
ICX7650-48F Router(config-spx-cb)# pe-id 1/1/10 20 22
```

The following example creates the same PE IDs for the same port, based on the name associated with the CB's SPX port.

```
ICX7650-48F Router# configure terminal
ICX7650-48F Router(config)# spx cb-config
ICX7650-48F Router(config-spx-cb)# spx-port 1/1/10 pe-group finance
ICX7650-48F Router(config-spx-cb)# pe-id finance 20 22
```

The following example creates the same PE IDs for the SPX connection, based on another port in the same SPX LAG.

```
ICX7650-48F Router# configure terminal
ICX7650-48F Router(config)# spx cb-config
ICX7650-48F Router(config-spx-cb)# spx-lag 1/1/10 1/1/11
ICX7650-48F Router(config-spx-cb)# pe-id 1/1/11 20 22
```

- You can configure a suggested ID on the PE unit before it joins the CB. The suggested ID may be overridden by the CB, however. For example, if the PE unit joins the CB and matches **pe-id** configuration, the PE unit will be assigned the PE ID from the **pe-id** configuration instead of the suggested ID. The CB also does not assign the suggested ID if the ID is already in use on an active PE unit or if the ID exists in a **pe-id** configuration.

The following example creates a suggested ID of 20 on an ICX 7450 in Provisional-PE mode.

```
ICX7450-48F Router# configure terminal
ICX7450-48F Router(config)# spx pe-enable
[Provisional-PE]ICX7450-48F Router(config)# spx suggested-id 20
```

- If no suggested ID is configured for it, the PE unit may be assigned its old ID if the previous ID has not been used in any **pe-id** configuration.
- The CB assigns the PE an unused ID; that is, one that is not active or present in another **pe-id** configuration.

## Assigning a PE ID that Has Been Taken

Follow these steps to assign a different PE unit a PE ID that is already taken.

### NOTE

Re-configuring a PE to use an existing PE ID may cause traffic interruption if the module and port configurations or the port connections do not match.

1. Physically disconnect the PE units to be changed.
2. Remove the **pe-id** configuration from the affected PE units, and reconfigure them using **pe-id** configurations that work with the new IDs.
3. Execute the **write memory** command to save the new **pe-id** configurations.

The following example reconfigures two PE IDs when PE unit 17 and PE unit 18 have been manually swapped, so that port 1/1/3 becomes associated with PE 17, and port 1/1/6 becomes associated with PE 18.

```
<-- Disconnect units before changing
the pe-id configuration.

ICX7650-48F Router# configure terminal
ICX7650-48F Router(config)# spx cb-config
ICX7650-48F Router(config-spx-cb)# no pe-id 1/1/3 18 17 1/1/16
ICX7650-48F Router(config-spx-cb)# pe-id 1/1/3 17 18 1/1/16 <-- Reconnect swapped units
after entering the new
pe-id configuration.

ICX7650-48F Router(config-spx-cb)# exit
ICX7650-48F Router(config)# exit
ICX7650-48F Router# write memory
```

## Replacing a PE Unit

CB stack members can be replaced by a new unit, and the new unit automatically becomes part of the stack when stacking links are connected. This feature works as in previous releases for traditional stack members. Refer to the *RUCKUS FastIron Stacking Configuration Guide* for more information on stack behavior.



When a PE unit is removed and a new PE unit is detected by the CB, the CB and the PE unit follow a standard initialization sequence. If the previous PE configuration is static (is still present on the CB) and the new PE unit contains a matching configuration, the PE joins and is assigned its old PE ID.

When you replace a PE unit with an existing PE of the same model, make sure that **spx allow-pe-movement** is not configured.

## Converting a Unit to Serve as a Replacement PE

### NOTE

The previous description applies when a PE is replaced by another existing PE.

If the replacement unit is running in switch or router mode, follow one of these procedures to convert it to a PE:

- [Manually Enabling and Configuring PE Units](#) on page 74
- [Replacing PE Units with the Zero-touch or SPX Interactive Utility](#) on page 113.

## Replacing PE Units with the Zero-touch or SPX Interactive Utility

You can use either the zero-touch or SPX interactive utility to replace existing PE units. If you use zero-touch, all replacement units must be new (clean) units.

### NOTE

The first time you enable zero-touch configuration, the system sends a zero-touch probe within 60 seconds. If a port specified in the **zero-touch-ports** configuration or a CB SPX port or LAG with no connection becomes active, a zero-touch probe is also triggered within a minute. Otherwise, a probe is sent every three minutes. It is recommended that you disable zero-touch provisioning once PE discovery is complete.

If the replacement unit has startup configuration, you must use the SPX interactive setup utility. The SPX interactive-setup utility can also be used for clean units.

Follow these steps to replace one or more PE units. The detailed example following the procedure uses SPX interactive-setup to replace two PE units.

1. Execute the **write memory** command if you have not already done so.

```
device# write memory
```

2. Power down the unit or units to be replaced, and remove connections.
3. Replace each PE unit with a new unit or a unit running switch or router mode.
4. If the replacement units are clean units and you opt to use the zero-touch utility, enter the **zero-touch-enable** command; otherwise, skip to the next step.

```
device# configure terminal
device(config)# spx cb-configure
device(config-spx-cb)# zero-touch-enable
```

The zero-touch utility discovers the replacement units and assigns them the PE IDs of the units they are replacing. Then it reloads the replacement units as PEs.

## Campus Fabric Management

Replacing PE Units with the Zero-touch or SPX Interactive Utility

### 5. **NOTE**

Follow this step only after disabling the **zero-touch-enable** command.

If the replacement units are in switch or router mode, run the `spx interactive-setup` utility, and select option 3. If you are using the utility to discover new units, select option 2.

```
device# spx interactive-setup
You can abort spx interactive-setup at any stage by <ctrl-c>
0: quit
1: change PE IDs
2: discover and convert new units (no startup-config flash) to PEs
3: discover and convert existing/new standalone units to PEs
2&3 can also find new links and convert chain(s) to ring.
Please type your selection: 3
Probing topology to find new units...
```

The SPX interactive-setup utility discovers the replacement units and assigns them the PE IDs of the units they are replacing. Then it reloads the replacement units as PEs.

The following set of examples replaces two PE units. In the example below, the active Campus Fabric configuration is first saved. The **show spx** command displays the Campus Fabric topology. The **show running-config** command displays details on the active configuration, including details on the modules installed in each CB and PE unit. The output shows that Campus Fabric is enabled (**spx cb-enable**) and lists the configured SPX ports and SPX LAGs. It indicates a ring of three PE units (20, 27, and 24) are connected through CB-SPX ports 1/1/1 and 1/1/3. Port 1/1/3 is part of a two-port SPX LAG.

```
device# write memory
device# show spx
T=12m21.0: alone: standalone, D: dynamic cfg, S: static
ID  Type          Role      Mac Address   Pri State Comment
1   S ICX7750-48XGF  standby  609c.9f1f.9900 128 remote Ready
2   S ICX7750-48XGF  active   cc4e.246d.9b00 128 local  Ready
20  D ICX7450-48GF   spx-pe   cc4e.246d.10b8 N/A remote Ready
24  D ICX7450-48G   spx-pe   cc4e.248e.2f90 N/A remote Ready
27  D ICX7450-48GF   spx-pe   cc4e.246c.f850 N/A remote Ready
```

```

active          standby
+----+         +----+
| 2 |2/4--2/1| 1 |2/4
+----+         +----+
          +----+ +----+ +----+ +----+
1/1/1--2/1| 20 |2/3--2/3| 27 |2/1--2/3| 24 |2/1==1/1/3
          +----+ +----+ +----+

```

```
device# show running-config
Current configuration:
!
ver 08.0.50b1T203
!
stack unit 1
  module 1 icx7750-48-xgf-port-management-module
  module 2 icx7750-qsfp-6port-qsfp-240g-module
  priority 128
  stack-port 1/2/1 1/2/4
stack unit 2
  module 1 icx7750-48-xgf-port-management-module
  module 2 icx7750-qsfp-6port-qsfp-240g-module
  module 3 icx7750-6q-6port-qsfp-240g-module
  priority 128
  stack-port 2/2/4
spx unit 20
  module 1 icx7450-48f-sf-port-management-module
  module 2 icx7400-xgf-4port-40g-module
  module 3 icx7400-xgf-4port-40g-module
  module 4 icx7400-xgf-4port-40g-module
  spx-port 20/2/1
  spx-port 20/2/3
spx unit 24
  module 1 icx7450-48-port-management-module
  module 2 icx7400-xgf-4port-40g-module
  module 3 icx7400-qsfp-lport-40g-module
  module 4 icx7400-qsfp-lport-40g-module
  spx-lag 24/2/1 to 24/2/2
  spx-port 24/2/3
spx unit 27
  module 1 icx7450-48f-sf-port-management-module
  module 2 icx7400-xgf-4port-40g-module
  module 3 icx7400-qsfp-lport-40g-module
  module 4 icx7400-qsfp-lport-40g-module
  spx-port 27/2/1
  spx-port 27/2/3
stack enable
stack rconsole-off
stack mac 609c.9f1f.9900
!
!
!
spx cb-enable
spx cb-configure
```

## Campus Fabric Management

Replacing PE Units with the Zero-touch or SPX Interactive Utility

```
spx-port 1/1/1
spx-lag 1/1/3 to 1/1/4
pe-id 1/1/1 20 27 24 1/1/3
!
```

In the following example, PE 24 and PE 27 have been powered down, disconnected, replaced by two new units, and reconnected. The **show spx** command displays the current Campus Fabric topology. All units are listed; however, the two units that were removed are in the "reserve" state, and the topology is no longer complete (the PE units and their SPX connections are lost).

```
device# show spx
T=16m0.6: alone: standalone, D: dynamic cfg, S: static
ID  Type      Role      Mac Address      Pri State  Comment
1   S ICX7750-48XGF standby 609c.9f1f.9900 128 remote Ready
2   S ICX7750-48XGF active  cc4e.246d.9b00 128 local Ready
20  S ICX7450-48GF spx-pe  cc4e.246d.10b8 N/A remote Ready
24  S ICX7450-48G  spx-pe  0000.0000.0000 N/A reserve <-----unit lost
27  S ICX7450-48GF spx-pe  0000.0000.0000 N/A reserve <-----unit lost
```

```
active      standby
+----+      +----+
| 2 |2/4--2/1| 1 |2/4
+----+      +----+
          +-----+
1/1/1--2/1| 20 |2/3-
          +-----+
```

In the following example, the **spx interactive-setup** command is entered to discover the replacement PE units. In this example, menu option 2 is selected because the two replacement PE units have no configuration. (As an alternative, you can enable and run the zero-touch utility as explained earlier.) The SPX interactive-setup utility probes the existing Campus Fabric topology for new units. It discovers the two new units in the same positions as the PE units that were removed. The user is given the default option to accept each old PE ID in turn and presses **Enter** to accept each one. The utility presents the accepted topology and asks for user confirmation. Once the user accepts the topology, the utility reloads the replacement units as PE units.

```
device# spx interactive-setup
You can abort spx interactive-setup at any stage by <ctrl-c>
0: quit
1: change PE IDs
2: discover and convert new units (no startup-config flash) to PEs
3: discover and convert existing/new standalone units to PEs
2&3 can also find new links and convert chain(s) to ring.
Please type your selection: 2
Probing topology to find new units...

Horizontal bars link to discovered units. Vertical bars link to CB or PEs.

Chain #0: link to PE(s), so display PE chain(s). =====
#1: icx7450-48f-sf-port-management-module CC4E.246C.F850
#2: icx7450-48-port-management-module CC4E.248E.2F90
  +----+
  1/1/1--2/1| 20 |2/3-
    +----+

20/2/3      1/1/3
  |          ||
  |          ||
  2/3       2/1
+----+     +----+
| 1 |2/1--2/3| 2 |
+----+     +----+

Discovered 1 chain/ring
chain #0: Do you want to select this chain?(enter 'y' or 'n'): y
#2: icx7450-48-port-management CC4E.2489.1A00, type an ID (No: 0, default: 24): <----- Type Enter.
#1: icx7450-48f-sf-port-management CC4E.246E.1080, type an ID (No: 0, default: 27): <----- Type Enter.

You selected 2 unit(s): #1: ID=27, #2: ID=24,

          #1          #2
        +----+     +----+
1/1/1--2/1| 20 |2/3--2/3| 27 |2/1--2/3| 24 |2/1==1/1/3
        +----+     +----+     +----+

Proceeding will produce the above topology. Do you accept it? (enter 'y' or 'n'): y
spx interactive-setup discovers 1 chain(s). valid #=1, selected #=1
```

## Moving a PE Unit and Retaining Its ID (Manual Methods)

### NOTE

Using the **spx allow-pe-movement** command allows PEs to retain their IDs when they are disconnected and moved to another physical port. Refer to [Configuring SPX to Move PE Units without Changing IDs](#) on page 62 for more information.

There are two ways to move a PE unit or a chain of PE units to a different CB port and retain the PE ID so the port configurations under the PE ID that has been moved do not require changes.

1. On the CB, change or add the **pe-id** configuration for the CB port.

## Campus Fabric Management

### Moving a PE Unit and Retaining Its ID (Manual Methods)

2. Remove the **pe-id** configuration of the affected PE units (both moved and retained units) so the ID assignment is based on the suggested ID or the previous ID assigned to the PE unit.

Consider the two configurations shown in the following figure.

**FIGURE 38** Moving PE Units from One CB Port to Another

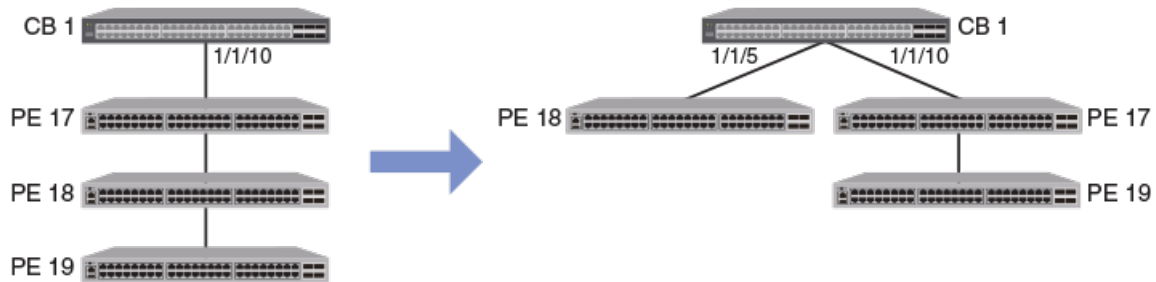

Suppose you want to move PE unit 18 to SPX port 1/1/5 on the CB. If you do not change the **pe-id** configuration from the CB, PE unit 18 will be assigned a new ID. PE unit 19, still connected on SPX port 1/1/10, becomes PE unit 18. As a result, the port configurations for PE unit 18 and 19 no longer apply to the renumbered units.

The following procedures describe the two options for retaining the PE ID for the moved PE unit.

## Method 1: Prepare a New Topology by Reconfiguring PE IDs on the CB

1. Disconnect PE unit 18 and 19 from the CB.

### NOTE

The **pe-id** configuration cannot be changed on a live unit.

2. Change the **pe-id** configuration on CB port 1/1/10 (from 17, 18, and 19 to 17 and 19).
3. Add PE ID 18 under the configuration for SPX port 1/1/5.
4. As shown in the CB configuration on the right in the previous figure, connect PE unit 18 to SPX port 1/1/5, and connect PE unit 19 to PE unit 17 on SPX port 1/1/10.
5. Enter the **write memory** command to save the configuration.

The following example changes the port configuration for SPX ports 1/1/10 and 1/1/5.

```
ICX7650-48F Router# configure terminal
ICX7650-48F Router(config)# spx cb-config
ICX7650-48F Router(config-spx-cb)# pe-id 1/1/10 17 19
ICX7650-48F Router(config-spx-cb)# pe-id 1/1/5 18
ICX7650-48F Router(config-spx-cb)# exit
ICX7650-48F Router(config)# exit
ICX7650-48F Router# write memory
```

## Method 2: Allow Suggested ID or Previous Unit ID Assignment

1. Disconnect PE units 18 and 19 from the CB.

2. On the CB, remove **pe-id** configuration for units 18 and 19 from CB port 1/1/10.

**NOTE**

You must retain **pe-id** configuration for PE unit 17 because it is still connected to the CB. If you try to remove it, the system blocks the command.

```
ICX7650-48F Router# configure terminal
ICX7650-48F Router(config)# spx cb-config
ICX7650-48F Router(config-spx-cb)# pe-id 1/1/10 17
!
!
!
```

3. On the local console for PE units 17, 18, and 19, remove the suggested ID if it is different from the previous assigned ID. If it is the same, you can remove it or keep it. The CB ID assignment will be based on the suggested ID or the previous ID.
4. Connect PE unit 18 to SPX port 1/1/5 and PE unit 19 to PE 17 on SPX port 1/1/10 as shown in the CB configuration on the right in the previous figure.

The CB assigns PE units 18 and 19 the desired ID, either based on the suggested ID that is configured or based on the unit's previous ID.

5. Enter the **write memory** command to save the configuration.

```
ICX7650-48F Router(config-spx-cb)# exit
ICX7650-48F Router(config)# exit
ICX7650-48F Router# write memory
```

## Removing a PE Ring and Its Configuration

**NOTE**

For information on physical ring formation, refer to [Best practice for PE ring configuration](#) on page 34.

**NOTE**

The PE ring can be broken into one or two chains while it is active using the **no multi-spx-port** or **no multi-spx-lag** command, or the ring can be physically disconnected first. The **no multi-spx-port** and **no multi-spx-lag** change SPX ports and SPX LAGs to data ports and put them in an administrative disabled state. You can configure the **no disable** or **enable** command in interface configuration mode to enable them.

To remove a ring and its configuration, either issue the **no multi-spx-port** or **no multi-spx-lag** command, or physically disconnect the ring by removing all SPX links either between the CB and a cascade PE unit, or between two PE units in the ring. You may also want to remove the two SPX links on each of the edge PEs that are unused after the connection is broken to allow the ports to be used as data ports.

## Campus Fabric Management

### Removing a PE Ring and Its Configuration

The following procedure steps you through the physical removal of a PE ring using a typical example.

1. Enter the **show spx** command to display Campus Fabric topology.

```
ICX 7750# show spx
T=18m44.4: alone: standalone, D: dynamic cfg, S: static
ID   Type           Role      Mac Address    Pri State  Comment
1   S ICX7750-48XGF  standby  609c.9f1f.9900 128 remote Ready
2   S ICX7750-48XGF  active   cc4e.246d.9b00 128 local  Ready
20  S ICX7450-48GF   spx-pe   cc4e.246d.10b8 N/A remote Ready
24  S ICX7450-48G    spx-pe   cc4e.248e.2f90 N/A remote Ready
27  S ICX7450-48GF   spx-pe   cc4e.246c.f850 N/A remote Ready

      active           standby
      +----+          +----+
      | 2 |2/4--2/1| 1 |2/4
      +----+          +----+
      +-----+      +-----+      +-----+
1/1/1--2/1| 20 |2/3--2/3| 27 |2/1--2/3| 24 |2/1==1/1/3
      +-----+      +-----+      +-----+
```

The Campus Fabric domain contains a two-unit CB stack and three connected PE units. The PE units are connected in a ring through CB SPX ports 1/1/1 and 1/1/3. Port 1/1/3 is part of a LAG connection.



- Enter the **show spx ring all** command to obtain details on PE rings in the domain. The output provides the Ring ID and the attached CB ports. Enter the **show spx ring** command followed by the correct ring ID to obtain more detail on the ring to be removed.

```
ICX 7750# show spx ring all
```

```
-----
Ring Id |FSM State |CB port  Lag  |Remote CB port  Lag  |Log Block Link
-----
1        ACTIVE   1/1/1   3072 1/1/3           3079  PE20x--xPE27
-----
```

The output confirms the presence of a single PE ring, Ring 1, and shows that it is active. It indicates that the logical block for this ring is between PE 20 and PE 27.

```
ICX 7750# show spx ring 1
```

```
=====
```

```
-----
Ring Id |FSM State |CB port  Lag  |Remote CB port  Lag  |Log Block Link
-----
1        ACTIVE   1/1/1   3072 1/1/3           3079  PE20x--xPE27
-----
```

CB chains Information:

```
-----
CB Port  Lag  | Epoch |Ring  Id   |FSM State|Remote CB port  Lag  | Chain
-----
1/1/1    3072  13     YES   1    |ACTIVE   1/1/3           3079  PE20x--xPE27--PE24
-----
```

PE chain information connecting to CB port 1/1/1 [Lag 3072]

```
-----
PE Id | Epoch | FSM state |Uplink port|Casc port|Log Block|Prev PE|Next PE
-----
PE20  13     ACTIVE    20/2/1     20/2/3   YES     --     x--x
-----
```

PE chain information connecting to remote CB port 1/1/3 [Lag 3079]

```
-----
PE Id | Epoch | FSM state |Uplink port|Casc port|Log Block|Prev PE|Next PE
-----
PE24  13     ACTIVE    24/2/1     24/2/3   NO      --     PE27
PE27  13     ACTIVE    27/2/1     27/2/3   YES     PE24   x--x
-----
```

The output lists all PE units in the ring ("Chain"), identifies the upstream ("Uplink") and downstream ("Cascade") port for each PE unit in the ring, specifies the previous and next PE in the chain, provides the logical block point, and displays the state of each PE.

3. Enter the **show running-config** command to check the details of the current configuration.

```

ICX 7750# show running-config
Current configuration:
!
ver 08.0.50b559T203
!
stack unit 1
  module 1 icx7750-48-xgf-port-management-module
  module 2 icx7750-qsfp-6port-qsfp-240g-module
  priority 128
  stack-port 1/2/1 1/2/4
stack unit 2
  module 1 icx7750-48-xgf-port-management-module
  module 2 icx7750-qsfp-6port-qsfp-240g-module
  module 3 icx7750-6q-6port-qsfp-240g-module
  priority 128
  stack-port 2/2/4
spx unit 20
  module 1 icx7450-48f-sf-port-management-module
  module 2 icx7400-xgf-4port-40g-module
  module 3 icx7400-xgf-4port-40g-module
  module 4 icx7400-xgf-4port-40g-module
  spx-port 20/2/1
  spx-port 20/2/3
spx unit 24
  module 1 icx7450-48-port-management-module
  module 2 icx7400-xgf-4port-40g-module
  module 3 icx7400-qsfp-1port-40g-module
  module 4 icx7400-qsfp-1port-40g-module
  spx-lag 24/2/1 to 24/2/2
  spx-port 24/2/3
spx unit 27
  module 1 icx7450-48f-sf-port-management-module
  module 2 icx7400-xgf-4port-40g-module
  module 3 icx7400-qsfp-1port-40g-module
  module 4 icx7400-qsfp-1port-40g-module
  spx-port 27/2/1
  spx-port 27/2/3
stack enable
stack rconsole-off
stack mac 609c.9f1f.9900
!
!
!
spx cb-enable
spx cb-configure
  spx-port 1/1/1 | <--- Current CB SPX links to PEs.
  spx-lag 1/1/3 to 1/1/4 |
  pe-id 1/1/1 20 27 24 1/1/3 <--- Current pe-id configuration
                                connects through CB SPX ports
                                1/1/1 and 1/1/3.

```

The output includes current CB SPX port and LAG connections to the PEs and pe-id configuration.

4. Break the PE ring in one of two possible ways, depending on desired outcome.

- Issue the **no multi-spx-lag** or **no multi-spx-port** command. The SPX port and SPX LAG configurations are removed, and these ports are administratively disabled.
- Physically break the PE ring by removing all SPX links between the CB and a PE or between two PE units in the ring. The configuration is unchanged. Both ends of the link are still SPX ports or SPX LAGs.

A SYSLOG message is generated to indicate the ring has been broken. You can also confirm the break with the **show spx** and **show spx ring id** commands.

The following example shows breaking a ring by physically removing links. SPX port 20/2/3 and SPX port 27/2/3 configurations remain. If you use the other option of entering the command **no multi-spx-port 20/2/3 and 27/2/3**, configuration for SPX port 20/2/3 and SPX port 27/2/3 is removed, and both ports are administratively disabled. (Whenever an SPX port or an SPX LAG is converted to a data port, it is administratively disabled. You can enable a port by configuring the **enable** or **no disable** in interface configuration mode.)

```
ICX 7750# show spx
T=22m11.7: alone: standalone, D: dynamic cfg, S: static
ID  Type      Role      Mac Address  Pri  State  Comment
1   S  ICX7750-48XGF  standby  609c.9f1f.9900 128  remote Ready
2   S  ICX7750-48XGF  active   cc4e.246d.9b00 128  local  Ready
20  S  ICX7450-48GF  spx-pe   cc4e.246d.10b8 N/A  remote Ready
24  S  ICX7450-48G  spx-pe   cc4e.248e.2f90 N/A  remote Ready
27  S  ICX7450-48GF  spx-pe   cc4e.246c.f850 N/A  remote Ready

      active          standby
      +----+          +----+
      | 2 |2/4--2/1| 1 |2/4
      +----+          +----+
      +-----+
1/1/1--2/1| 20 |2/3- <--20/2/3 port down
      +----+

      +-----+          +-----+
1/1/3==2/1| 24 |2/3--2/1| 27 |2/3- <--27/2/3 port down
      +----+          +-----+
```

In this case, the SPX port 20/2/3 is disconnected from SPX port 27/2/3 as shown in the **show spx** topology.

```
ICX 7750# show spx ring 1
```

```
-----
Ring Id |FSM State |CB port  Lag  |Remote CB port  Lag  |Log Block Link
-----
1       BREAK   1/1/1   3072 |1/1/3           3079 |Ring is broken - No Logical Block
-----
```

CB chains Information:

```
-----
CB Port  Lag  | Epoch |Ring  Id    |FSM State|Remote CB port  Lag  | Chain
-----
1/1/1    3072 14     YES   1     |BREAK   1/1/3           3079 | PE20
-----
```

PE chain information connecting to CB port 1/1/1 [Lag 3072]

```
-----
PE Id | Epoch | FSM state |Uplink port|Casc port|Log Block|Prev PE|Next PE
-----
PE20  14     BREAK     20/2/1     20/2/3   YES     --     --
-----
```

```
-----
CB Port  Lag  | Epoch |Ring  Id    |FSM State|Remote CB port  Lag  | Chain
-----
```

## Campus Fabric Management

### Removing a PE Ring and Its Configuration

```
1/1/3      3079 14      YES      1      BREAK      1/1/1      3072      PE24--PE27
```

PE chain information connecting to CB port 1/1/3 [Lag 3079]

PE Id	Epoch	FSM state	Uplink port	Casc port	Log Block	Prev PE	Next PE
PE24	14	BREAK	24/2/1	24/2/3	NO	--	PE27
PE27	14	BREAK	27/2/1	27/2/3	YES	PE24	--

The output of the **show spx ring id** command shows the ring and all its PE units in "Break" state.

```
ICX 7750# show running-config
Current configuration:
!
ver 08.0.50b559T203
!
stack unit 1
  module 1 icx7750-48-xgf-port-management-module
  module 2 icx7750-qsfp-6port-qsfp-240g-module
  priority 128
  stack-port 1/2/1 1/2/4
stack unit 2
  module 1 icx7750-48-xgf-port-management-module
  module 2 icx7750-qsfp-6port-qsfp-240g-module
  module 3 icx7750-6q-6port-qsfp-240g-module
  priority 128
  stack-port 2/2/4
spx unit 20
  module 1 icx7450-48f-sf-port-management-module
  module 2 icx7400-xgf-4port-40g-module
  module 3 icx7400-xgf-4port-40g-module
  module 4 icx7400-xgf-4port-40g-module
  spx-port 20/2/1
  spx-port 20/2/3
spx unit 24
  module 1 icx7450-48-port-management-module
  module 2 icx7400-xgf-4port-40g-module
  module 3 icx7400-qsfp-1port-40g-module
  module 4 icx7400-qsfp-1port-40g-module
  spx-lag 24/2/1 to 24/2/2
  spx-port 24/2/3
spx unit 27
  module 1 icx7450-48f-sf-port-management-module
  module 2 icx7400-xgf-4port-40g-module
  module 3 icx7400-qsfp-1port-40g-module
  module 4 icx7400-qsfp-1port-40g-module
  spx-port 27/2/1
  spx-port 27/2/3
stack enable
stack rconsole-off
stack mac 609c.9f1f.9900
!
!
!
spx cb-enable
spx cb-configure
  spx-port 1/1/1
  spx-lag 1/1/3 to 1/1/4
  pe-id 1/1/1 20 27 24 1/1/3 <--- No change in configuration
```

As shown in **show running-config** output, the current configuration has not changed.

- (Optional) To make the ports available as data ports, remove the unused SPX ports or LAGs from the edge PEs in the resulting chain or chains. There will be two unused SPX links if you disconnect the ring between two PE units as in this example.

#### NOTE

If you are planning to re-form the PE ring later, you do not need to remove the unused SPX links.

6. (Optional) To make the underlying ports available as data ports, remove the SPX ports or SPX LAGs that formed the ring with the **no spx-port** or the **no spx-lag** command.

**NOTE**

The **no spx-port** and **no spx-lag** commands change the ports to data ports and administratively disables them. You can configure the **no disable** or **enable** command in interface configuration mode to enable the ports.

```

ICX 7750# configure terminal
ICX 7750(config)# spx unit 20
ICX 7750(config-spx-unit-20)# no spx-port 20/2/3
spx-port 20/2/3 is removed

ICX 7750(config-spx-unit-20)# spx unit 27
ICX 7750(config-spx-unit-27)# no spx-port 27/2/3
spx-port 27/2/3 is removed

ICX 7750(config-spx-unit-27)# end
ICX 7750# show spx
T=25m14.6: alone: standalone, D: dynamic cfg, S: static
ID   Type           Role      Mac Address   Pri State  Comment
1   S ICX7750-48XGF  standby  609c.9f1f.9900 128 remote Ready
2   S ICX7750-48XGF  active   cc4e.246d.9b00 128 local  Ready
20  S ICX7450-48GF   spx-pe   cc4e.246d.10b8 N/A remote Ready
24  S ICX7450-48G    spx-pe   cc4e.248e.2f90 N/A remote Ready
27  S ICX7450-48GF   spx-pe   cc4e.246c.f850 N/A remote Ready

      active           standby
      +----+         +----+
      | 2 |2/4--2/1| 1 |2/4
      +----+         +----+
      +-----+
1/1/1--2/1| 20 |
      +-----+

      +-----+         +-----+
1/1/3==2/1| 24 |2/3--2/1| 27 |
      +-----+         +-----+

```

In the example, SPX ports 20/2/3 and 27/2/3 are removed. The output for the **show spx** command shows no connection between PE 20 and PE 27.

## Campus Fabric Management

### Removing a PE Ring and Its Configuration

- (Optional) To match the physical configuration, remove the ring from **pe-id** configuration and configure PE chains instead. If needed, first enter the **show spx ring all** and **show spx ring chain** commands for more information.

```
ICX 7750# show spx ring all
```

```
-----  
Ring Id |FSM State |CB port  Lag  |Remote CB port  Lag  |Log Block Link  
-----
```

The output confirms that no PE rings are present in the Campus Fabric topology.

```
ICX 7750# show spx ring chain
```

```
-----  
SPX CB [CASC PORT] CHAINS  
-----  
CB Port    Lag  | Epoch |Ring  Id    FSM State|Remote CB port  Lag  | Chain  
-----  
1/1/1      3072 17     NO    0     INIT    INVALID   0    PE20  
1/1/3      3079 17     NO    0     INIT    INVALID   0    PE24--PE27s  
-----
```

The output indicates a single cascade PE attached to CB port 1/1/1, and a chain of two PEs, PE 24 and PE 27, attached to CB port 1/1/3.

```
ICX 7750# configure terminal  
ICX 7750(config)# spx cb-configure  
ICX 7750(config-spx-cb)# pe-id 1/1/1 20  
  
SYSLOG: SPX SPX Ring Instance 1 is unconfigured (CB1/1/3 - CB1/1/1)  
ICX 7750(config-spx-cb)# end  
ICX 7750#
```

The example creates **pe-id** configuration 1/1/1 20, which replaces the original **pe-id** configuration (pe-id 1/1/1 20 27 24 1/1/3), thereby removing the configured ring. Correct **pe-id** configuration for PE 24 and PE 27 will be recreated when the configuration is saved.

- Enter the **write memory** command to save the configuration.

```
ICX 7750# write memory  
Send "write mem" to 3 PEs: 20,24,27  
  
Automatic copy to member units: 1  
Spx#  
SYSLOG: <14> Apr  2 15:29:17 Spx Security: startup-config was changed by operator from console  
Flash Memory Write (8192 bytes per dot)  
.....  
Copy Done.
```

The configuration is saved on the three PE units and on the CB active controller.

9. Confirm removal of the PE ring by entering the **show spx**, **show spx ring all**, and **show running-config** commands.

```
ICX 7750# show spx
T=28m42.0: alone: standalone, D: dynamic cfg, S: static
ID  Type          Role      Mac Address    Pri State  Comment
1   S ICX7750-48XGF  standby  609c.9f1f.9900 128 remote Ready
2   S ICX7750-48XGF  active   cc4e.246d.9b00 128 local  Ready
20  S ICX7450-48GF   spx-pe   cc4e.246d.10b8 N/A remote Ready
24  S ICX7450-48G    spx-pe   cc4e.248e.2f90 N/A remote Ready
27  S ICX7450-48GF   spx-pe   cc4e.246c.f850 N/A remote Ready
```

```

      active          standby
      +----+         +----+
      | 2 |2/4--2/1| 1 |2/4
      +----+         +----+
1/1/1--2/1| 20 |
      +----+
                                     +----+
1/1/3==2/1| 24 |2/3--2/1| 27 |
      +----+         +----+
```

The topology shows a single PE (PE 20) and a PE chain formed by PE 24 and PE 27.

```
ICX 7750# show spx ring all
```

```
-----
Ring Id |FSM State |CB port  Lag  |Remote CB port  Lag  |Log Block Link
-----
```

The output from the **show spx ring all** command shows no PE rings in the Campus Fabric domain.

```
SPX# show running-config
Current configuration:
!
ver 08.0.50b559T203
!
stack unit 1
  module 1 icx7750-48-xgf-port-management-module
  module 2 icx7750-qsfp-6port-qsfp-240g-module
  priority 128
  stack-port 1/2/1 1/2/4
stack unit 2
  module 1 icx7750-48-xgf-port-management-module
  module 2 icx7750-qsfp-6port-qsfp-240g-module
  module 3 icx7750-6q-6port-qsfp-240g-module
  priority 128
  stack-port 2/2/4
spx unit 20
  module 1 icx7450-48f-sf-port-management-module
  module 2 icx7400-xgf-4port-40g-module
  module 3 icx7400-xgf-4port-40g-module
  module 4 icx7400-xgf-4port-40g-module
  spx-port 20/2/1
spx unit 24
  module 1 icx7450-48-port-management-module
  module 2 icx7400-xgf-4port-40g-module
  module 3 icx7400-qsfp-lport-40g-module
  module 4 icx7400-qsfp-lport-40g-module
  spx-lag 24/2/1 to 24/2/2
  spx-port 24/2/3
spx unit 27
  module 1 icx7450-48f-sf-port-management-module
  module 2 icx7400-xgf-4port-40g-module
  module 3 icx7400-qsfp-lport-40g-module
  module 4 icx7400-qsfp-lport-40g-module
  spx-port 27/2/1
stack enable
stack rconsole-off
stack mac 609c.9f1f.9900
```

## Campus Fabric Management

### Removing a PE Ring and Its Configuration

```
!  
!  
!  
spx cb-enable  
spx cb-configure  
  spx-port 1/1/1  
  spx-lag 1/1/3 to 1/1/4  
  pe-id 1/1/1 20 <--- pe-id is split.  
  pe-id 1/1/3 24 27 <--- pe-id is split.  
!
```

The current configuration now matches the saved (as well as the physical) configuration and shows the PE ID configuration is broken out, with PE 20 connected at CB SPX port 1/1/1 and PEs 24 and 27 connected to the CB through an SPX LAG (ports 1/1/3 and 1/1/4).



## Example of Removing a PE Ring with the no multi-spx-lag Command

The following example removes the SPX LAG between PE 17 and PE 18 using the **no multi-spx-lag** command.

```
ICX7750-26Q Router# show spx
T=22h48m38.8: alone: standalone, D: dynamic cfg, S: static
ID   Type           Role      Mac Address      Pri State  Comment
1   S ICX7750-26QXG active    cc4e.2439.2a80  128 local  Ready
2   S ICX7750-26QXG standby  cc4e.2439.3700   0 remote Ready
3   S ICX7750-48XGC member    cc4e.2439.1680   0 remote Ready
17  S ICX7150-C12P  spx-pe   609c.9fbc.bf26  N/A remote Ready
18  S ICX7150-48ZP  spx-pe   609c.9fee.4320  N/A remote Ready
23  D ICX7450-48GF  spx-pe   cc4e.246c.f850  N/A remote Ready
24  D ICX7450-48P   spx-pe   609c.9fc2.3090  N/A remote Ready
25  D ICX7250-24    spx-pe   cc4e.24df.0ade  N/A remote Ready
```

```

standby      active
+----+      +----+      +----+
3/1| 2 |2/1==2/1| 1 |3/1==3/1| 3 |2/1
+----+      +----+      +----+
3/1/17==1/1| 18 |2/1==3/1| 17 |1/7==3/1/41
+----+      +----+
2/3/6--4/1| 23 |3/1--4/1| 24 |2/1--2/3| 25 |1/1--3/1/15
+----+      +----+      +----+

```

Standby u2 - protocols ready, can failover

```
ICX7750-26Q Router# write memory
Send "write mem" to 5 PEs: 17-18,23-25
Automatic copy to member units: 2 3
ICX7750-26Q Router#
Flash Memory Write (8192 bytes per dot)
.
Write startup-config done.
Copy Done.
```

Removing spx-lag between PE 17 and PE 18 using no multi-spx-lag command

```
ICX7750-26Q Router#
ICX7750-26Q Router# configure terminal
ICX7750-26Q Router(config)# spx cb-configure
ICX7750-26Q Router(config-spx-cb)# no multi-spx-lag 18/2/1 18/2/3 and 17/3/1 17/3/2
Bring down ports: 17/3/1 to 17/3/2 18/2/1 18/2/3
Wait for 20 sec before removing spx-lags. These ports will be disabled in configuration.
ICX7750-26Q Router(config-spx-cb)# end
ICX7750-26Q Router# show spx
T=22h50m28.3: alone: standalone, D: dynamic cfg, S: static
ID   Type           Role      Mac Address      Pri State  Comment
1   S ICX7750-26QXG active    cc4e.2439.2a80  128 local  Ready
2   S ICX7750-26QXG standby  cc4e.2439.3700   0 remote Ready
3   S ICX7750-48XGC member    cc4e.2439.1680   0 remote Ready
17  S ICX7150-C12P  spx-pe   609c.9fbc.bf26  N/A remote Ready
18  S ICX7150-48ZP  spx-pe   609c.9fee.4320  N/A remote Ready
23  S ICX7450-48GF  spx-pe   cc4e.246c.f850  N/A remote Ready
24  S ICX7450-48P   spx-pe   609c.9fc2.3090  N/A remote Ready
25  S ICX7250-24    spx-pe   cc4e.24df.0ade  N/A remote Ready
```

```

standby      active
+----+      +----+      +----+
3/1| 2 |2/1==2/1| 1 |3/1==3/1| 3 |2/1
+----+      +----+      +----+
3/1/41==1/7| 17 |3/1=
+----+
3/1/17==1/1| 18 |2/1=
+----+

```

## Campus Fabric Management

### Removing a PE Ring and Its Configuration

```
      +-----+      +-----+      +-----+
2/3/6--4/1| 23 |3/1--4/1| 24 |2/1--2/3| 25 |1/1--3/1/15
      +-----+      +-----+      +-----+
```

```
ICX7750-26Q Router# spx-lag 17/3/1 to 17/3/2 is removed
spx-lag 18/2/1 18/2/3 is removed
```

```
ICX7750-26Q Router#
ICX7750-26Q Router# show spx
T=22h50m41.6: alone: standalone, D: dynamic cfg, S: static
ID  Type      Role      Mac Address      Pri State  Comment
1   S ICX7750-26QXG active    cc4e.2439.2a80 128 local  Ready
2   S ICX7750-26QXG standby  cc4e.2439.3700  0 remote Ready
3   S ICX7750-48XGC member   cc4e.2439.1680  0 remote Ready
17  S ICX7150-C12P spx-pe   609c.9fbc.bf26 N/A remote Ready
18  S ICX7150-48ZP spx-pe   609c.9fee.4320 N/A remote Ready
23  S ICX7450-48GF spx-pe   cc4e.246c.f850 N/A remote Ready
24  S ICX7450-48P  spx-pe   609c.9fc2.3090 N/A remote Ready
25  S ICX7250-24   spx-pe   cc4e.24df.0ade N/A remote Ready
```

```
      standby      active
      +-----+      +-----+      +-----+
3/1| 2 |2/1==2/1| 1 |3/1==3/1| 3 |2/1
      +-----+      +-----+      +-----+
```

```
      +-----+
3/1/41==1/7| 17 |
      +-----+
```

```
      +-----+
3/1/17==1/1| 18 |
      +-----+
```

```
      +-----+      +-----+      +-----+
2/3/6--4/1| 23 |3/1--4/1| 24 |2/1--2/3| 25 |1/1--3/1/15
      +-----+      +-----+      +-----+
```

```
Standby u2 - protocols ready, can failover
ICX7750-26Q Router#
```

## Example of Removing a PE Ring with the no multi-spx-port Command

The following example removes the SPX ports between PE 24 and PE 25 using the **no multi-spx-port** command.

```
ICX7750-26Q Router# write memory
Send "write mem" to 5 PEs: 17-18,23-25
Automatic copy to member units: 2 3
ICX7750-26Q Router#
Flash Memory Write (8192 bytes per dot)
.
Write startup-config done.
Copy Done.
```

```
ICX7750-26Q Router(config)# spx cb-configure
ICX7750-26Q Router(config-spx-cb)# no multi-spx-port 24/2/1 and 25/2/3
Bring down 24/2/1 and 25/2/3
Wait for 20 sec before removing spx-ports. These ports will be disabled in configuration.
ICX7750-26Q Router(config-spx-cb)# end
ICX7750-26Q Router# show spx
T=22h55m20.8: alone: standalone, D: dynamic cfg, S: static
ID  Type          Role      Mac Address      Pri State  Comment
1   S ICX7750-26QXG active    cc4e.2439.2a80  128 local  Ready
2   S ICX7750-26QXG standby  cc4e.2439.3700   0 remote Ready
3   S ICX7750-48XGC member   cc4e.2439.1680   0 remote Ready
17  S ICX7150-C12P spx-pe   609c.9fbc.bf26  N/A remote Ready
18  S ICX7150-48ZP spx-pe   609c.9fee.4320  N/A remote Ready
23  S ICX7450-48GF spx-pe   cc4e.246c.f850  N/A remote Ready
24  S ICX7450-48P  spx-pe   609c.9fc2.3090  N/A remote Ready
25  S ICX7250-24   spx-pe   cc4e.24df.0ade  N/A remote Ready
```

```

standby      active
+----+      +----+      +----+
3/1| 2 |2/1==2/1| 1 |3/1==3/1| 3 |2/1
+----+      +----+      +----+
          +-----+
3/1/41==1/7| 17 |
          +-----+

          +-----+
3/1/17==1/1| 18 |
          +-----+

          +-----+      +-----+
2/3/6--4/1| 23 |3/1--4/1| 24 |2/1-
          +-----+      +-----+

          +-----+
3/1/15--1/1| 25 |2/3-
          +-----+

Standby u2 - protocols ready, can failover

ICX7750-26Q Router# spx-port 24/2/1 is removed
spx-port 25/2/3 is removed
```

## Configuring SPX Ports and LAGs on a Live System

You can create, modify, or remove an SPX LAG or link in a live configuration.

To prevent connection issues, the **multi-spx-lag** command changes both ends of a live CB-to-PE or PE-to-PE link at the same time to form an SPX LAG. The **multi-spx-port** command transforms a live SPX LAG into a single-port SPX link. Both the **multi-spx-port** and **multi-spx-lag** commands are available in SPX CB configuration mode and SPX unit configuration modes.

## Campus Fabric Management

### Configuring SPX Ports and LAGs on a Live System

#### NOTE

The system blocks the **multi-spx-port** or **multi-spx-lag** command if the command would make any PE unreachable.

For more information on SPX LAG formation and using port lists, refer to [Differences in Campus Fabric Configuration Practices](#) on page 42.

#### NOTE

You can use the **no mutli-spx-port** or **no multi-spx-lag** command to remove a live SPX link (two SPX ports) or a live SPX LAG in order to break a ring of PE units into one or two chains. Both ends of the live link become data ports that are administratively disabled in the configuration. These commands can be used as an alternative to physically disconnecting the links to break a ring of PEs.

The following example changes a live SPX LAG to a live link between CB unit 3 and PE unit 24.

```
ICX7750-26Q Router# configure terminal
ICX7750-26Q Router(config)# spx cb-config
ICX7750-26Q Router(config-spx-cb)# multi-spx-port 3/1/8 and 24/4/1
spx-lag 3/1/6 3/1/8 is replaced by spx-port 3/1/8.
spx-lag 24/3/1 24/4/1 is replaced by spx-port 24/4/1.
```

The following example creates a live SPX LAG between PE unit 17 and PE unit 24 as part of configuring PE unit 24 from the CB in SPX unit configuration mode.

```
ICX7750-26Q Router# configure terminal
ICX7750-26Q Router(config)# spx unit 24
ICX7750-26Q Router(config-spx-unit-24)# multi-spx-lag 24/2/1 to 24/2/2 and 17/2/1 17/2/2
spx-port 17/2/1 is replaced by spx-lag 17/2/1 to 17/2/2.
spx-port 24/2/1 is replaced by spx-lag 24/2/1 to 24/2/2.
```

The following example removes SPX ports between PE 24 and PE 25.

```

ICX7750-26Q Router(config)# spx cb-configure
ICX7750-26Q Router(config-spx-cb)# no multi-spx-port 24/2/1 and 25/2/3
Bring down 24/2/1 and 25/2/3
Wait for 20 sec before removing spx-ports. These ports will be disabled in configuration.
ICX7750-26Q Router(config-spx-cb)# end
ICX7750-26Q Router# show spx
T=22h55m20.8: alone: standalone, D: dynamic cfg, S: static
ID  Type          Role      Mac Address    Pri State  Comment
1   S ICX7750-26QXG active    cc4e.2439.2a80 128 local  Ready
2   S ICX7750-26QXG standby  cc4e.2439.3700 0 remote Ready
3   S ICX7750-48XGC member   cc4e.2439.1680 0 remote Ready
17  S ICX7150-C12P spx-pe   609c.9fbc.bf26 N/A remote Ready
18  S ICX7150-48ZP spx-pe   609c.9fee.4320 N/A remote Ready
23  S ICX7450-48GF spx-pe   cc4e.246c.f850 N/A remote Ready
24  S ICX7450-48P  spx-pe   609c.9fc2.3090 N/A remote Ready
25  S ICX7250-24   spx-pe   cc4e.24df.0ade N/A remote Ready

standby          active
+----+          +----+          +----+
3/1| 2 |2/1==2/1| 1 |3/1==3/1| 3 |2/1
+----+          +----+          +----+
                    +----+
3/1/41==1/7| 17 |
                    +----+

                    +----+
3/1/17==1/1| 18 |
                    +----+

                    +----+          +----+
2/3/6--4/1| 23 |3/1--4/1| 24 |2/1-
+----+          +----+

                    +----+
3/1/15--1/1| 25 |2/3-
+----+

Standby u2 - protocols ready, can failover
ICX7750-26Q Router# spx-port 24/2/1 is removed
spx-port 25/2/3 is removed

```

## Campus Fabric (SPX) Image Upgrade

Any unit that is part of a Campus Fabric domain is automatically updated with the correct image if an image mismatch within the same major version occurs.

### NOTE

A PE candidate can be discovered and added to the Campus Fabric Domain by the zero-touch or the SPX interactive-setup utility; however, because Campus Fabric requires a router image, the new device will initially be in a non-operational state due to an image mismatch. If **fttp-server** is configured and **image-auto-copy** is not disabled, the CB will download a router image to a non-operational PE unit. The PE reloads, joins the Campus Fabric domain, and becomes operational.

### NOTE

If the CB and PE are running different major release versions, for example, FastIron 08.0.30 and FastIron 08.0.40, then the auto image copy process cannot copy the image.

When an image mismatch occurs in a traditional stack, the active controller (master unit) copies its own image to the mismatched units. As part of a CB stack, CB units can be updated in the same way. However, in a Campus Fabric domain, the CB and PE require different images. In addition, the PE image cannot be stored on an ICX 7650, ICX 7750, or ICX 7850 stack unit.

To copy the image of a PE in a Campus Fabric domain, the auto image copy process accesses the correct PE image on a TFTP server. If the correct image is found on the server, it is downloaded to the mismatched unit. Once the correct image has been copied, the mismatched unit is reloaded to activate the new image. If more than one PE unit is being updated, all mismatched units are reloaded at the same time. When the auto image copy process is complete, all units are up to date and available.

Commands are provided to configure the TFTP server. If no TFTP server has been configured when a mismatch occurs, you are prompted to provide the IP address for the server. If the server cannot be reached or if the correct image cannot be found on the TFTP server, the system checks for any attached USB drive and updates the mismatched PE unit or units if a PE image is found. Otherwise, the unit or units remain in an image mismatch state until you manually copy the image from an external server.

## Auto Image Copy Considerations

- The process does not execute if the running image and corresponding flash image are not the same.
- The process is not triggered if the major versions of the mismatched units are not the same.
- The process may run more than once if stack units are placed in nonoperational mode at different times.

## Disabling or Re-enabling the Auto Image Copy Process for a Campus Fabric (SPX) Configuration

The auto image copy process is enabled by default but may be disabled.

You can use the **image-auto-copy disable** command to disable automatic image updates if you want to run different software versions on different units of a stack. This can be useful, for example, if you want to try out a RUCKUS patch image on just one unit.

1. Check whether the auto image copy process is enabled by using the **show stack detail** command at the Privileged EXEC level on the stack active controller.

The auto image copy process is disabled in the following **show stack detail** command output for an ICX 7750 traditional stack.

```
ICX7750-48C Router(config)# show stack detail
T=26m23.4: alone: standalone, D: dynamic cfg, S: static
ID   Type           Role      Mac Address   Pri State   Comment
1   S ICX7750-48XGF member  0000.0000.0000  0 reserve
2   S ICX7750-26QXG standby  748e.f8f9.6700  255 remote Ready
3   S ICX7750-48XGC active   cc4e.2438.6a80  255 local  Ready

      standby      active
      +----+      +----+
2/1| 2 |2/4--2/1| 3 |2/4
      +----+      +----+
Standby u2 - No hitless failover. Reason: hitless-failover not configured
Current stack management MAC is cc4e.2438.6a80

Image-Auto-Copy is Disabled.

      Stack Port Status           Neighbors
Unit# Stack-port1      Stack-port2      Stack-port1      Stack-port2
2     dn (2/2/1)         up (2/2/4)       none              U3 (3/2/1)
3     up (3/2/1)         dn (3/2/4)       U2 (2/2/4)       none

Unit# System uptime
2     23 minute(s) 53 second(s)
3     26 minute(s) 23 second(s)
```

2. To re-enable auto image copy, enter the **no image-auto-copy disable** command in global configuration mode on the active controller as shown in the following example.

```
ICX7750-48C Router(config)# no image-auto-copy disable
Image mismatch Auto Copy enabled

SYSLOG: <14> Jan 11 02:51:04 System: Image mismatch Auto Copy Enabled
```

## Configuring a TFTP Server for Campus Fabric (SPX) auto image copy

You can designate a TFTP server from which the auto image copy process downloads the correct PE image to a mismatched unit.

The requisite PE image must be stored on an accessible TFTP server, and the auto image copy process must be enabled for the Campus Fabric domain.

The IP address of the TFTP server can be configured in advance, or you can provide the IP address when prompted during the auto image copy process if it has not been pre-configured.

1. Enter global configuration mode.

```
device# configure terminal
```

2. Run the **tftp-server** command. The following example designates the image location on the server with the IP address 10.70.42.172 in the `builds` folder under the server directory.

```
device(config)# tftp-server 10.70.42.172 image-location /server/builds/
```

## Manual Upgrade of Campus Fabric (SPX) Images Using a Manifest File

Manifest files are prepared for every release. They contain and list all boot, firmware, and application images as well as signature files. A manifest file also specifies a relative directory path to the images.

You can use a manifest file to perform a manual upgrade of the Campus Fabric domain when required, for example, if a major image mismatch is detected or if the auto image copy process has not been configured or could not be executed. Using a single command, you can trigger multiple downloads or image copies and upgrade all core stack and PE units in the Campus Fabric domain.

1. On the active controller, enter the **copy tftp system-manifest** command followed by the IP address of the TFTP server and the name of the manifest file. If you don't specify a partition, the files are copied to both primary and secondary flash.

Copy the image binary files to primary or secondary flash only:

**copy tftp system-manifest** *server-ip-address manifest-filename* [ **primary** | **secondary** ]

```
device# copy tftp system-manifest 10.70.42.172 stage/FI08040_Manifest.txt primary
```

Once the images are installed on the system, you are prompted to reload the system for the new images to take effect.

2. Enter the **write memory** command, followed by a **reload** command.

The specified images are loaded to all Campus Fabric CB and PE units.

## Campus Fabric Management

### Unconfiguring the CB Stack or PE Units

The following example copies the binary image for the FastIron 08.0.40 manifest file to secondary flash from the TFTP server.

```
device# copy tftp system-manifest 10.70.42.172 stage/FI08040_Manifest.txt secondary
device# Flash Memory Write (8192 bytes per dot) .....
DOWNLOADING MANIFEST FILE Done.
device#Flash Memory Write (8192 bytes per dot)
Automatic copy to member units: 3
...
COPY ICX7750 SIGNATURE TFTP to Flash Done
device# Load to buffer (8192 bytes per dot)
Automatic copy to member units: 3
...
SYNCING IMAGE TO FLASH. DO NOT SWITCH OVER OR POWER DOWN THE UNIT(8192 bytes per dot)...
...
Copy ICX7750 from TFTP to Flash Done.
device#Load to buffer (8192 bytes per dot)
Automatic copy to member units: 17 18
...
PLEASE WAIT. MEMBERS SYNCING IMAGE TO FLASH. DO NOT SWITCH OVER OR POWER DOWN THE UNIT...
Copy ICX7450 from TFTP to Flash Done.

Manifest file upgrade done, please reload the system
```

## Unconfiguring the CB Stack or PE Units

The **spx unconfigure** command can be used to convert PE units to regular switches or routers or to remove SPX configuration from all CB and PE units.

### Removing SPX Configuration from PE Units

You can remove SPX configuration from a PE unit locally using the **spx unconfigure me** command. When a PE joins an SPX system, the PE unit's local console is redirected to the CB's console. The PE console returns to its local console if it loses connection to the CB. The **spx unconfigure me** command is only available to a PE local console.

The **spx unconfigure me** command removes the PE startup file from the PE unit on which the command is issued. The startup configuration file for regular mode is not affected. If the PE is in PE mode (with a prompt prefix of [PE]), it reloads. A device in regular mode or in Provisional-PE mode (with a [Provisional-PE] prefix on the prompt) does not reload.

You can also remove PE configuration from the CB using the PE ID in the **spx unconfigure id** command. This form of the command can be entered only from the CB. The command removes the PE startup file of the specified PE and reloads the unit as a switch or router from the regular startup file.

The following example shows system response when the **spx unconfigure me** command is entered on an active PE.

```
[PE]ICX7450-24 Router# spx unconfigure me
This unit will remove the PE startup file and reload as a standalone. Are you sure? (enter 'y' or 'n'): y
remove PE startup file
[PE]ICX7450-24 Router# Halt and reboot from Primary: reason=unconfigure
Sent SIGTERM to all processes
Sent SIGKILL to all processes
Requesting system reboot
Restarting system.

Ruckus Wireless Bootloader: 10.1.06b002T215 (Sep 10 2015 - 06:30:05)

Validate Shmoo parameters stored in flash ..... OK
Restoring Shmoo parameters from flash .....
Running simple memory test ..... OK
ICX7450-24 Copper (Non-POE), P2
SYS CPLD VER: 0x10, Released Ver: 0
```



```
Enter 'b' to stop at boot monitor: 0
bootdelay: ===
Booting image from Primary
.....
.....
...## Booting kernel from Legacy Image at 70000200 ...
  Image Name:      Image
ARM Linux Kernel Image (gzip compressed)
  Data Size:      24091093 Bytes =      Load Address: 61008000
  Entry Point:    61008000
  Verifying Checksum ... OK
  Uncompressing Kernel Image ... OK

Starting kernel ...

SP's eUSB-Infra Called
  Number of eUSB partitions 3 ...
PLATFORM SP
Config partition mounted.
eUSB flash drive is ready
No External USB Drive(s) Mounted .
Creating TUN device
*** Crash dump information is available, please collect it using "supportsave" CLI ***
Starting the FastIron.
FIPS Disabled:PORT NOT DISABLED
platform type 70
OS>Applying factory defaults..
INFO: empty config data in the primary area, try to read from backup
INFO: empty config data in the backup area also
INFO: startup config data is not available, try to read from backup
INFO: startup config data in the backup area is not available
set_board_level: gi_board_type = 98SOC unit 0 attached to PCI device BCM56548_A0
u=0 p=50 Using SDK PHY driver for BCM84756/7/9
u=0 p=51 Using SDK PHY driver for BCM84756/7/9
u=0 p=52 Using SDK PHY driver for BCM84756/7/9
u=0 p=53 Using SDK PHY driver for BCM84756/7/9
Initializing the parallel detect
Setting the CMIC registers for the LINK SCAN
Pre Parsing Config Data ...
INFO: empty config data in the primary area, try to read from backup
INFO: empty config data in the backup area also

Parsing Config Data ...
INFO: empty config data in the primary area, try to read from backup
INFO: empty config data in the backup area also

Hotplugger Daemon Initialized ..
System initialization completed...console going online.
  Copyright (c) 1996-2015 Ruckus Wireless Communications Systems, Inc. All rights reserved.
  UNIT 1: compiled on Nov  2 2015 at 02:36:32 labeled as SPR08040b739
    (24091669 bytes) from Primary SPR08040b739.bin
    SW: Version 08.0.40b739T213
  Compressed Boot-Monitor Image size = 786944, Version:10.1.06T215 (spz10106b002)
  Compiled on Thu Sep 10 13:30:24 2015

HW: Stackable ICX7450-24
Internal USB: Serial #: 9900614021300109
  Vendor: ATP Electronics, Total size = 1919 MB
=====
UNIT 1: SL 1: ICX7450-24 24-port Management Module
  Serial #:CYT3316K00P
  License: ICX7450_L3_SOFT_PACKAGE (LID: eavIIGLmFFr)
  License Compliance: ICX7450-PREM-LIC-SW is Compliant
  P-ASIC 0: type B548, rev 01 Chip BCM56548_A0
=====
UNIT 1: SL 2: ICX7400-4X10GF 4-port 40G Module
  Serial #:CYV3332K034
=====
UNIT 1: SL 3: ICX7400-1X40GQ 1-port 40G Module
  Serial #:CYX3315K03N
=====
```

## Campus Fabric Management

### Unconfiguring the CB Stack or PE Units

```
UNIT 1: SL 4: ICX7400-1X40GQ 1-port 40G Module
Serial #:CYX3315K01P
=====
1000 MHz ARM processor ARMv7 88 MHz bus
8192 KB boot flash memory
2048 MB code flash memory
2048 MB DRAM
STACKID 1 system uptime is 27 second(s)
The system : started=warm start reloaded=by "reload"

ICX7450-24 Router>
Optics detected on 1/2/1
Optics detected on 1/2/2
Optics detected on 1/2/3
Optics detected on 1/4/1

ICX7450-24 Router>
Power supply 1 detected.
Power supply 1 is up.
Stack unit 1 Power supply 1 is up
```

## Removing SPX Configuration from All Units

The **spx unconfigure all** command can be issued only on a CB. This form of the command removes the SPX startup file of every PE and CB unit in the Campus Fabric domain. It also reloads all PE units. The CB unit from which the command is issued and other CB units in the domain are not reloaded.

The following example removes all SPX configuration from all units.

```
ICX7650-48F Router# spx unconfigure all
Will remove all spx unit PE startup files and reload them. Are you sure? (enter 'y' or 'n'): y
Sent unconfigure messages to spx unit 17 18
ICX7650-48F Router#T=3h36m32.3: spx-port 2/1/41 goes down

SYSLOG: <14> Nov  2 12:24:19 System: Interface ethernet 2/1/41, state down
T=3h36m33.4: Active unit 1 deletes u17 but keeps its static config.
delete reason: Port 2/1/41 is down.
T=3h36m33.4: spx-port 17/2/4 goes down
T=3h36m33.4: spx-lag 17/1/1 goes down
T=3h36m33.5: spx-lag 17/1/2 goes down
T=3h36m33.5: Active unit 1 deletes u18 but keeps its static config.
delete reason: Port 2/1/41 is down.
T=3h36m33.5: spx-lag 18/1/1 goes down
T=3h36m33.5: spx-lag 18/1/2 goes down
```

## Removing Stacking Configuration

### NOTE

It is not necessary to remove stacking configuration before enabling a PE unit. However, if stacking is enabled on the unit, it must be disabled before the PE is enabled and configured.

Because PE units do not participate in the stack election process, startup configuration is never synched to these units. As a result, the regular startup configuration file never changes when a PE unit becomes part of a Campus Fabric domain, and the configuration is available later if the PE unit is converted to regular mode.

For more information on unconfiguring a stack unit, refer to the *RUCKUS FastIron Stacking Configuration Guide*.

## CB Stack Merges and Breaks

CB stacks merge and break much like traditional stacks.

### CB Stack Merges

When two CB stacks merge, they behave according to the rules governing stack merges described in the *RUCKUS FastIron Stacking Configuration Guide*. The active controller that loses the new controller election reboots. The PE groups from the losing stack join the winning CB stack, and PE units are initialized.

### CB Stack Breaks

if hitless-failover is enabled and the active controller leaves the CB stack, the standby controller takes over immediately.

When a CB stack breaks, two CB stacks may form if the units that break away include a standby controller. In this case, the standby takes control to form a stack or a standalone. Each stack owns any PE unit directly connected to the stack. Each stack removes any live PE unit that is not linked to the stack. The old active controller for the CB owns any PE unit that has LAG ports connected to both stacks.

Refer to the *RUCKUS FastIron Stacking Configuration Guide* for detailed information on traditional stack breaks and merges.

## Displaying Campus Fabric (SPX) Information

A number of **show** commands simultaneously provide stack and Campus Fabric information, alternate regular mode configuration information for an enabled SPX unit, and detailed information on the entire Campus Fabric domain.

### SPX Information in show running-config Output

The **show running-config** command displays information on any SPX configuration that is present.

Enter **show running-config** at the device level on the active controller of the CB stack to display both stack and SPX information.

The following example shows that a CB is enabled and configured. Stack unit 2 has a connection configured for PE unit 17, with two SPX ports, and PE unit 18, with an SPX port and a two-port LAG. SPX ports and LAGs are configured on both CB stack members. SPX port 1/2/1 has been given the PE group name bld1-floor2. Using the PE group name, the same port has been configured to connect to PE unit 18, if the joining PE matches the configuration shown under SPX unit 18. CB SPX port 2/2/1 has been configured to assign PE ID 20 to a PE that joins on that port.

```
ICX7750-26Q Router# show running-config
Current configuration:
!
ver 08.0.40b1T203
!
stack unit 1
module 1 icx7750-20-qxg-port-management-module
module 2 icx7750-qsfp-6port-qsfp-240g-module
module 3 icx7750-6q-6port-qsfp-240g-module
stack-port 1/2/4
stack unit 2
module 1 icx7750-20-qxg-port-management-module
module 2 icx7750-qsfp-6port-qsfp-240g-module
module 3 icx7750-6q-6port-qsfp-240g-module
stack-port 2/2/4
spx unit 17
module 1 icx7450-24-port-management-module
module 2 icx7400-xgf-4port-40g-module
spx-port 17/3/1
```

## Campus Fabric Management

### Displaying Campus Fabric (SPX) Information

```
spx-port 17/4/1
spx unit 18
module 1 icx7750-20-qxg-port-management-module
module 2 icx7750-qsfp-6port-qsfp-240g-module
module 3 icx7750-6q-6port-qsfp-240g-module
spx-lag 18/1/9 to 18/1/10
spx-port 18/2/4
stack enable
stack mac cc4e.2438.7280
!
!
spx cb-enable
spx cb-config
spx-port 1/1/10
spx-port 1/2/1 pe-group bld1-floor2
spx-port 2/2/1
spx-lag 1/1/15 1/1/17 to 1/1/18 pe-group engineering
spx-lag 2/1/10 to 2/1/11 2/1/15
pe-id bld1-floor2 18
spx pe-id 2/2/1 20
!
```

## SPX Information in show configuration Command Output

In regular switch or router mode, the **show configuration** command shows the saved startup configuration. In PE or Provisional-PE mode, the **show configuration** command shows the configuration in the PE startup file for the unit.

### NOTE

To view the startup configuration that the unit would have in regular mode (as a switch or router), use the **show startup-config** command instead.

The following example shows the configuration for a provisional PE that has been enabled with the **spx pe-enable** command.

```
[Provisional-PE]ICX7450-48F Router# show configuration
Configuration in PE startup file:
!
ver 08.0.40b1T213
!
spx pe-enable
spx unit 1
module 1 icx7450-48f-sf-port-management-module
module 2 icx7400-xgf-4port-40g-module
module 4 icx7400-qsfp-1port-40g-module
spx-lag 1/2/1 to 1/2/2
spx-port 1/2/4
```

## Displaying Regular Mode Configuration from a PE Unit

The **show startup-config** command displays the configuration a PE or provisional PE would have in regular mode as a switch or router.

The following example displays the configuration this active PE would have if it were returned to regular mode.

```
[PE]ICX7450-24 Router# show startup-config
*** display startup configuration used in switch/router (not PE) ***
!
Startup-config data location is flash memory
!
Startup configuration:
!
ver 08.0.40b739T213
!
stack unit 1
  module 1 icx7450-24-port-management-module
  module 2 icx7400-xgc-4port-40g-module
  module 3 icx7400-qsfp-1port-40g-module
```

```

module 4 icx7400-qsfp-1port-40g-module
!
!
interface management 1
ip address 10.20.226.194 255.255.255.0
!
interface ethernet 1/2/1
speed-duplex 10G-full
!
interface ethernet 1/2/2
speed-duplex 10G-full
!
interface ethernet 1/2/3
speed-duplex 10G-full
!
interface ethernet 1/2/4
speed-duplex 10G-full
!
!
End

```

#### NOTE

To view the configuration stored in the PE startup file, use the **show configuration** command instead. The **show configuration** command can also be used in regular mode to show the saved startup configuration.

## Displaying Information with the show spx Command

Enter the **show spx** command on the active controller to display information on the Campus Fabric topology.

The **show spx** command output in the following example shows a two-member ICX 7750 CB stack with one attached ICX 7450 PE unit, PE 17. The command was entered on the active controller, and the second stack member is available to take over as the standby.

```

ICX7750-26Q Router# show spx
T=3h24m20.3: alone: standalone, D: dynamic cfg, S: static
ID Type          Role    Mac Address  Pri  State Comment
1 S ICX7750-26QXG active  cc4e.2438.7280 0   local  Ready
3 S ICX7750-26QXG standby 748e.f8f9.6300 0   remote Ready
17 S ICX7450-48GF spx-pe  cc4e.246c.f190 N/A remote Ready
active          standby
+----+         +----+
| 1 |2/4--2/1| 3 |
+----+         +----+
                    +-----+
1/1/5--4/1| 17 |
                    +-----+

```

Enter the **show spx** command on a PE unit to display local information as shown in the following example. The "S" after the PE ID (17) indicates that the configuration for this PE has been saved (is "static").

```

[PE]rconsole-17@ICX7450-48F Router# show spx
T=53m13.0: alone: standalone, D: dynamic cfg, S: static
ID Type          Role    Mac Address  Pri  State Comment
17 S ICX7450-48GF spx-pe  cc4e.246c.f190 N/A remote Ready
+----+
-4/1| 17 |
+----+

```

You can add a parameter to the **show spx** command to display information about different aspects of the Campus Fabric topology.

```

ICX7750-26Q Router# show spx ?
cb-port          Displays PEs attached to this port
connections      Displays PE port to port connectivity
csp              Displays CSP information
debug            Displays SPX Debug commands
lag              Displays spx-lag information

```

## Campus Fabric Management

### Displaying Campus Fabric (SPX) Information

```
mecid          Displays Dot1br Multicast ECID information
multicast      Multicast related information
pe-group       Displays PEs in a pe group
pe-id          Displays this PE
ring           SPX Ring infra information
status PE      Displays operational status and detachments for a specific PE unit
zero-touch ipc Displays statistics for zero-touch ipc
zero-touch log Displays internal zero-touch log
zero-touch status Displays current zero-touch status
```

Enter the **show spx cb-port** command to display a list of PE units attached to the port.

```
ICX7750-48F Router# show spx cb
cb-port        Displays PEs attached to this port
ICX7750-48F Router# show spx cb-port 2/1/7
Show PEs attached to a CB port 2/1/7
T=3h46m16.0: alone: standalone, D: dynamic cfg, S: static
ID  Type      Role      Mac Address  Pri State  Comment
1   S ICX7750-48XGF active     cc4e.2438.7e80 128 local  Ready
2   S ICX7750-48XGF standby   cc4e.246e.cd80 128 remote Ready
19  S ICX7450-24G  spx-pe   cc4e.246c.e420 N/A remote Ready
```

```
standby      active
+----+      +----+
2/4| 2 |2/1--2/1| 1 |2/4
+----+      +----+

+-----+
2/1/7--2/3| 19 |
+-----+
```

```
ICX7750-48F Router#
```

Enter the **show spx mecid** command to display Multicast E-CID (ME-CID) information for the Campus Fabric domain.

The following example uses the keyword **allocated** to display information on allocated ME-CIDs.

```
ICX7750-48F Router# show spx mecid allocated
FSM-State : CREATE_P - created TX Pending, DELETE_P - deleted TX Pending
            DELETE_AW - Ack Waiting, CREATED - Stable State
Total MECID Allocated 2
-----
SNo  MECID PEs VPs AW State      Shr Elements
-----
1    4096 3   114 0  CREATED    No {17/1/1 17/1/2 17/1/3 17/1/4 17/1/5 17/1/6 17/1/7 ...}
2    4097 3   11  0  CREATED    No {17/1/1 17/1/2 17/1/3 17/2/3 17/2/4 18/1/1 18/1/2 ...}
```

The following command shows information for a specific ME-CID (4096).

```
ICX7750-48F Router# show spx mecid 4096
MECID State : CREATE_P - created Tx Pending, DELETE_P - deleted Tx Pending
            DELETE_AW - Ack Waiting, CREATED - Stable State
VP State    : ADD_P - Added Tx Pending, REMOVE_P - Removed Tx waiting
            : ADDED - Stable State
MECID: 4096 Total PEs: 3, Epoch: 0, FSM State: CREATED, SetId: 0x0, AW: 0
1. PE: 17, Total VPs: 54, Ack_waiting: 0, CP Added: Yes
   (17/1/1 (cp) ADDED), (17/1/2 (cp) ADDED), (17/1/3 (cp) ADDED), (17/1/4 ADDED), (17/1/5 ADDED),
   (17/1/6 ADDED), (17/1/7 ADDED), (17/1/8 ADDED), (17/1/9 ADDED), (17/1/10 ADDED),
   (17/1/11 ADDED), (17/1/12 ADDED), (17/1/13 ADDED), (17/1/14 ADDED), (17/1/15 ADDED),
   (17/1/16 ADDED), (17/1/17 ADDED), (17/1/18 ADDED), (17/1/19 ADDED), (17/1/20 ADDED),
   (17/1/21 ADDED), (17/1/22 ADDED), (17/1/23 ADDED), (17/1/24 ADDED), (17/1/25 ADDED),
   (17/1/26 ADDED), (17/1/27 ADDED), (17/1/28 ADDED), (17/1/29 ADDED), (17/1/30 ADDED),
   (17/1/31 ADDED), (17/1/32 ADDED), (17/1/33 ADDED), (17/1/34 ADDED), (17/1/35 ADDED),
   (17/1/36 ADDED), (17/1/37 ADDED), (17/1/38 ADDED), (17/1/39 ADDED), (17/1/40 ADDED),
   (17/1/41 ADDED), (17/1/42 ADDED), (17/1/43 ADDED), (17/1/44 ADDED), (17/1/45 ADDED),
   (17/1/46 ADDED), (17/1/47 ADDED), (17/1/48 ADDED), (17/2/1 ADDED), (17/2/2 ADDED),
   (17/2/3 ADDED), (17/2/4 ADDED), (17/3/1 ADDED), (17/4/1 ADDED),
2. PE: 18, Total VPs: 30, Ack_waiting: 0, CP Added: No
   (18/1/1 ADDED), (18/1/2 ADDED), (18/1/3 ADDED), (18/1/4 ADDED), (18/1/5 ADDED),
```

```
(18/1/6 ADDED), (18/1/7 ADDED), (18/1/8 ADDED), (18/1/9 ADDED), (18/1/10 ADDED),
(18/1/11 ADDED), (18/1/12 ADDED), (18/1/13 ADDED), (18/1/14 ADDED), (18/1/15 ADDED),
(18/1/16 ADDED), (18/1/17 ADDED), (18/1/18 ADDED), (18/1/19 ADDED), (18/1/20 ADDED),
(18/1/21 ADDED), (18/1/22 ADDED), (18/1/23 ADDED), (18/1/24 ADDED), (18/2/1 ADDED),
(18/2/2 ADDED), (18/2/3 ADDED), (18/2/4 ADDED), (18/3/1 ADDED), (18/4/1 ADDED),
```

```
3. PE: 19, Total VPs: 30, Ack_waiting: 0, CP Added: No
(19/1/1 ADDED), (19/1/2 ADDED), (19/1/3 ADDED), (19/1/4 ADDED), (19/1/5 ADDED),
(19/1/6 ADDED), (19/1/7 ADDED), (19/1/8 ADDED), (19/1/9 ADDED), (19/1/10 ADDED),
(19/1/11 ADDED), (19/1/12 ADDED), (19/1/13 ADDED), (19/1/14 ADDED), (19/1/15 ADDED),
(19/1/16 ADDED), (19/1/17 ADDED), (19/1/18 ADDED), (19/1/19 ADDED), (19/1/20 ADDED),
(19/1/21 ADDED), (19/1/22 ADDED), (19/1/23 ADDED), (19/1/24 ADDED), (19/2/1 ADDED),
(19/2/2 ADDED), (19/2/3 ADDED), (19/2/4 ADDED), (19/3/1 ADDED), (19/4/1 ADDED),
```

The following example shows a summary of configuration options and statistics on ME-CID activity in the Campus Fabric domain.

```
ICX7750-48F Router# show spx mecid summary
Manager Init      : Yes           Replication Group Sharing : No
Use PE CSP for TX : Yes           Epoch                       : 0
Reconciliation Pass : 0           Replication Id             : 0
ECID Partition    : Enabled       Global Timer running      : No
ECID sharing      : No
DEFAULT          4096 16383 12288 LRU
SWITCHING        4096 8191 4096 ACENDING
ROUTING          8192 16383 8192 DECENDING
```

	alloc	in-use	avail	get-fail	limit	get-mem	size	init
MECID info	1000	2	998	0	232000	3	66	1000
PE info	400	6	394	0	92800	12	52	400
VP info	10000	125	9875	0	2320000	255	32	1000
TX Q	1000	0	1000	0	232000	31	12	1000
PE Msg	1024	0	1024	0	237568	78	56	1024

Total memory in used: 476144 bytes

```
ICX7750-48F Router#
ICX7750-48F Router# show spx mecid topology
Total Cascade Port (CP): 2
1. CP-TR(e2/1/41) :-->[e17/2/4]PE_17[TR(e17/1/1)]-->[TR(e18/1/1)]PE_18
2. CP-TR(e2/1/7) :-->[e19/2/3]PE_19
```

Enter the **show spx pe-group** command followed by the group name to display a list of PE units in a PE group.

```
ICX7750-48F Router# show spx pe-group GROUP1
Show PEs attached to pe-group GROUP1 (port 2/1/41)
T=17h57m5.5: alone: standalone, D: dynamic cfg, S: static
ID Type Role Mac Address Pri State Comment
1 S ICX7750-48XGF active cc4e.2438.7e80 128 local Ready
2 S ICX7750-48XGF standby cc4e.246e.cd80 128 remote Ready
17 S ICX7450-48P spx-pe cc4e.248b.da60 N/A remote Ready
18 S ICX7450-24G spx-pe cc4e.246c.e3f8 N/A remote Ready
```

```

standby      active
+----+      +----+
2/4| 2 |2/1--2/1| 1 |2/4|
+----+      +----+

+----+      +----+
2/1/41--2/4| 17 |1/1==1/1| 18 |
+----+      +----+
```

Enter the **show spx pe-id** command followed by the PE number to display information for a specific PE.

```
ICX7750-48F Router# show spx pe-id 17
Show the sub-stack containing spx unit 17
T=3h51m3.8: alone: standalone, D: dynamic cfg, S: static
ID Type Role Mac Address Pri State Comment
1 S ICX7750-48XGF active cc4e.2438.7e80 128 local Ready
2 S ICX7750-48XGF standby cc4e.246e.cd80 128 remote Ready
17 S ICX7450-48P spx-pe cc4e.248b.da60 N/A remote Ready
```

## Campus Fabric Management

Displaying Campus Fabric (SPX) Information

```
18 S ICX7450-24G spx-pe cc4e.246c.e3f8 N/A remote Ready
```

```
standby      active
+----+      +----+
2/4| 2 |2/1--2/1| 1 |2/4
+----+      +----+

+----+      +----+
2/1/41--2/4| 17 |1/1==1/1| 18 |
+----+      +----+
```

Enter the **show spx pe id status** command to display the operational status and detachment history for a particular PE unit.

```
ICX7750-48F Router# show spx pe 17 status
```

PE-ID	operational-status	Detach-count	Last-detached-time
17	UP	1	00:00:25.282 GMT+00 Wed Jul 31 2019

Enter the **show spx ring** command with the desired parameter to show information for a specific ring, for all rings, or for PE chains in the Campus Fabric domain.

The following example displays all rings in the Campus Fabric domain.

```
ICX7750-48F Router# show spx ring all
```

Ring Id	FSM State	CB port	Lag	Remote CB port	Lag	Log Block Link
1	ACTIVE	1/1/2	3072	1/1/3	3073	PE29x--xCB1/1/3
2	ACTIVE	3/1/19	3076	3/1/45	3078	CB3/1/19x--xPE26
3	ACTIVE	2/1/12	3075	3/1/31	3077	PE27x--xPE28
4	ACTIVE	1/1/5	3079	2/1/9	3074	PE19x--xPE20

The following example displays information for a specific ring. Ring IDs can be derived from the **show spx ring all** command.

```
ICX7750-48F SPX# show spx ring 2
```

Ring Id	FSM State	CB port	Lag	Remote CB port	Lag	Log Block Link
2	ACTIVE	3/1/19	3081	3/1/45	3083	PE26x--xPE25

CB chains Information:

CB Port	Lag	Epoch	Ring	Id	FSM State	Remote CB port	Lag	Chain
3/1/19	3081	75	YES	2	ACTIVE	3/1/45	3083	PE26x--xPE25

PE chain information connecting to CB port 3/1/19 [Lag 3081]

PE Id	Epoch	FSM state	Uplink port	Casc port	Log Block	Prev PE	Next PE
PE26	75	ACTIVE	26/2/2	26/4/1	YES	--	x--x

PE chain information connecting to remote CB port 3/1/45 [Lag 3083]

PE Id	Epoch	FSM state	Uplink port	Casc port	Log Block	Prev PE	Next PE
PE25	75	ACTIVE	25/2/1	25/3/1	YES	--	x--x



The following example shows output for all PE chains in the Campus Fabric domain.

```
ICX7750-48F SPX# show spx ring chain
```

```
-----
                        SPX CB [CASC PORT] CHAINS
-----
```

CB Port	Lag	Epoch	Ring	Id	FSM State	Remote CB port	Lag	Chain
1/1/2	3072	75	YES	3	ACTIVE	1/1/3	3073	PE23--PE24x--xPE29
1/1/3	3073	75	YES	3	ACTIVE	1/1/2	3072	PE29x--xPE24--PE23
2/1/12	3079	75	YES	1	ACTIVE	3/1/31	3082	CB2/1/12x--xPE27--PE28
3/1/3	3080	75	YES	4	ACTIVE	1/1/5	3084	PE22--PE21--PE20--PE19--PE18--PE17x--xCB1/1/5
3/1/19	3081	75	YES	2	ACTIVE	3/1/45	3083	PE26x--xPE25
3/1/31	3082	75	YES	1	ACTIVE	2/1/12	3079	PE28--PE27x--xCB2/1/12
3/1/45	3083	75	YES	2	ACTIVE	3/1/19	3081	PE25x--xPE26
1/1/5	3084	75	YES	4	ACTIVE	3/1/3	3080	CB1/1/5x--xPE17--PE18--PE19--PE20--PE21--PE22

The following example shows output for a specific PE chain (connected to CB port 3/1/19) in the Campus Fabric domain.

```
ICX7750-48F SPX# show spx ring chain 3/1/45
```

```
-----
```

CB Port	Lag	Epoch	Ring	Id	FSM State	Remote CB port	Lag	Chain
3/1/45	3083	75	YES	2	ACTIVE	3/1/19	3081	PE25x--xPE26

```
-----
PE chain information connecting to CB port 3/1/45 [Lag 3083]
-----
```

PE Id	Epoch	FSM state	Uplink port	Casc port	Log Block	Prev PE	Next PE
PE25	75	ACTIVE	25/2/1	25/3/1	YES	--	x--x

```
-----
PE chain information connecting to remote CB port 3/1/19 [Lag 3081]
-----
```

PE Id	Epoch	FSM state	Uplink port	Casc port	Log Block	Prev PE	Next PE
PE26	75	ACTIVE	26/2/2	26/4/1	YES	--	x--x

Enter the **show spx csp** command followed by desired parameters and the PE units you for which you want to display Control and Status Protocol (CSP) information that can help in troubleshooting issues. The information displayed is derived from the CB.

Enter the **show spx csp distributed** command followed by the PE units from which you want to receive information to display CSP information directly from the PE or PEs specified.

The following example shows CSP information received directly from PE units 23 and 29 as indicated by the use of the keyword **distributed** on the command line.

```
ICX7750-48F Router# show spx csp distributed units 23 29
```

```
*****
Response from PE 23:
*****

CSP Oper: yes, Attach time: 1m22.0, up time: 11 hour(s) 48 minute(s) 38 second(s)
PE Spx Lag id: 2, cur state up, IPC/ECP Port: 23/2/3
Number of Traffic Class: 8
Priority Flow Control: no
CSP control ECID handshake complete: yes
CSP control ECID: 555
CSP Alternate control ECID: 556
PE is in Ring (Status: Active), Logical Block: 1
Total number of configured ports: 566
CSP number of create port requests sent: 54
CSP last Tx Trans ID=3, last Rx Trans ID=6
ECP txErrors=0, sequence=10 firstSeq=10 lastSeq=9 firstAckIdx=0 ackIdx=0
Next PE: None
```

## Campus Fabric Management

### Displaying Campus Fabric (SPX) Information

```
Previous PE: None
Local CSP Major version is 1 Minor version 1
Peer CSP Major version is 1 Minor version 1
Oper CSP Major version is 1 Minor version 1
```

```
*****
Response from PE 29:
*****
```

```
CSP Oper: yes, Attach time: 1m13.6, up time: 11 hour(s) 48 minute(s) 44 second(s)
PE Spx Lag id: 2, cur state up, IPC/ECP Port: 29/2/3
Number of Traffic Class: 8
Priority Flow Control: no
CSP control ECID handshake complete: yes
CSP control ECID: 1035
CSP Alternate control ECID: 1036
PE is in Ring (Status: Active), Logical Block: 0
Total number of configured ports: 566
CSP number of create port requests sent: 54
CSP last Tx Trans ID=3, last Rx Trans ID=9
ECP txErrors=0, sequence=13 firstSeq=13 lastSeq=12 firstAckIdx=0 ackIdx=0
Next PE: None
Previous PE: None
Local CSP Major version is 1 Minor version 1
Peer CSP Major version is 1 Minor version 1
Oper CSP Major version is 1 Minor version 1
```

Enter the **show spx zero-touch status** command to check whether Campus Fabric Zero-touch provisioning is enabled, active, or available.

The following example shows command output for a CB unit. The output indicates that both Campus Fabric (SPX) and zero-touch provisioning have been enabled. Two valid chains have been discovered, and three attached units have been added as PEs. IPC-over-Ethernet and ACL are used to copy new images to new units before reloading them as PEs if the new units have different images.

```
ICX7750-26Q Router# show spx zero-touch status
I cannot be discovered by zero-touch or spx interactive-setup. reason: cannot be a PE
zero-touch-enable and spx cb-enable are configured. Have done 19 probes
ZTP has discovered 2 valid chains and converted 3 PEs.
zero-touch-enable period: 3 minutes. Will trigger in 2 min 45 sec
ZTP postponed due to topology changes: 2
My MAC used in the IPC-over-Ethernet is 748e.f8f9.636e.
ACL #=0, ind=0
```

The following example shows output from a new unit. Neither SPX interactive-setup or zero-touch provisioning is in progress.

```
ICX7250-24 Router# show spx zero-touch status
I can be discovered by zero-touch or spx interactive-setup.
zero-touch-enable is not configured.
I am not assigned any PE ID
ACL #=0, ind=0
```

The following example shows output from a new unit during the image copy process. The referenced ACLs are used to forward image download packets. For example, packets with the destination MAC of 609c.9f2a.981c are forwarded to port 2/5. The lines " My MAC used in image copy is 609c.9f04.68cf " and "609c.9f04.68cf me cpu" shows that this MAC is its own MAC, so packets sent to this MAC are trapped to CPU.

```
ICX7250-24 Router# show spx zero-touch status
I can be discovered by zero-touch or spx interactive-setup.
I am discovered by CB u2 748e.f8f9.6300. My assigned ID is 28.
Will clean up in 116.6 sec if no keep-alive. Recv last KA 3.4 sec ago.
zero-touch-enable is not configured.
Default deny-all ACL is installed
My MAC used in image copy is 609c.9f04.68cf.
CB is in image download mode.
ID=28 MAC=609c.9f04.68ac ZTP=1, D0=2/5 2/6 2/7 2/8 D1=2/1 2/3 2/4
ACL #=7, ind=7
0: 609c.9f04.68cf me cpu
1: 609c.9f2a.d49c fwd 2/5 i=0
2: 609c.9f2a.981c fwd 2/5 i=1
3: 609c.9f04.6fb3 fwd 2/5 i=2
4: 609c.9f04.5e8b fwd 2/1 i=3
```

```
5: cc4e.246c.f1cc fwd 2/1 i=4
6: 748e.f8f9.636e CB fwd 2/1 i=5
Can reach CB u2: MAC=748e.f8f9.636e port=1/2/1
```

The following example shows output from a standalone ICX 7450 with startup configuration flash memory. As indicated in command output, the unit can be converted to a PE using option 3 of the **spx interactive-setup** command.

```
ICX7450-48F Router# show spx zero-touch status
I cannot be discovered by zero-touch or spx interactive-setup option 2. reason: once had startup-
configuration flash
I can be discovered by spx interactive-setup option 3.
zero-touch-enable is not configured.
```

Enter the **show spx zero-touch ipc** command to display statistics on packets used in the zero-touch or spx interactive-setup process.

Check the following output fields:

- **Send message types:** The type 4 (ZTP-request) count should not be 0. If the count is 0, check that the candidate PE units are connected to CB SPX ports or SPX LAGs, zero-touch ports, or to PE ports that are non-base module ports.
- **Recv message types:** If type 3 (ZTP probe) count is 0, check that the candidate PEs are clean units. When it receives a ZTP request or probe, the PE console prints a warning message if it is not qualified.
- **Reliable mail, target MAC:** The send count and success count should match. If they are not equal, some messages have not been acknowledged after repeated retransmission. In this situation, zero-touch or SPX interactive-setup may still be successful.
- **Possible errors:** Check for system information on possible errors, such as corrupted packets.

The following example displays zero-touch IPC information.

```
ICX7750-26Q Router# show spx zero-touch ipc
V2, , src=748e.f8f9.6300, max_pkt_size=1468, rcv 38, send 34
Message types have callbacks:
 3: ZTP-probe                4: ZTP-request
 5: unreliable-mail          6: reliable-mail
 7: test ipc packets         8: cmd-to-new-unit
 9: KA-new-unit

Send message types:
 [4]=30, [6]=4,
Recv message types:
 [3]=30, [6]=8,

Statistics:
 send pkt num      :      34,   send pkt-msg num      :      34,
 rcv pkt num       :      38,   send msg num         :      34,
 rcv msg num       :      38,   pkt buf alloc        :      34,

Reliable-mail      send  success  receive  duplic  T-ms
target MAC         2         2         0        0        3
unrel target MAC   0         0         0         0         0

Possible errors:
```

Enter the **show spx zero-touch log** command to display detailed information on zero-touch-enable and spx interactive-setup processes. Search for **Error!** or **Warning!** messages for details on potential problems.

The following example indicates that port 1/1/47 links to an invalid chain that already contains a maximum number of PE units. The output also indicates a ZTP reliable mail message has not been delivered.

```
ICX7750-26Q Router# show spx zero-touch log
42.4516 ZTP chg_cb(old=0, new=4): I new-A, ZTP not enabled, , 1U 0P A4S0 I4A 1%
8m42.4057 init_zero_touch() init_T=5217 , 3U 0P A4S2 I4A 81%
9m46.4440 Send ZTP probes: u1, ports: 4/1/6 to 4/1/8 PEs: , 3U 0P A4S2 I4A
10m7.5115 cb_r_probe. rec#=2, load=173, inv [0] cc4e.248b.77b0, rec#=2, exist mac=cc4e.246c.f190 <= cc4e.
248b.77b0,
cannot overwrite, 3U 0P A4S2 I4A
21m38.4824 ZTP, 12 .5min T, cb_state = 0, diff = 201 s, diff=201 > 120 sec, trigger probe, 3U 1P A4S2 I4A
```

## Campus Fabric Management

Displaying Campus Fabric (SPX) Information

```
20%
21m38.6988 Send ZTP probes: u1, ports: 4/1/6 to 4/1/8 PEs: pe19, , 3U 1P A4S2 I4A
28m40.3054 *** Error! 1/1/47 links to an invalid chain: (chain length=1 + PE 21 len 5 + PE 31 len 1) = 7 >
max 6
, 3U 0P A4S2 I4A 90%
28m42.4057 *** Warning! ZTP rel_mail fail: chain 0 type=8, len=102, CPU=90%, 3U 0P A4S2 I4A 90%
```

## Using show commands for Operational Analysis

The **show spx connections** command provides information on point-to-point connections to help analyze the Campus Fabric domain. The **show spx-mon** command helps to diagnose and correct a variety of issues.

The **show stack connection** command can be used to show stack cable connections. Likewise, in a Campus Fabric domain, the **show spx connections** command provides comprehensive information on physical connections, which eliminates the need to trace cables manually in the switch room.

Enter the **show spx connections** command in Privileged EXEC mode to display information on point-to-point Campus Fabric connections.

The following example displays information on six SPX connections that form three two-port LAGs. The port connections for each LAG are provided. Based on the connections displayed, three PE units (17, 18, and 19) are connected to the CB. PE units 17 and 18 form a chain. PE unit 19 is connected directly to the CB and has no downstream units.

```
ICX7750-48F Router# show spx connections
Probing the topology. Please wait ...
Spx-interface probe results: 6 links

Link 1: lag, # of ports = 2
1: 1/1/1 <----> 17/2/1
2: 2/1/1 <----> 17/2/2

Link 2: lag, # of ports = 2
1: 17/1/1 <----> 18/1/47
2: 17/1/2 <----> 18/1/48

Link 3: lag, # of ports = 2
1: 1/1/5 <----> 19/2/1
2: 2/1/5 <----> 19/2/2
```

Using the **show spx-mon** command, you can diagnose a variety of operational issues, including PE configuration mismatch, image mismatch, excessive SPX port traffic, and numerous PE join problems. For detailed information on using SPX monitoring capabilities to analyze issues, refer to [Enabling and Using SPX Monitoring](#) on page 153 in this guide.

With **spx-mon** enabled, enter the **show spx-mon** command in Privileged EXEC or global configuration mode to display detailed system information.

The following example enables spx-mon and displays information on the Campus Fabric configuration. Two PE units are in Ready state, and one PE has reserved configuration only. CLI guidance is given to troubleshoot a potential pe-join issue with the third PE unit.

```
ICX7750-48F Router# spx-mon enable
ICX7750-48F Router# show spx-mon

spx-mon is enabled

Total 2 PE(s) attached
Number of PEs in Ready State      : 2 (Id(s): 17, 23)
Number of PEs in Reserve         : 1 (Id(s): 18)    <-- Reserved configuration for 1 PE
Number of PEs in Config-mismatch : 0
Number of PEs in Image-Mismatch  : 0

CLI: sh spx-mon pe-join <cb-cport> can be used to diagnose pe-join issues <-- CLI help for additional
diagnosis

Active CPU Utilization
1 sec avg 1 percent busy
5 sec avg 1 percent busy
60 sec avg 1 percent busy
300 sec avg 1 percent busy

PE CPU Utilization:      Normal
Spx Interface Utilization: Very low
Spx Interface Errors:    None
PE User Port Errors:     None
```

## Campus Fabric mirroring overview

Port mirroring and monitoring involves the following configuration steps:

- Configure mirroring ports.
- Configure ports to be monitored.
- Connect or configure network analyzer to the mirror port and view packets.

Campus Fabric ports can be mirrored and monitored much like stacking ports. The following section describes supported and unsupported Campus Fabric mirroring configurations and provides some basic examples. For more information on FastIron mirroring and monitoring capabilities, including additional configuration examples, refer to "Port mirroring and monitoring" in the *RUCKUS FastIron Monitoring Configuration Guide*.

## Mirroring in a Campus Fabric domain

In a Campus Fabric domain, you can mirror ports in an ICX 7150 PE unit, an ICX 7250 PE unit, an ICX 7450 PE unit, or an ICX 7650, ICX 7750, or ICX 7850 CB unit. Campus Fabric supports port mirroring, VLAN mirroring, and ACL mirroring with a mirror clause.

### *Campus Fabric mirroring limitations*

Consider the following items when configuring mirroring in a Campus Fabric network.

- Only one mirror port can be configured on a PE unit for port mirroring.
- When an SPX LAG is mirrored, all traffic is monitored. It is not possible to limit monitoring to an individual LAG port.
- Due to a hardware limitation, a PE mirror port cannot mirror egress flooding, for example, from broadcast, unknown unicast, or multicast traffic.
- A VLAN must have at least one port member configured before monitoring can be configured.
- All incoming traffic (tagged and untagged) in the VLAN is mirrored. Mirroring is not affected by the configuration of the mirror port itself.

**NOTE**

If you are mirroring outbound traffic on a CB port, you may see additional mirrored traffic incoming on a VLAN that contains PE ports. This happens because CB units flood BUM traffic on all CB ports when inbound traffic is received in a VLAN that contains PE ports. The CB units use an outbound VLAN filter to prevent the flooded traffic from exiting through ports that do not belong to the correct VLAN. However, the outbound traffic is mirrored before the CB's VLAN filter is applied. Traffic will be dropped on CB ports if they are not members of the VLAN, but the mirrored traffic will not be dropped. Outbound mirroring of the CB port will continue as long as it is enabled.

### **Supported Campus Fabric mirroring scenarios**

The following mirroring scenarios are possible in a Campus Fabric domain :

- Mirroring a port on any CB unit, monitoring from any CB port on any CB unit
- Mirroring a CB port, monitoring from a PE port (supported for port-based mirroring; not supported for ACL mirroring)

**NOTE**

If you are monitoring a CB port from a PE port, the monitoring port is configured as a virtual PE port on the CB, and traffic is transmitted to and from the virtual port with an E-tag addressed to the port. Packets are copied out to the mirroring port with the E-tag intact. As a result, the monitoring device receive packets containing the E-tag.

- Mirroring a port on a PE unit, monitoring from another port on the same PE unit
- Mirroring of a CB port, monitoring from a PE port when VLAN mirroring is enabled.

### **Unsupported Campus Fabric mirroring configurations**

The following scenarios are not supported in a Campus Fabric domain:

- Mirroring a port on one PE unit, monitoring a port from a different PE unit

**NOTE**

If the CB determines the mirror port is configured on a PE port, and the monitoring port is on a different PE, the system blocks the configuration and displays a warning similar to the following message:

```
Mirror port 17/1/1 and monitor port 18/1/2 are not on the same PE. Either move mirror port to a CB port, or change mirror and monitor port to the same PE.
```

- With ACL mirroring, PE to CB or CB to PE monitoring
- With VLAN mirroring, PE cannot be used as a mirror port
- Monitoring an individual SPX LAG member

### **Sample configuration for Campus Fabric mirroring**

The following example configures port 1/1/7 on the CB as a mirror port that monitors inbound traffic on PE port 17/1/1.

```
device# configure terminal
device(config)# mirror-port ethernet 1/1/17
device(config)# interface ethernet 17/1/1
device(config-if-pe-e1000-17/1/1)# monitor ethernet 1/1/17 in
```

## Displaying Campus Fabric mirroring information

The **show mirror** command can be used to display information on mirroring activity for the device. The following example displays information on mirroring on CB units 1 and 2. PE units 17 and 18 are being monitored.

```
device# show mirror
Mirror port 1/1/17
  Input monitoring      : (U17/M1)  1   2   3  11
  Input monitoring      : (U17/M2)  1
  Output monitoring     : (U17/M1)  1   2   3  11
  Output monitoring     : (U17/M2)  1
Mirror port 2/1/20
  Input monitoring      : (U17/M1)  10
  Input monitoring      : (U18/M1)   1
  Output monitoring     : (U17/M1)  10
  Output monitoring     : (U18/M1)   1
```

## MIB support for Campus Fabric 802.1br SPX configurations

All statistics about packets received and sent, RMON, jumbo frames (greater than 1518 bytes), runts, giants, and other instances are gathered through the stack interfaces between CB units or through the SPX interfaces between CB units and PE units. These statistics are accessible through SNMP on CB units. MIB support for SPX configuration is the same as for a standard interface. The SPX MIB definition is described in the *Unified IP MIB Reference*.





# Campus Fabric Troubleshooting

---

- [Enabling and Using SPX Monitoring.....](#) 153
- [Troubleshooting PE Data Ports.....](#) 162
- [Campus Fabric General Troubleshooting Checklist.....](#) 164

## Enabling and Using SPX Monitoring

Enable SPX monitoring to use background and system trace information for problem diagnosis and resolution.

SPX monitoring (spx-mon) capabilities are available only in an 802.1br Campus Fabric domain.

Use SPX monitoring tools to help you determine the source of an issue in the Campus Fabric domain, whether the issue stems from a configuration error or system problems. Output from the **show spx-mon** command highlights issues and provides possible next steps to resolve the issues.

From the CB active controller, SPX monitoring checks for the following common issues in the Campus Fabric domain:

- New PE units: The system message indicates that executing the **write memory** command is required.
- PE state: "Ready" indicates that the PE has successfully joined the CB.
- PE units with configuration mismatch: The system displays steps needed to correct the problem.
- PE units with image mismatch: The system lists steps to correct the condition (for example, enable autcopy or configure the TFTP server).
- Current CPU utilization: CPU utilization is listed for the active controller, and, if CPU utilization on the standby controller or any PE unit exceeds 50 per cent, updates are included.
- Port utilization: For each PE, the system indicates the SPX port with the highest utilization.
- SPX port errors: Any PE SPX port errors are listed. For each PE, the SPX port with the highest error count is also listed.
- PE user port errors: Any PE user ports with errors are listed. For each PE, the user port with the highest utilization is also listed.
- SPX port state: The system checks PE port state against CB port state.
- PE chain or ring state: The system lists the members of a chain, the CB SPX port connection, and whether the connection is active.
- PE ring ACL state: The system displays whether the PE ring has passed ACL verification.

Some other items that SPX monitoring can diagnose include:

- PE-to-PE port consistency between the active and standby controllers
- SPX port hardware configuration
- SPX LAG hardware configuration
- CB-PE topology database
- PE forwarding entries
- SPX port VLAN configuration
- SPX port spanning tree state
- Virtual ports for all PE ports
- PE join validation.

Perform the following steps to enable and use SPX monitoring features.

1. In global configuration mode on the CB, enter the **enable spx-mon** command.

```
ICX7750-26Q# configure terminal
ICX7750-26Q(config)# enable spx-mon
```

2. On the CB in Privileged EXEC or global configuration mode, enter the **show spx-mon** command for information on PE state.

```
ICX7750-48F Router# show spx-mon
spx-mon is enabled

Total 2 PE(s) attached
Number of PEs in Ready State      : 2 (Id(s): 17, 23)
Number of PEs in Reserve          : 1 (Id(s): 18)
Number of PEs in Config-mismatch  : 0
Number of PEs in Image-Mismatch   : 0

CLI: sh spx-mon pe-join <cb-cport> can be used to diagnose pe-join issues

Active CPU Utilization
1   sec avg 1 percent busy
5   sec avg 1 percent busy
60  sec avg 1 percent busy
300 sec avg 1 percent busy

PE CPU Utilization:           Normal
Spx Interface Utilization:    Very low
Spx Interface Errors:         None
PE User Port Errors:         None
```

```
-----
                                SPX CB [CASC PORT]
CHAINS
CB Port   Epoch |Ring   Id     FSM State|Remote CB port | Chain
-----
2/1/1     9     NO     0     INIT    INVALID    PE17--PE23
```

The example shows that spx-mon is enabled, two PEs (17 and 23) are attached and in Ready state, and one PE configuration is reserved (PE 18). There are no configuration issues, and CPU Utilization is normal, while SPX usage is very low and error-free. One PE chain is connected through CB port 2/1/1.

3. For information on a PE unit joining the domain, enter the **show spx-mon pe-join** command followed by the port number for the CB cascade port.

```
ICX7750-26Q(config)# show spx-mon pe-join 2/1/1
Error! Last PE 23 in the chain has no DOWNSTREAM SPX ports in UP state
Above error(s) needs to be corrected...
```

The example checks CB SPX port 2/1/1 and shows a PE join issue for PE unit 23.

In this situation, CB SPX port 2/1/1 is connected to a PE chain with PE 23 as the last PE. A new PE cannot join the chain until at least one of the SPX ports on PE 23 is up. The system has detected that no SPX port is up to allow the new PE to join.

## System Validation of Network Changes

The system validates numerous items after any of the following events:

- A PE joins the Campus Fabric domain.
- A PE ages out of the Campus Fabric domain.
- An SPX LAG is updated.

- An SPX port changes state.
- The CB active controller switches over or fails over to the standby controller.

When any of these changes occur, the following items are checked to confirm that the change has been completed successfully for all involved network components.

- SPX ports are shown as being in the correct state on the CB and the PE.
- SPX port hardware configuration is correct.
- SPX topology database is correct.
- SPX LAGs are correct.
- PE virtual ports have been created correctly.
- PE forwarding entries are correct.
- Appropriate PEs are in the Ready state.
- On the standby controller, relevant information has been validated.

## Sample show spx-mon Output Indicating Issues

The following example shows two PEs are in Ready state with no errors. There is reserved configuration for another PE. Assuming that the user has attached only two PEs, no corrections are necessary.

However, if the user expected three PEs to be attached and in Ready state, some diagnosis is required. The output includes potential CLI guidance that indicates the **show spx-mon pe-join** command can be used for the appropriate CB port (through which the inactive unit is attached) to diagnose the issue.

```
ICX7750-48F Router# show spx-mon
spx-mon is enabled

Total 2 PE(s) attached
Number of PEs in Ready State      : 2 (Id(s): 17, 23)
Number of PEs in Reserve          : 1 (Id(s): 18) <--- Reserved configuration for 1 PE
Number of PEs in Config-mismatch  : 0
Number of PEs in Image-Mismatch   : 0

CLI: sh spx-mon pe-join <cb-cport> can be used to diagnose pe-join issues <--- CLI help for additional
diagnosis

Active CPU Utilization
 1 sec avg 1 percent busy
 5 sec avg 1 percent busy
60 sec avg 1 percent busy
300 sec avg 1 percent busy

PE CPU Utilization:      Normal
Spx Interface Utilization: Very low
Spx Interface Errors:    None
PE User Port Errors:     None
```

## Monitoring Traffic for an SPX Port

Command output for the **show spx-mon** command includes information on SPX interface utilization and gives an overview of CB-PE and PE-PE traffic. The following example shows that PE SPX port 17/2/1 is using 18% of its traffic capacity in both directions.

```
ICX7750-48F Router# show spx-mon
spx-mon is enabled

Total 2 PE(s) attached
Number of PEs in Ready State      : 2 (Id(s): 17, 23)
Number of PEs in Reserve          : 1 (Id(s): 18)
Number of PEs in Config-mismatch  : 0
Number of PEs in Image-Mismatch   : 0

CLI: sh spx-mon pe-join <cb-cport> can be used to diagnose pe-join issues

Active CPU Utilization
1   sec avg 1 percent busy
5   sec avg 1 percent busy
60  sec avg 1 percent busy
300 sec avg 1 percent busy

PE CPU Utilization:          Normal
PE 17:
Rx utilization Port 17/2/1   18%
Tx utilization Port 17/2/1   18%

Spx Interface Errors:       None
PE User Port Errors:       None
```

## CB Active Controller with SPX LAG Issues

The following example indicates that SPX LAG port 2/1/1 has an incorrect PE database index. Command output displays the warning "Port 2/1/1 doesn't have matching PE db."

```
ICX7750-48F Router# show spx-mon
spx-mon is enabled

Total 2 PE(s) attached
Number of PEs in Ready State      : 2 (Id(s): 17, 23)
Number of PEs in Reserve          : 1 (Id(s): 18)
Number of PEs in Config-mismatch  : 0
Number of PEs in Image-Mismatch   : 0

CLI: sh spx-mon pe-join <cb-cport> can be used to diagnose pe-join issues

Active CPU Utilization
1   sec avg 1 percent busy
5   sec avg 1 percent busy
60  sec avg 7 percent busy
300 sec avg 3 percent busy

Port 2/1/1 doesn't have matching PE db
CLI sh spx debug lag all can be used for more information <--- Error condition indicated for Port 2/1/1
                                                                <--- CLI help for additional diagnosis

PE CPU Utilization:          Normal
Spx Interface Utilization:   Very low
Spx Interface Errors:       None
PE User Port Errors:       None
ICX7750-48F Router#
```

The CLI help indicates that the **show spx debug lag all** command can be used for additional diagnosis. As shown in the example, debug command output provides the SPX LAG ID (columns 1 and 4), lists the ports in each SPX LAG (column 1), provides a database index number (column 2), and displays a port type for each port in the LAG (column 3). In the example, the database index for ports 1/1/1 and 2/1/1 do not match although they should.

```
ICX7750-48F Router# show spx debug lag all

spx-lag ID 3072

Port          PortExtDb Index      Port type      lag_id
1/1/1         0                    1              3072  |<-- Database mismatch
2/1/1         f                    1              3072  |   on 1/1/1 and 2/1/1

spx-lag ID 3073

Port          PortExtDb Index      Port type      lag_id
1/1/6         6                    1              3073

spx-lag ID 3074

Port          PortExtDb Index      Port type      lag_id
1/1/2         ff                   1              3074
1/1/3         ff                   1              3074
```

Using the keyword **distributed** derives SPX LAG information directly from remote PEs. The following example displays information on SPX LAGs derived directly from PE unit 19.

```
ICX7750-48F Router# show spx debug lag all dist units 19

*****
Response from PE 19:
*****

spx-lag ID 1
Port          ECID      Port type      lag_id
19/1/1       236      5              1
19/1/2       236      5              1

spx-lag ID 2
Port          ECID      Port type      lag_id
19/2/1       235      2              2
```

## Standby Controller with High CPU Utilization

The following example shows high CPU utilization on the standby controller.

```
ICX7750-48F Router# show spx-mon
spx-mon is enabled

Total 2 PE(s) attached
Number of PEs in Ready State      : 2 (Id(s): 17, 23)
Number of PEs in Reserve          : 1 (Id(s): 18)
Number of PEs in Config-mismatch  : 0
Number of PEs in Image-Mismatch   : 0

CLI: sh spx-mon pe-join <cb-cport> can be used to dignose pe-join issues

Active CPU Utilization
1   sec avg 1 percent busy
5   sec avg 1 percent busy
60  sec avg 1 percent busy
300 sec avg 1 percent busy

Standby CPU Utilization          <--- All measured intervals show high CPU use on the standby controller.
1   sec avg 99 percent busy
5   sec avg 99 percent busy
60  sec avg 255 percent busy
300 sec avg 255 percent busy

PE CPU Utilization:              Normal
Spx Interface Utilization:       Very low
Spx Interface Errors:            None
PE User Port Errors:             None
```

## Standby Controller with Topology Mismatch Issues

The following example shows an inconsistency in the Campus Fabric domain topology stored on the standby controller.

```
ICX7750-48F Router# show spx-mon
spx-mon is enabled

Total 2 PE(s) attached
Number of PEs in Ready State      : 2 (Id(s): 17, 23)
Number of PEs in Reserve          : 1 (Id(s): 18)
Number of PEs in Config-mismatch  : 0
Number of PEs in Image-Mismatch   : 0

CLI: sh spx-mon pe-join <cb-cport> can be used to diagnose pe-join issues

Active CPU Utilization
1   sec avg 1 percent busy
5   sec avg 1 percent busy
60  sec avg 1 percent busy
300 sec avg 1 percent busy

Port 2/1/1 doesn't have matching PE db
CLI sh spx debug lag all can be used for more information
PE 17: Standby Topology and PE db don't match, sh spx debug lag all can used to get details <--- Standby
                                         topology
                                         mismatch

Standby CPU Utilization
1   sec avg 99 percent busy
5   sec avg 99 percent busy
60  sec avg 255 percent busy
300 sec avg 255 percent busy

PE CPU Utilization:              Normal
Spx Interface Utilization:       Very low
Spx Interface Errors:            None
PE User Port Errors:             None
```

### PE Join Issue: No Available SPX Port

The **show spx** command output in the following example indicates that unit 2 is the CB active controller for the Campus Fabric domain. The active controller has only one SPX port, port 2/1/1. Any PE must join through that port. The topology shows a chain of two PE units (PE 17 and PE 23). Any new PE must join after PE 23.

The configuration shows reserve PE configuration for PE 18. If the PE had been expected to join, the **show spx-mon** command set can be used for troubleshooting.

```
ICX7750-48F Router# show spx
T=26m14.9: alone: standalone, D: dynamic cfg, S: static
ID  Type      Role      Mac Address  Pri State  Comment
1   S ICX7750-48XGF standby  cc4e.2438.a580 128 remote Ready
2   S ICX7750-48XGF active   cc4e.2438.8d80 128 local  Ready
17  S ICX7450-24G  spx-pe   cc4e.246c.e2b8 N/A remote Ready
18  S ICX7450-48G  spx-pe   0000.0000.0000 N/A reserve
23  S ICX7450-48G  spx-pe   cc4e.246c.ea50 N/A remote Ready

      standby      active
      +----+      +----+
2/4| 1 |2/1--2/1| 2 |
      +----+      +----+
          +-----+      +-----+
2/1/1--2/2| 17 |2/3--2/3| 23 |
          +-----+      +-----+
```

The **show spx-mon pe-join** output for CB SPX port 2/1/1 indicates that the connected PE chain does not have an SPX port from the last PE in the chain (PE 23) that a new PE unit could join.

```
ICX7750-48F Router# show spx-mon pe-join 2/1/1
Error! Last PE 23 in the chain has no DOWNSTREAM SPX ports
Above error(s) needs to be corrected...
```

### PE Join Issue: No SPX Port in the Up State

The following example shows CB unit 2 as the active controller for the Campus Fabric domain. PE unit 18 has reserve configuration and has not joined the Campus Fabric domain. The problem can be diagnosed with the **show spx-mon** or the **show spx-mon pe-join** command.

```
ICX7750-48F Router# show spx
T=13m4.7: alone: standalone, D: dynamic cfg, S: static
ID  Type      Role      Mac Address  Pri State  Comment
1   S ICX7750-48XGF standby  cc4e.2438.a580 128 remote Ready
2   S ICX7750-48XGF active   cc4e.2438.8d80 128 local  Ready
17  S ICX7450-24G  spx-pe   cc4e.246c.e2b8 N/A remote Ready
18  S ICX7450-48G  spx-pe   0000.0000.0000 N/A reserve
23  S ICX7450-48G  spx-pe   cc4e.246c.ea50 N/A remote Ready

      standby      active
      +----+      +----+
2/4| 1 |2/1--2/1| 2 |
      +----+      +----+
          +-----+      +-----+
2/1/1--2/2| 17 |2/3--2/3| 23 |2/1-
          +-----+      +-----+
```

In this case, the **show spx-mon pe-join** command is executed on CB port 2/1/1, and the output indicates that the last PE in the chain has no active downstream SPX port.

```
ICX7750-48F Router# show spx-mon pe-join 2/1/1
Error! Last PE 23 in the chain has no DOWNSTREAM SPX ports in UP state
Above error(s) needs to be corrected...
```

When the **show interface brief** command is executed for the problem port (23/2/1), output confirms that the link is down. Once the link is restored, an SPX connection can be created or restored with PE unit 18.

```
ICX7750-48F Router# show interface brief ethernet 23/2/1

Port      Link    State Dupl Speed Trunk Tag Pvid Pri MAC          Name
23/2/1    Down   None  None None  None No  1   0   cc4e.246c.ea81
```

### PE Join Issue: PE Ring with ACL Issues

The **show spx-mon** command can be used to diagnose issues related to ACLs used to create SPX rings.

```
ICX7750-48F Router# show spx-mon
spx-mon is enabled

Total 2 PE(s) attached
Number of PEs in Ready State      : 2 (Id(s): 17, 23)
Number of PEs in Reserve          : 1 (Id(s): 18)
Number of PEs in Config-mismatch  : 0
Number of PEs in Image-Mismatch   : 0

CLI: sh spx-mon pe-join <cb-cport> can be used to diagnose pe-join issues

Active CPU Utilization
1   sec avg 1 percent busy
5   sec avg 1 percent busy
60  sec avg 7 percent busy
300 sec avg 3 percent busy

Port 17/2/2 has incorrect acl config <--- ACL issues indicated on port.

PE CPU Utilization:          Normal
Spx Interface Utilization:   Very low
Spx Interface Errors:       None
PE User Port Errors:        None
ICX7750-48F Router#
```

In the example, PE port 17/2/2 is an SPX uplink port with an incorrect ACL configuration.



## Sample show spx-mon history Output

The following output for the **show spx-mon history** command provides sample ECP (IEEE Edge Control Protocol) packet flow between CB and PE units. The keyword **distributed** indicates that the history information is derived directly from one or more designated PE units (in this case, from PE unit 19). Without the keyword, the history is derived from the CB.

```
ICX7750-48F Router# show spx-mon history distributed 19

*****
Response from PE 19:
*****
51m17.8933 Unit 19 ecp_process_pdu: RxAck port_id 19/2/1, ecid 235, rxSeq 11, fSeq = 12, txSeq 12, fAck 0,
ack 0, lSeq 11
    [stack: 002d1360 00a1a0cc 00f0eee0 00f0fcd8 00c309f8 010a34e0 00615180 010a]
51m17.8786 Unit 19 ecp_process_pdu: RxAck port_id 19/2/1, ecid 235, rxSeq 10, fSeq = 11, txSeq 11, fAck 2,
ack 2, lSeq 11
    [stack: 002d1360 00a1a0cc 00f0eee0 00f0fcd8 00c309f8 010a34e0 00615180 010a]
51m17.8724 Unit 19 ecp_process_pdu: TxAck port_id 19/2/1, ecid 235, rxSeq 11, fSeq = 10, txSeq 11, fAck 1,
ack 2, lSeq 11
    [stack: 002d201c 00a1a0cc 00f0eee0 00f0fcd8 00c309f8 010a34e0 00615180 010a]
51m17.8667 Unit 19 ecp_transmit: port_id 19/2/1, ptype 1002, ecid 235, fSeq = 10, txSeq 11, fAck 1, ack 2,
lSeq 11
    [stack: 002cd7e4 002f2bfc 002f53cc 002f6704 002ffa34 003008f8 002f7b2c 002f]
51m17.8393 Unit 19 ecp_process_pdu: RxPkt port_id 19/2/1, cc4e.2438.8e00, ecid 235, rxSeq 11, fSeq = 10,
txSeq 10, fAck 1, ack 1, lSeq 10
    [stack: 002d18ec 00a1a0cc 00f0eee0 00f0fcd8 00c309f8 010a34e0 00615180 010a]
51m17.8212 Unit 19 ecp_process_pdu: RxAck port_id 19/2/1, ecid 235, rxSeq 9, fSeq = 10, txSeq 10, fAck 1,
ack 1, lSeq 10
    [stack: 002d1360 00a1a0cc 00f0eee0 00f0fcd8 00c309f8 010a34e0 00615180 010a]
51m17.8148 Unit 19 ecp_process_pdu: TxAck port_id 19/2/1, ecid 235, rxSeq 10, fSeq = 9, txSeq 10, fAck 0,
ack 1, lSeq 10
    [stack: 002d201c 00a1a0cc 00f0eee0 00f0fcd8 00c309f8 010a34e0 00615180 010a]
51m17.8065 Unit 19 ecp_transmit: port_id 19/2/1, ptype 1002, ecid 235, fSeq = 9, txSeq 10, fAck 0, ack 1,
lSeq 10
    [stack: 002cd7e4 002f2bfc 002f53cc 002f6704 002ffa34 003008f8 002f7b2c 002f]
51m17.7532 Unit 19 ecp_process_pdu: RxPkt port_id 19/2/1, cc4e.2438.8e00, ecid 235, rxSeq 10, fSeq = 9,
txSeq 9, fAck 0, ack 0, lSeq 9
    [stack: 002d18ec 00a1a0cc 00f0eee0 00f0fcd8 00c309f8 010a34e0 00615180 010a]
51m17.6644 Unit 19 ecp_process_pdu: TxAck port_id 19/2/1, ecid 235, rxSeq 9, fSeq = 9, txSeq 9, fAck 0, ack
0, lSeq 9
    [stack: 002d201c 00a1a0cc 00f0eee0 00f0fcd8 00c309f8 010a34e0 00615180 010a]
51m17.6571 Unit 19 ecp_transmit: port_id 19/2/1, ptype 1002, ecid 235, fSeq = 9, txSeq 9, fAck 0, ack 0,
lSeq 9
    [stack: 002cd7e4 002f2bfc 002f53cc 002f6704 002ffa34 003008f8 002f7b2c 002f]
51m17.6021 Unit 19 ecp_process_pdu: RxPkt port_id 19/2/1, cc4e.2438.8e00, ecid 235, rxSeq 9, fSeq = 9,
txSeq 9, fAck 0, ack 0, lSeq 8
    [stack: 002d18ec 00a1a0cc 00f0eee0 00f0fcd8 00c309f8 010a34e0 00615180 010a]
48m53.2531 Unit 19 ecp_process_pdu: RxAck port_id 19/2/1, ecid 235, rxSeq 8, fSeq = 9, txSeq 9, fAck 0, ack
0, lSeq 8
    [stack: 002d1360 00a1a0cc 00f0eee0 00f0fcd8 00c309f8 010a34e0 00615180 010a]
48m53.1509 Unit 19 ecp_process_pdu: TxAck port_id 19/2/1, ecid 235, rxSeq 8, fSeq = 8, txSeq 8, fAck 0, ack
0, lSeq 8
    [stack: 002d201c 00a1a0cc 00f0eee0 00f0fcd8 00c309f8 010a34e0 00615180 010a]
48m53.1438 Unit 19 ecp_transmit: port_id 19/2/1, ptype 1002, ecid 235, fSeq = 8, txSeq 8, fAck 0, ack 0,
lSeq 8
    [stack: 002cd7e4 002f2bfc 002f53cc 002f6704 002ffa34 003008f8 002f7b2c 002f]
48m53.0729 Unit 19 ecp_process_pdu: RxPkt port_id 19/2/1, cc4e.2438.8e00, ecid 235, rxSeq 8, fSeq = 8,
txSeq 8, fAck 0, ack 0, lSeq 7
    [stack: 002d18ec 00a1a0cc 00f0eee0 00f0fcd8 00c309f8 010a34e0 00615180 010a]
48m48.9443 Unit 19 ecp_process_pdu: RxAck port_id 19/2/1, ecid 235, rxSeq 7, fSeq = 8, txSeq 8, fAck 0, ack
0, lSeq 7
    [stack: 002d1360 00a1a0cc 00f0eee0 00f0fcd8 00c309f8 010a34e0 00615180 010a]
48m48.6568 Unit 19 ecp_process_pdu: TxAck port_id 19/2/1, ecid 235, rxSeq 7, fSeq = 7, txSeq 7, fAck 0, ack
0, lSeq 7
    [stack: 002d201c 00a1a0cc 00f0eee0 00f0fcd8 00c309f8 010a34e0 00615180 010a]
48m48.6499 Unit 19 ecp_transmit: port_id 19/2/1, ptype 1002, ecid 235, fSeq = 7, txSeq 7, fAck 0, ack 0,
lSeq 7
    [stack: 002cd7e4 002f2bfc 002f53cc 002f6704 002ffa34 003008f8 002f7b2c 002f]
```

```

48m47.4032 Unit 19 ecp_process_pdu: RxPkt port_id 19/2/1, cc4e.2438.8e00, ecid 235, rxSeq 7, fSeq = 7,
txSeq 7, fAck 0, ack 0, lSeq 6
  [stack: 002d18ec 00a1a0cc 00f0eee0 00f0fcd8 00c309f8 010a34e0 00615180 010a]
48m47.0706 Unit 19 ecp_process_pdu: RxAck port_id 19/2/1, ecid 235, rxSeq 6, fSeq = 7, txSeq 7, fAck 0, ack
0, lSeq 6
  [stack: 002d1360 00a1a0cc 00f0eee0 00f0fcd8 00c309f8 010a34e0 00615180 010a]
48m47.0431 Unit 19 ecp_process_pdu: TxAck port_id 19/2/1, ecid 235, rxSeq 6, fSeq = 6, txSeq 6, fAck 0, ack
0, lSeq 6
  [stack: 002d201c 00a1a0cc 00f0eee0 00f0fcd8 00c309f8 010a34e0 00615180 010a]
48m47.0358 Unit 19 ecp_transmit: port_id 19/2/1, ptype 1002, ecid 235, fSeq = 6, txSeq 6, fAck 0, ack 0,
lSeq 6
  [stack: 002cd7e4 002f2bfc 002f53cc 002f6704 002ffa34 003008f8 002f7b2c 002f]
48m47.0283 Unit 19 ecp_process_pdu: RxPkt port_id 19/2/1, cc4e.2438.8e00, ecid 235, rxSeq 6, fSeq = 6,
txSeq 6, fAck 0, ack 0, lSeq 5
  [stack: 002d18ec 00a1a0cc 00f0eee0 00f0fcd8 00c309f8 010a34e0 00615180 010a]
48m18.2364 Unit 19 PE joined
  
```

## The SPX Monitoring PE Join Checklist

The following checklist can be used to diagnose PE-join issues in conjunction with SPX monitoring tools.

**TABLE 15** The SPX Monitoring PE Join Checklist

Problem	Items to Check	Related Commands and Instructions
PE unit is not responding or does not join CB — No transit PE in topology	The CB port is up.	<b>show interfaces brief</b>
	The CB is enabled.	<b>show spx</b> (spx cb-enable is present)
	The SPX port or LAG is correct.	<b>show spx debug lag all</b> The command as shown derives information on LAG connections and members from the CB. Use the keyword <b>distributed</b> to derive information directly from remote PE units. For example, <b>show spx debug lag all distributed all-pe</b>
	The LLDP packet is being received by the CB.	<b>show spx pe topology level</b>
	Topology is valid.	<b>show spx</b>
	Free PE IDs are available.	<b>show spx</b>
PE does not join — Transit PE present in topology	PEs on the path joined and are in Ready state.	<b>show spx-mon</b>
	PE forwarding entries match upstream and cascade port configuration.	<b>show spx-mon</b>
	CB port is up.	<b>show interfaces brief</b>
	LLDP packet is being received.	<b>show spx pe topology level</b>
	Topology is valid.	<b>show spx</b>
	Free PE IDs are available.	<b>show spx</b>
PE joins but does not achieve Ready state, or PE ages out	CB port is up.	<b>show interfaces brief</b>
	The port has no errors or unidirectional failures.	<b>show statistics</b>
	CSP port state is correct.	<b>show spx debug port unit/slot/port</b>

## Troubleshooting PE Data Ports

Traffic loss can occur on data ports attached to Campus Fabric PE units for several reasons. You can send an ECID port ping to help isolate the cause of traffic loss.

Once you issue the **spx ping** command, the CB sets up an ECID trap for the ECID associated with the PE data port under test and places the port in loopback mode. When the PE confirms the loopback, the CB sends a single ECID ping, identifiable by its sequence number, to the port under test. In

a successful test, the PE port receives the ECID ping directed to it and loops it back to the CB. The CB then removes the loopback. In an unsuccessful test, the PE port does not respond to the ping within a maximum of four seconds, and the PE removes the loopback after a four-second timer expires.

If an ECID port ping succeeds but data traffic issues persist, the cause is likely related to an application issue, such as incorrect IP settings. If the ECID port ping fails, the cause of traffic loss on the port is likely related to an SPX infrastructure issue.

Consider the following before performing an ECID port ping:

- ECID pings place the port under test in loopback and, as a result, can disrupt control and data traffic on the port.
- ECID pings do not work for ports that are physically down.
- ECID pings are not supported for SPX ports.
- ECID pings can be initiated only from the CB.
- Each ECID ping is sent to a specific PE, and only one ping can be sent at a time.

Perform the following steps to send an ECID ping to a PE data port.

1. In Privileged EXEC mode, enter the **spx ping** command followed by the port number to be tested. When prompted, enter **y** to continue.

```
ICX7750-48F Router# spx ping 17/1/1
SPX Ping Port is disruptive to control, data traffic. Are you sure, you want to continue (enter 'y'
or 'n'): y
```

```
ICX7750-48F Router# Received response (seq# 6) for ecid1 ping to 17/1/1 port from PE 17
```

The example shows a successful test on PE port 17/1/1. Traffic loss on the port may be due to a problem with IP settings or other applications issues.

```
ICX7750-48F Router# spx ping 17/1/2
SPX Ping Port is disruptive to data traffic. Are you sure, you want to continue (enter 'y' or 'n'): y
```

```
ICX7750-48F Router# No ecid ping response for spx port 17/1/2, seq 8 from PE 17 !
```

The example shows a failed test on PE port 17/1/2. The port cannot be reached, possibly due to an SPX infrastructure issue.

2. (Optional) When an ECID port ping fails, enter the **show spx csp events distributed** command for the PE under test to verify that the loopback command from the CB was received.

```
ICX7750-48F Router# show spx csp events distributed 17
*****
Response from PE 17:
*****
PE 0: port 17/1/1 loopback disable pass (13 minute(s) 58 second(s) )
[stack: 002dffdc 0030dd90 002f36b4 002eaae8 002ebc2c 002ea064 00324a3c 002c53dc 009f9740 00ee16c0
00ee24b4 00c0acc8]
...
<snip>
...
PE 0: port 17/1/1 loopback enable pass (13 minute(s) 58 second(s) )
[stack: 002dfdd0 0030dd90 002f36b4 002eaae8 002ebc2c 002ea064 00324a3c 002c53dc 009f9740 00ee16c0
00ee24b4 00c0acc8]
```

The example shows that PE port 17/1/1 received a loopback enable command from the CB and that the PE later disabled the loopback.

3. (Optional) Based on the outcome of the ECID port ping, follow any prescribed steps for troubleshooting packet loss.

# Campus Fabric General Troubleshooting Checklist

The following table lists some common problems and items you can check before contacting a technical support representative.

For information on stacking issues, refer to "Traditional Stack Troubleshooting" in the *RUCKUS FastIron Stacking Configuration Guide*. For information on technical support, refer to [Contacting RUCKUS Customer Services and Support](#) on page 9.

A PE unit may not join the Campus Fabric domain for many reasons. For other reasons, a PE may not achieve a Ready state, or the PE may age out after entering the Ready state. Check the applicable items listed in the following sections when a PE fails.

**TABLE 16** Campus Fabric General Troubleshooting Checklist

Problem	Items to Check	Related Commands and Instructions
1. PE unit is not responding or does not join CB.	a. Cable is correctly connected and connecting port is up.	On CB and PE port: <b>show interfaces brief</b>
	b. PE unit shows up and is in Ready state.	On CB and PE: <b>show running-config</b> On CB: <b>show spx</b>
	c. All transit PE units are correctly connected and are in Ready state.	On CB: <b>show spx</b>
	d. All transit PE units are correctly configured.	<b>show spx debug port unit/slot/port</b> (for all SPX LAG members)
	e. CB configuration is correct. SPX is enabled ( <b>spx cb-enable</b> is present in configuration).	On CB: <b>show running-config</b>
	f. There is an SPX port or SPX LAG connection from the CB to the PE unit.	On CB: <b>show running-config</b> On CB: <b>show spx</b> <b>show spx debug port unit/slot/port</b> (for all SPX LAG members)
	g. Is the PE unit stuck in sync?	Contact technical support.
2. Topology not supported.	Is the configuration blocked?	Review "Invalid Topology" message on console for details. If no message appears, check that maximum configuration limits for PEs or CBs have not been exceeded.
3. CB cannot assign PE ID.	Ports and connections are valid. PE ID is available (not already in use or reserved).	The following message in the CB port log indicates the pe-id is reserved, but the topology of the joining PE does not match the reserved configuration:  "No available ID: must remove unused "pe-id."  In this case, you should remove the unused pe-id configuration.
4. Image mismatch.	Is there a major image mismatch?	<b>show stack</b> <b>show spx</b>
	Path to FTP server is configured correctly. The image folder is present. FTP server is connected.	<b>show running-config</b>  Ping the server address to verify connectivity.
	Auto image copy is disabled.	From CB: <b>show stack detail</b>  If auto image copy should be disabled, manually download the image from the CB to the PE unit, or reset the PE unit.

**TABLE 16** Campus Fabric General Troubleshooting Checklist (continued)

Problem	Items to Check	Related Commands and Instructions
5. Configuration mismatch.	PE configuration on CB matches actual PE modules.	If the PE configuration on the CB does not match actual PE modules, remove the reserved configuration on the CB. Issue a <b>no spx unit ID</b> command to remove the reserved configuration of the PE unit ID. This causes the CB to relearn the correct modules for the PE unit. If the <b>no spx unit xx</b> command is blocked due to the configuration on the PE unit, remove the erroneous configuration.
6. A connected PE unit detaches from the CB.	SPX LAG or SPX port status.	If ports are down, investigate reasons. If ports are up, a further issue is indicated. Collect <b>supportsave spx</b> output for both CB and PE for further analysis. Call technical support for assistance.
7. SPX LAG issues are evident.	LAG configuration is correct.  Connections on both sides of the LAG match. Speeds on both sides match.  Ports in LAG are operational.  Topology is valid.	<b>show spx debug lag all</b> Adding the <b>distributed</b> keyword to the command. Without the keyword, the command output is derived from the CB. The following example displays information on LAG members and connections directly from PE units.  <b>show spx debug lag all distributed all-pe</b>
8. LAG issues between PE ports are evident.	LAG configuration is correct.	<b>show lag</b>
9. Multicast traffic not being forwarded to one or more virtual ports.	Virtual ports are part of mcache OIF.	Run the <b>show ip pim vrf vrf1 mc</b> command on both the router and the joined PE locally and compare output.
	Issues persist.	Contact technical support for any additional assistance.

