Table of Contents

E70 Audio Systems

Subject	Page
Introduction	3
Audio Systems in the New BMW X5	3
System Overview	4
E70 Audio Systems	4
System Components	18
Professional Radio (CHAMP)	19
Amplifiers and Speakers	22
HiFi System	23
Top-HiFi System	24
Top-HiFi Amplifier	25
IKT Antennas	26
Blocking Circuit and HBL Filter	28
Roof Antenna	30
Radio Antennas	31
FM Antenna Diversity	32
Digital Tuners	33
CD Changer	35
Retrofitting a CD Changer	38
Audio Jack	38
Service Information	39
Diagnosis	39
Reset	40
Service Concept	40
HiFi Amplifier	40
Top-HiFi Amplifier	41
Antenna Diagnosis	41
Service Mode	41
Hissing or Interference on Radio	42
CD Changer	43

Audio Systems

Model: E70

Production: From Start of Production

OBJECTIVES

After completion of this module you will be able to:

- Identify the Audio Systems Used on the E70.
- Describe the different functions of the two Audio Systems of the E70
- Identify the components integrated to the Audio Systems on the E70.

Introduction

Audio Systems in the New BMW X5

The following audio equipment is available in the new BMW X5 (E70):

- Professional radio
- Professional navigation system.

The Professional radio is standard equipment. The standard equipment comprises the iDrive with controller and Central Information Display (CID). US vehicles are equipped with CHAMP (Central Head unit and Multimedia Platform), the new platform for the mid-range radio segment in BMW vehicles.

An enhancement of the CCC (Car Communication Computer) is available as the Head unit for the Professional navigation system.

The Professional radio and Professional navigation system offer eight favorites buttons. There are six favorites buttons that can be assigned favorites while the other two are assigned fixed functions.

CHAMP Favorites Buttons



The radio and navigation system can be combined with the following speaker and amplifier systems:

- HiFi system
- Top-HiFi system.

The Professional radio with HiFi system is standard equipment on US vehicles.

The Top-HiFi system is available as option "Professional HiFi system".

Digital radio is available in addition to AM and FM stations, the SDARS satellite tuner will be available from market launch. High definition radio will be available at a later date.

Note: A single-slot CD changer is available in a BMW for the first time. This changer holds six discs, which are inserted into the unit without the use of a magazine.

System Overview

E70 Audio Systems

The HiFi system has five tweeters, five mid-range speakers and two central bass speakers. The HiFi amplifier has a K-CAN connection for diagnostics and coding.

The Top-HiFi system has seven tweeters, seven mid-range speakers and two central bass speakers. The Top-HiFi amplifier is connected to the MOST.

The following pages show the input/output diagrams and system circuit diagrams for the audio systems of the E70:

- Amplifier and speaker systems
- Digital tuners.

The input/output diagram shows the subscribing control units, sensors, controls and components. For emphasis, only the control unit concerned is shown in its block representation. The input/ output diagram gives an overview of the system concerned, represented as a signal path. It does not show whether the signals are sent via bus connections, additional control units, by fixed wire or by wireless. This detailed information is contained in the system circuit diagram

The input/output diagram also applies to the HiFi system, if the HiFi amplifier were shown in place of the Top-HiFi amplifier.

The wheel speed signals are sent from the DSC control unit on the PT-CAN and converted to the K-CAN protocol in the Junction-box ECU (JB). The instrument cluster processes the speed signal and outputs this on the K-CAN.

The differences between the HiFi system and the Top-HiFi system are illustrated in the following system circuit diagrams.

HiFi System and Top-HiFi System Input/output Diagram

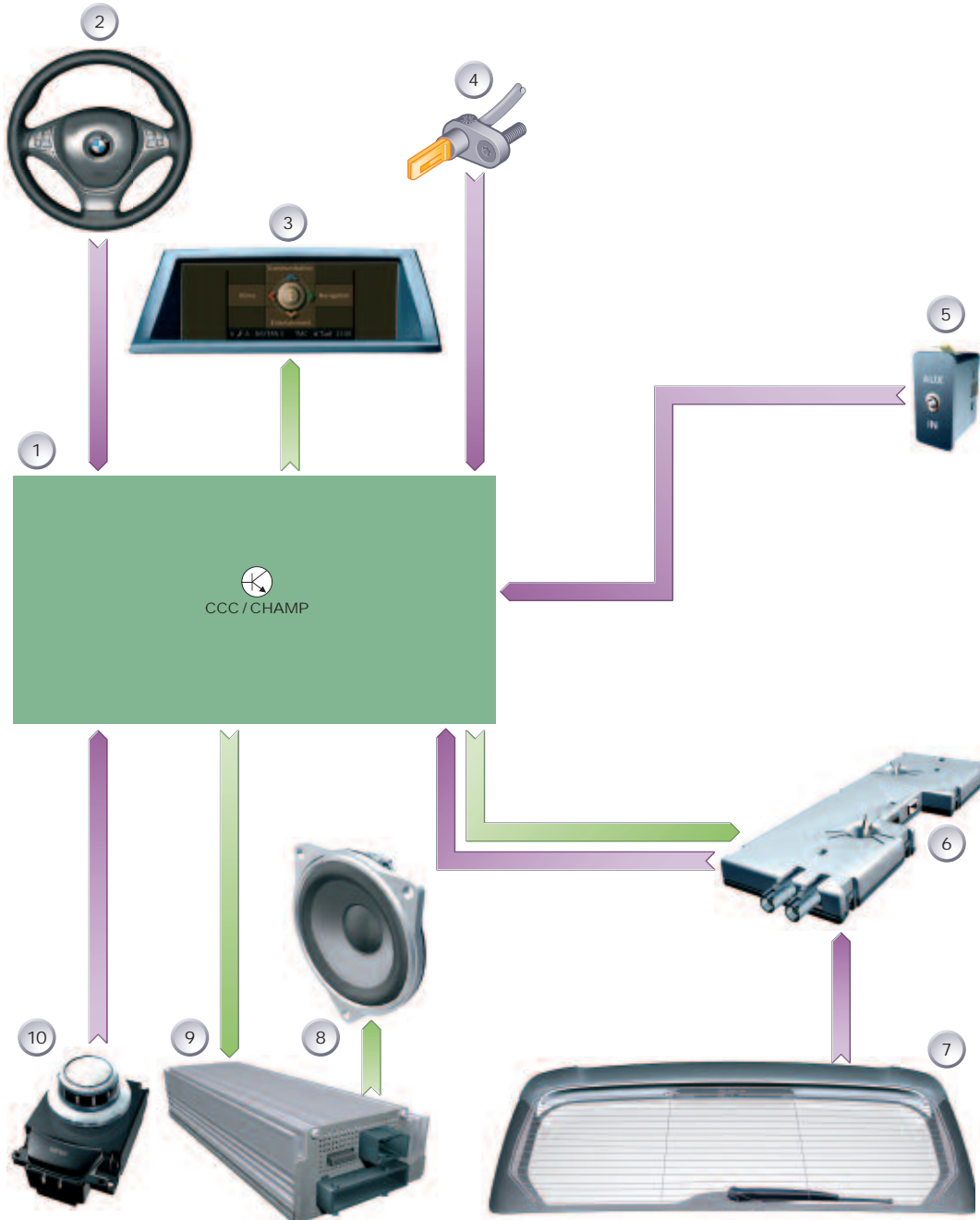

Index	Explanation	Index	Explanation
1	Head unit (CCC or CHAMP)	6	Antenna amplifier with diversity module
2	Multifunction steering wheel (MFL)	7	Rear spoiler (FM1, AM) and rear window antennas (FM2, FM3)
3	Central information display (CID)	8	Audio speaker
4	Wheel speed sensor	9	Top-HiFi amplifier
5	Audio jack	10	Controller

HiFi System Circuit Diagram

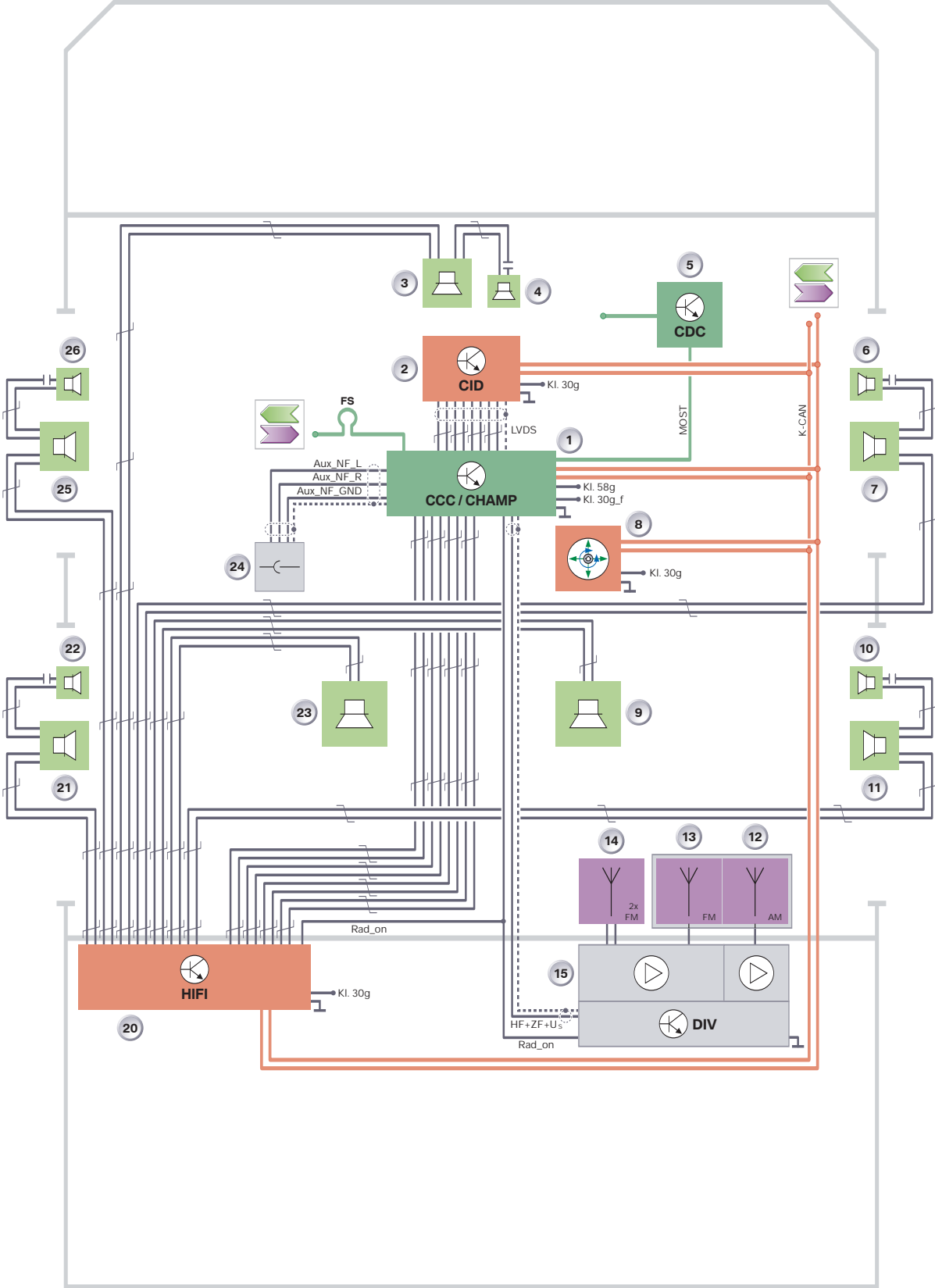

Legend for HiFi System Circuit Diagram

Index	Explanation	Index	Explanation
1	Head unit	12	Rear spoiler antenna (AM)
2	Central information display	13	Rear spoiler antenna (FM1)
3	Mid-range speaker, front center	14	Rear window antennas (FM2, FM3)
4	Tweeter, front center	15	Antenna amplifier with diversity module
5	CD changer	20	HiFi amplifier
6	Tweeter, front right door	21	Mid-range speaker, rear left door
7	Mid-range speaker, front right door	22	Tweeter, rear left door
8	Controller	23	Central bass speaker, left
9	Central bass speaker, right	24	Audio jack
10	Tweeter, rear right door	25	Mid-range speaker, front left door
11	Mid-range speaker, rear right door	26	Tweeter, front left door
LVDS	Low voltage differential signal	MOST	Media Oriented System Transport (digital bus)
Aux_NF	Audio input for additional audio sources	FS	MOST direct access
Rad_On	Control signal or power supply	US	Switching voltage
HF	High frequency signal	ZF	Intermediate frequency signal

K-CAN signals at the CCC/CHAMP control unit

In/out	Signal	Source/sink	Function
In	Speed signal	> Wheel speed sensor r > DSC -JB - Kombi	Speed-dependent volume control
In	Button stroke	> Steering wheel buttons > SZL	Volume, station selection
In	Terminal status	> START/STOP button > CAS	Switch-on conditions
In (CCC only)	Terminal 58g	> Photo diode > FRM	Lighting

MOST signals at the CCC/CHAMP control unit

In/out	Signal	Source/sink	Function
In	Decoded audio signals	> CD > CD changer	Audio playback
In	Control signals	>CD changer	ID3 tags, CD content
In/out	Control signals	>CD changer	CD selection, track selection,terminal control

The HiFi amplifier is connected to the K-CAN for coding and diagnostics. There is no facility provided for programming the HiFi amplifier.

The HiFi amplifier is woken by the Rad_On signal sent by fixed wire from the Head unit.

The tweeters and mid-range speakers are connected in parallel. The capacitors at the tweeters act as duplexers and, in the case of the HiFi system, are electrolytic.

The CHAMP receives the terminal 58g (lighting) signal by fixed wire. The CCC receives it via the K-CAN.

NOTES

PAGE

Top-HiFi System Circuit Diagram

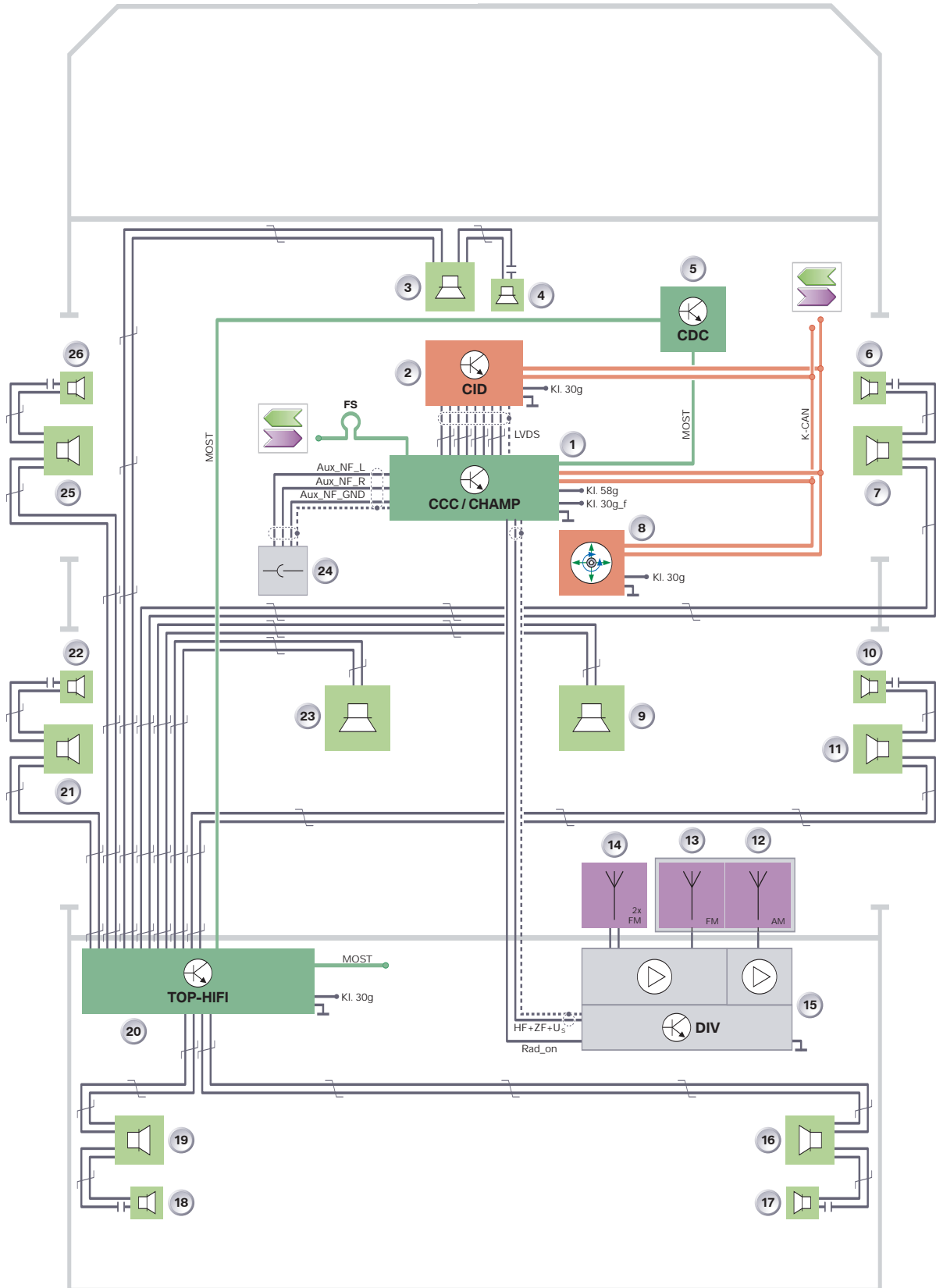

Legend for Top HiFi System Circuit Diagram

Index	Explanation	Index	Explanation
1	Head unit	14	Rear window antennas (FM2, FM3)
2	Central information display	15	Antenna amplifier with diversity module
3	Mid-range speaker, front center	16	Mid-range speaker, D-pillar right
4	Tweeter, front center	17	Tweeter, D-pillar right
5	CD changer	18	Tweeter, D-pillar left
6	Tweeter, front right door	19	Mid-range speaker, D-pillar left
7	Mid-range speaker, front right door	20	Top-HiFi amplifier
8	Controller	21	Mid-range speaker, rear left door
9	Central bass speaker, right	22	Tweeter, rear left door
10	Tweeter, rear right door	23	Central bass speaker, left
11	Mid-range speaker, rear right door	24	Audio jack
12	Rear spoiler antenna (AM)	25	Mid-range speaker, front left door
13	Rear spoiler antenna (FM1)	26	Tweeter, front left door
LVDS	Low voltage differential signal	MOST	Media Oriented System Transport (digital bus)
Aux_NF	Audio input for additional audio sources	FS	MOST direct access
Rad_On	Control signal or power supply	US	Switching voltage
HF	High frequency signal	ZF	Intermediate frequency signal

K-CAN signals at the CCC/CHAMP control unit

In/out	Signal	Source/sink	Function
In	Speed signal	> Wheel speed sensor r > DSC -JB - Kombi	Speed-dependent volume control
In	Button stroke	> Steering wheel buttons > SZL	Volume, station selection
In	Terminal status	> START/STOP button > CAS	Switch-on conditions
In (CCC only)	Terminal 58g	> Photo diode > FRM	Lighting

MOST signals at the CCC/CHAMP control unit

In/out	Signal	Source/sink	Function
In	Decoded audio signals	> CD > CD changer	Audio playback
In	Control signals	>CD changer	ID3 tags, CD content
In/out	Control signals	>CD changer	CD selection, track selection, terminal control
Out	Audio signals	> Top-HiFi > audio speakers	Audio signals
Out	Control signals	>Top-HiFi	Speed-dependent volume control and equalizer, terminal control
Out	Rad_On	>Top-HiFi	ON/OFF

The Top-HiFi amplifier is connected to the MOST for programming, coding and diagnostics. The tweeters and mid-range speakers are connected in parallel. The capacitors at the tweeters act as duplexers and, in the case of the Top-HiFi system, are high-quality foil capacitors. The M-ASK and CHAMP receive the terminal 58g (lighting) signal by fixed wire. The CCC receives it via the K-CAN.

Satellite Tuner (SDARS) Input/output Diagram

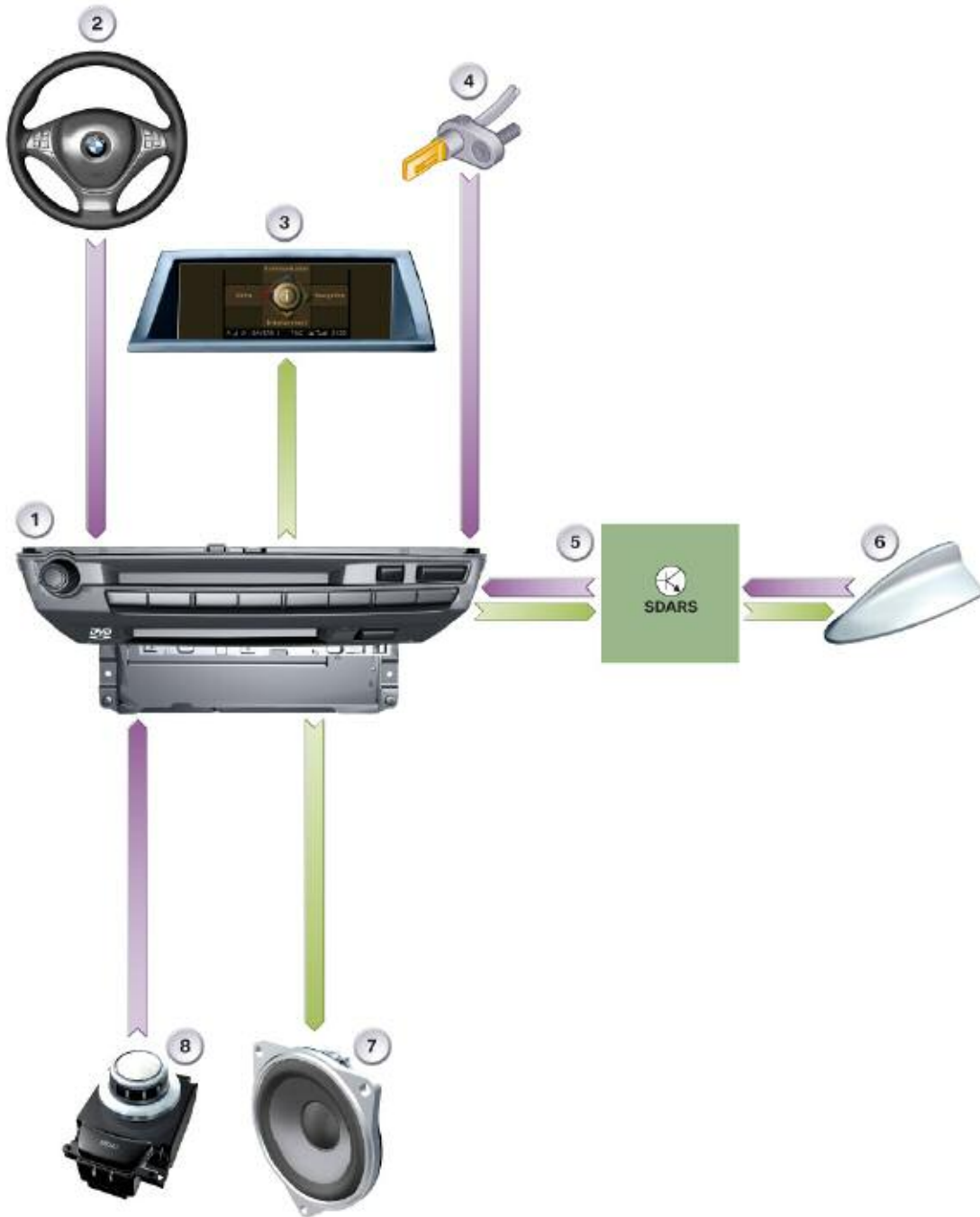

Index	Explanation	Index	Explanation
1	Head unit (CCC)	5	Satellite tuner (SDARS)
2	Multifunction steering wheel (MFL)	6	Roof antenna (SDARS)
3	Central information display (CID)	7	Audio speaker
4	Wheel speed sensor	8	Controller

The input/output diagram also applies to the CHAMP. The roof antenna receives SDARS signals transmitted by satellite. The signals are amplified by an amplifier integrated in the roof antenna and forwarded to the SDARS control unit. The antenna amplifier is supplied with power from the SDARS control unit.

The SDARS control unit decodes the digital audio signals and sends these to the Head unit on the MOST. The Head unit converts the audio data into analogue LF signals. The LF signals are output through the speakers.

Note: That SDARS is operated using the iDrive and information such as track title, artist or album title are output in the CID.

NOTES

PAGE

Satellite Tuner (SDARS) System Circuit Diagram

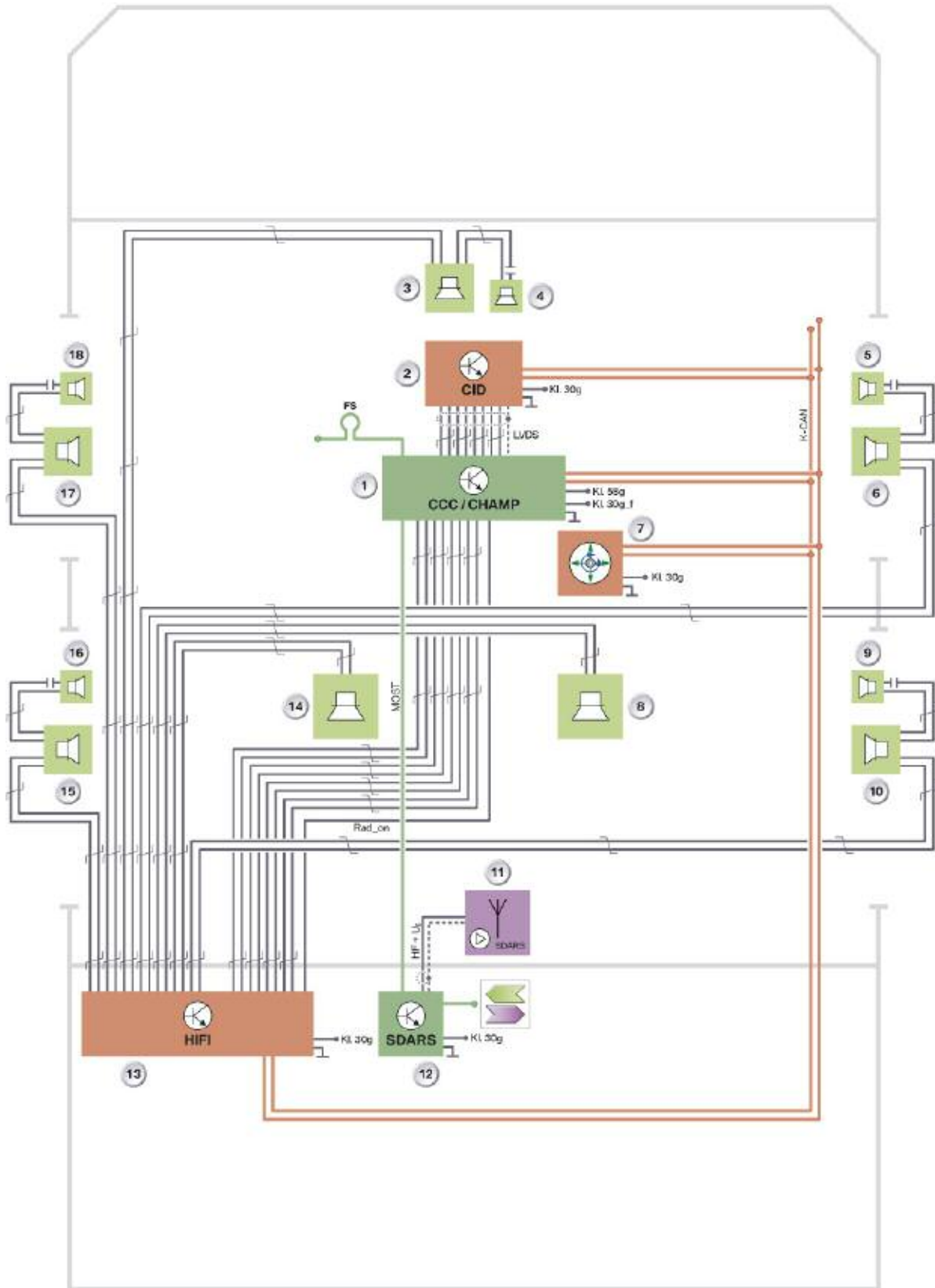

Legend for Satellite Tuner (SDARS) System Circuit Diagram

Index	Explanation	Index	Explanation
1	Head unit	10	Mid-range speaker, rear right door
2	Central information display	11	Roof antenna (SDARS)
3	Mid-range speaker, front center	12	SDARS control unit
4	Tweeter, front center	13	HiFi amplifier
5	Tweeter, front right door	14	Central bass speaker, left
6	Mid-range speaker, front right door	15	Mid-range speaker, rear left door
7	Controller	16	Tweeter, rear left door
8	Central bass speaker, right	17	Mid-range speaker, front left door
9	Tweeter, rear right door	18	Tweeter, front left door,
MOST	Media Oriented System Transport (digital bus)	FS	MOST direct access
LVDS	Low voltage differential signal	UB	Power supply
Rad_On	Control signal or power supply		

MOST signals at the SDARS control unit

In/Out	Signal	Source	Function
Out	Decoded audio signals	> Head unit	Audio playback
In/out	Control signals	> Head unit	Station selection, station identifier, terminal control

SDARS is also available in conjunction with the Top-HiFi system. CHAMP receives the terminal 58g (lighting) signal by fixed wire. The CCC receives it via the K-CAN.

System Components

This section describes the audio systems in the E70. It is divided into the following chapters:

- Head units
- Amplifiers and speakers
- Antennas
- Digital tuners
- Peripherals

The following Audio Systems are available for the E70:

- Professional radio
- Professional navigation system.

The US vehicles are equipped with the new head unit platform called CHAMP (Central Head unit and Multimedia Platform) The CCC (Car Communication Computer) is available as the head unit for the Professional navigation system. The head units offer eight favorites buttons.

The radio and navigation system with integrated audio function can be combined with the following speaker and amplifier systems:

- HiFi system
- Top-HiFi system.

Professional radio with HiFi system is standard equipment in the US vehicles. The Top-HiFi system is available as option. "SIRIUS Satellite Radio" (SDARS) is also available as option. The "high-definition radio" (HDC) will be available at a later date.

A single-slot 6 CD changer is available in a BMW for the first time. This changer holds six discs, which are inserted into the unit without the use of a magazine.

The CHAMP and CD changer support playback of MP3 and WMA files. The CCC supports playback of MP3 files.

Professional Radio (CHAMP)

The CHAMP has six assignable favorites buttons. Button 7 is assigned with FM/AM selection, button 8 is for toggling the operating mode.

CHAMP combines the following control units in the one housing:

- RDS double tuner
- Audio system controller
- Gateway between MOST and K-CAN
- Interface to the Central Information Display.

CHAMPsystem can be used to control:

- Communication
- Entertainment
- Navigation
- Air conditioning (climate control)
- Settings (5th menu).



Index	Explanation	Index	Explanation
1	favorites buttons	4	CD drive slot
2	Rotary knob	5	Rocker switch for station selection/CD track skip
3	CD drive eject button		

Professional Radio with NAV (CCC)



Index	Explanation	Index	Explanation
1	DVD drive slot	5	CD drive eject button
2	favorites buttons	6	Rocker switch for station selection/CD track skip
3	Rotary knob	7	DVD drive eject button
4	CD drive slot		

Note: Button 7 is assigned with FM/AM selection, button 8 is for toggling the operating mode

The CCC combines the following control units in one housing:

- Navigation computer/GPS module; map view and/or cursor view in the CID
- RDS double tuner
- Audio system controller (ASK)
- Gateway between MOST and K-CAN
- Interface to control display (LVDS).

Two drives are integrated in the housing:

- DVD player
- CD player

When the navigation system is not in use, its DVD drive can be used to play audio CDs. The playback of video files is not supported.

The CCC together with the controller and CID form the iDrive system. The system can be used to control:

- Communication
- Entertainment
- Navigation
- Air conditioning (climate control)
- Settings (5th menu).

The MP3 directory structure corresponds to that of the PC. There is no limit to the number of directories, subdirectories and music tracks that the CCC can support. However, the time taken for the drive to read the contents of the CD when the CD is inserted is longer, depending on how much data is stored on the CD.

Amplifiers and Speakers

The speaker systems in the E70 are, as in other Series, available in two quality levels:

- HiFi system
- Top-HiFi system.

The HiFi system achieves double the power of the standard stereo system. In addition, the HiFi system is equipped with a 7-channel amplifier with digital equalizer.

The optional Top-HiFi system achieves double the power of the standard HiFi system and uses a digital 9-channel amplifier. Optimum audio playback in the vehicle is achieved thanks to complex digital signal processing.

The HiFi system has twelve speakers while the Top- HiFi system has 16 speakers each with different auxiliary amplifiers.

The central bass speakers are located under the front seats. They are coupled to the side sills to increase the resonance volume necessary for bass reproduction.

The Professional radio and the Professional navigation system can be combined with any of the amplifier/speaker systems, provided the specific national variants are taken into consideration.

Note: The HiFi and Top-HiFi systems feature separate speakers for the treble and midrange frequencies.

Even though the diameters of the speakers in the HiFi and Top-HiFi systems are the same, there are differences in the power output of the speakers. This is achieved through the use of different materials in the diaphragms, coils and magnets. The terms Medium and High are used in the table below for distinction purposes.

	Stereo system	HiFi system	Top-HiFi system
Output	CHAMP/CCC: 2°40 W (2 Ω) bass/ broadband 4°25 W (4 Ω)	Auxiliary amplifier: 2°40 W (2 Ω) bass 5°25 W (4 Ω)	Auxiliary amplifier: 2°125 W (8 Ω) bass 7°50 W (4 Ω)
Sound intensity	>98 dB as from 63 Hz	>104 dB as from 50 Hz	>110 dB as from 40 Hz
Bandwidth	40 Hz up to 15 kHz	30 Hz up to 20 kHz	20 Hz up to 20 kHz
Linearity	±4.5 dB	±3 dB	±1.5 dB
Tweeter Manufacturer		26 mm (Medium) Phillips	26 mm (High) Phillips
Broadband speaker Manufacturer	100 mm Phillips		
Mid-range speaker Manufacturer		100 mm (Medium) Phillips	100 mm (High) Phillips
Woofer Manufacturer	Phillips 160 mm	Phillips 217 mm	Phillips 217 mm

HiFi System

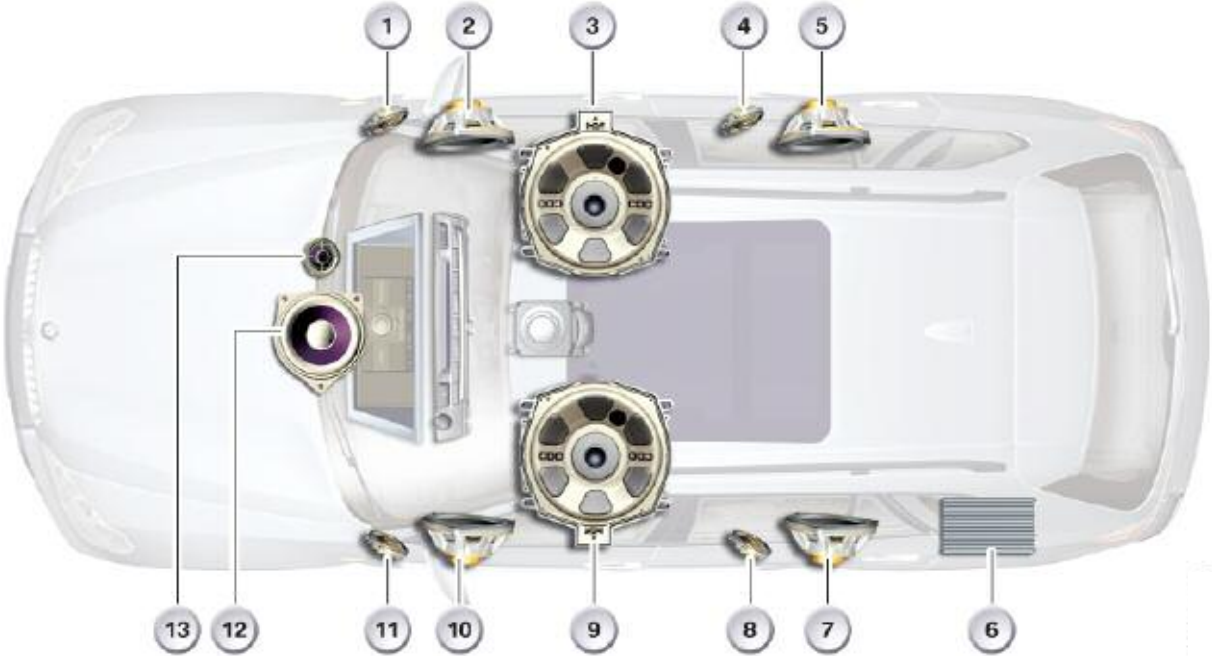

Index	Explanation	Index	Explanation
1	Tweeter, front right door	8	Tweeter ,rear left door
2	Mid-range speaker, front right door	9	Central bass speaker, left
3	Central bass speaker, right	10	Mid-range speaker, front left door
4	Tweeter, rear right door	11	Tweeter, front left door
5	Mid-range speaker ,rear right door	12	Mid-range speaker, front center
6	HiFi amplifier	13	Tweeter, front center
7	Mid-range speaker, rear left door		

Top-HiFi System

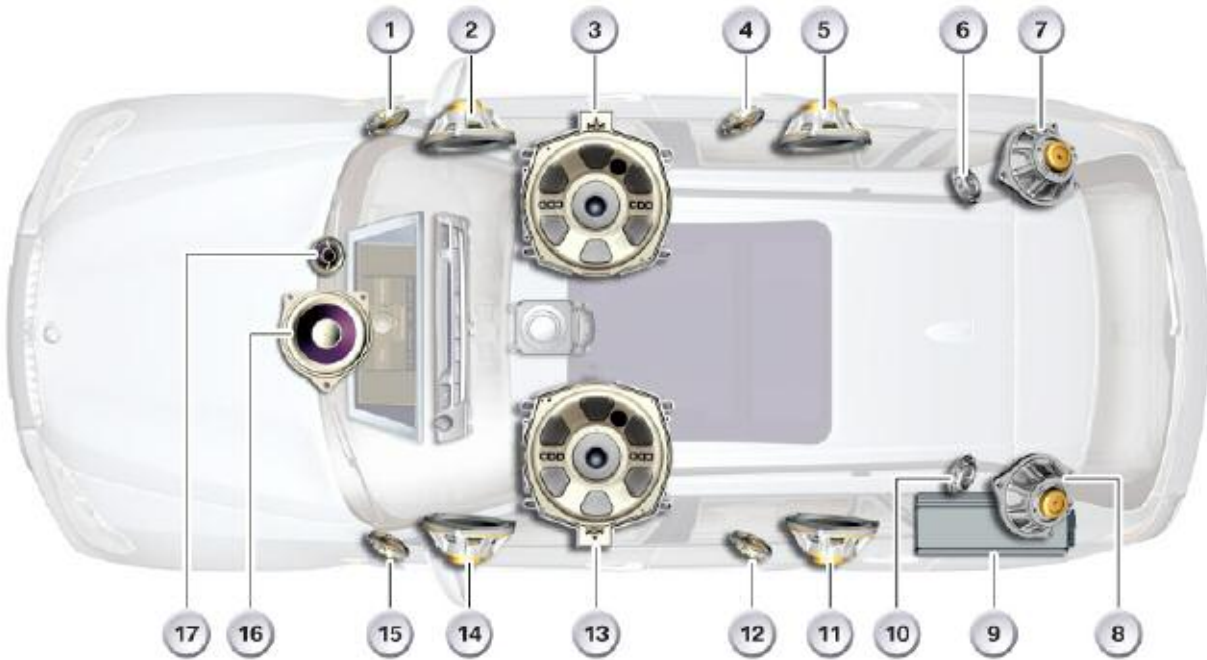

Index	Explanation	Index	Explanation
1	Tweeter ,front right door	10	Tweeter ,D-pillar left
2	Mid-range speaker, front right door,	11	Mid-range speaker,rear left door
3	Central bass speaker, right	12	Tweeter, rear left door
4	Tweeter, rear right door	13	Central bass speaker, left
5	Mid-range speaker, rear right door	14	Mid-range speaker, front left door
6	Tweeter,D-pillar right	15	Tweeter, front left door
7	Mid-range speaker, D-pillar right	16	Mid-range speaker, front center
8	Mid-range speaker ,D-pillar left	17	Tweeter, front center
9	Top-HiFi amplifier		

Top-HiFi Amplifier



Index	Explanation	Index	Explanation
1	Safety fuse	3	MOST
2	Power supply	4	Audio signals

The essential features of the Top-HiFi amplifier are:

- MOST control unit
- 7-channel equalizer with control by iDrive
- Higher output power in the low frequency range
- 15 V output voltage for each mid-range speaker/tweeter
- 30 V output voltage for each central bass speaker.

The audio signals and the control signals are sent in digital form to the Top-HiFi amplifier through the fiber-optic cable (MOST). Programming, coding and diagnostics are carried out via the MOST.

To generate surround sound information from a stereo signal, the Top-HiFi amplifier in the E70 supports Dolby Surround Pro Logic II.

This method replaces the Logic7 application from other BMW vehicles. This makes it possible to generate a spatial sound pattern from the stereo signal that is only delivered by the left and right channel.

The signals of the individual channels are output with time correction from the 16 available speakers of the Top-HiFi system in the E70. This achieves an homogenous sound pattern for the listener in the 7.2 format.

Audio playback can also be adjusted by the customer using the 7-channel equalizer integrated in the Top-HiFi amplifier. After signals have been processed, the audio signals are forwarded as analogue low frequency (LF) signals to the speakers.

The Top-HiFi amplifier supports speed dependent equalization in addition to speed dependent volume control. The effect is that the frequency response is adjusted in relation to the speed of the vehicle.

A total of 16 speakers are controlled through nine audio channels with Top-HiFi quality:

- one tweeter and mid-range speaker in each of the front doors
- one tweeter and mid-range speaker in the instrument panel
- one tweeter and mid-range speaker in each of the rear doors
- one tweeter and mid-range speaker in each of the D-pillars
- one central bass speaker under each of the front seats.

Note: The Top-HiFi amplifier is located in the rear left of the luggage compartment behind the side panel trim.

IKT Antennas

The E70 has up to five antennas systems, depending on equipment options:

- FM/AM radio (spoiler and rear window Antennas)
- Digital tuners (roof antenna and left side window)
- Navigation system (roof antenna)
- Telephone (roof antenna) additionally:
 - Bluetooth antenna under the center console for mobile phone connection
 - Emergency antenna, rear left (only in conjunction with Telematics Control Unit TCU)

IKT Antennas

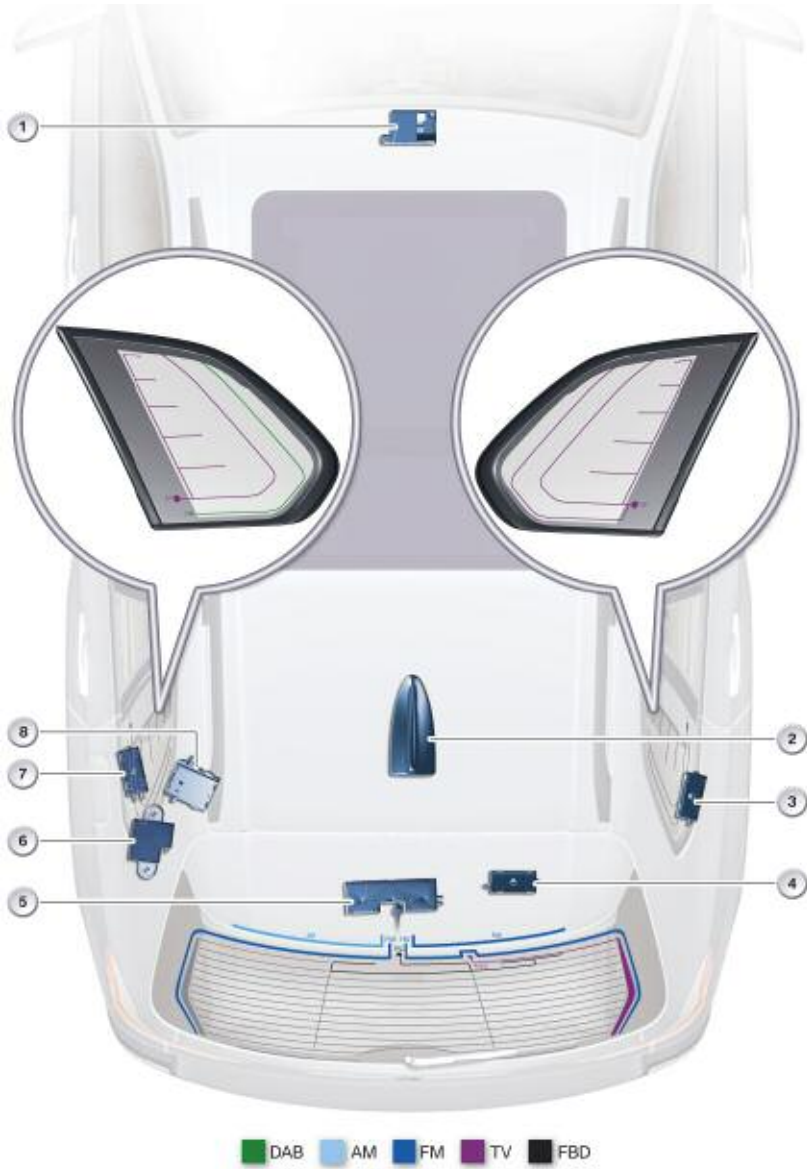

Index	Explanation	Index	Explanation
1	Bluetooth antenna	5	Antenna amplifier with diversity module
2	Roof antenna(navigation, telephone, digital tuners)	6	SOS antenna
3	TV2 amplifier (not for U.S.)	7	TV1/DAB band III amplifier (not for U.S.)
4	TV3 amplifier (not for U.S.)	8	Blocking circuit and HBL filter

In addition to the antennas listed above are the Antennas for the remote control (FBD) and the

nine Antennas for Comfort Access (four on the outside and five in the interior). You will find further information in the "Central locking", "Comfort Access" and "Car Access System" Product Information documentation.

The radio antennas for AM (waveband: LW, MW, KW) and FM (waveband: UHF) reception are described below.

The HBL filter is fitted to suppress interference pulses from the additional brake light during radio reception. The same unit houses the capacitor of the rear window heater blocking circuit. The inductive resistor for the blocking circuit is located in the supply line of the rear window heating.

Blocking Circuit and HBL Filter



Index	Explanation	Index	Explanation
1	Rear window heater, vehicle side Connector color code: black	4	Securing screw with ground connection
2	HBL filter, vehicle side Connector color code: black	5	HBL filter, rear window side Connector color code: purple
3	Rear window heater, rear window side Connector color code: white		

Rear Window Blocking Circuit Inductive Resistor



Index	Explanation	Index	Explanation
1	Inductive resistor	3	Connection, vehicle side Connector color code: black
2	Rear window connection		

Roof Antenna

- Mobile phone antenna
- Telematics Control Unit (TCU) telephone antenna
- GPS antennal
- SDARS satellite reception antenna.

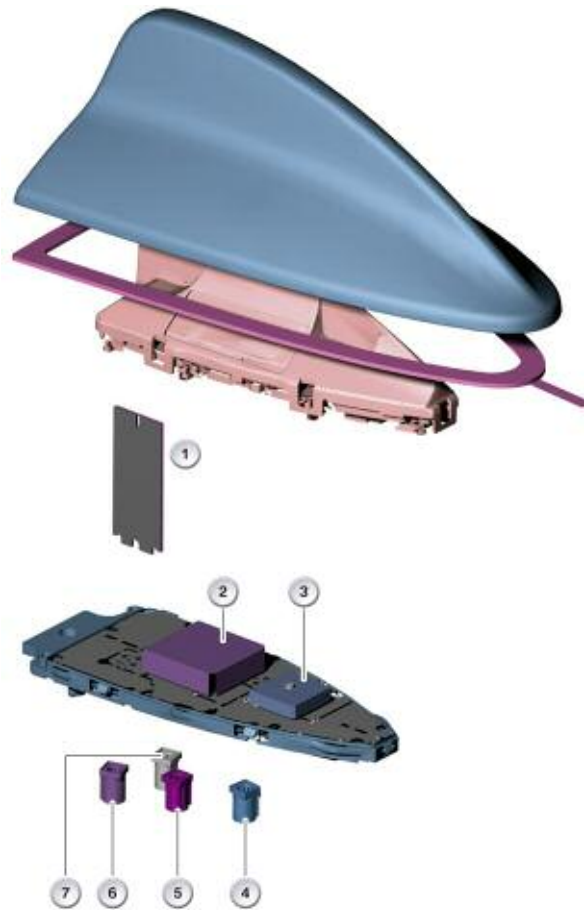

Index	Explanation	Index	Explanation
1	Telephone antennas for mobile phone and Telematics Control Unit (TCU)	5	SDARS signal, satellite and terrestrial Connector color code: pink
2	SDARS antenna for satellite reception	6	Telephone signal: connector color code: Bordeaux violet
3	GPS antenna	7	Telephone signal: connector color code: Grey
4	GPS signal connector color code: blue		

Note: The telephone antennas for the mobile phone and the TCU are on different sides of the same circuit board.

Radio Antennas

The high-frequency signals of the radio stations are received by the spoiler antenna (AM and FM1) and the rear window antenna (FM2 and FM3).

Antenna Amplifier with Diversity Module

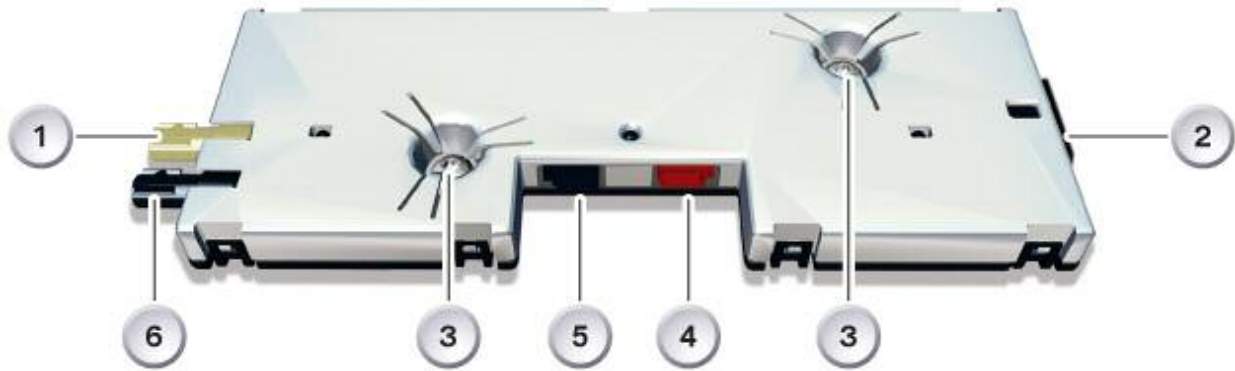

Index	Explanation	Index	Explanation
1	VICS signal (not for US)	4	Rear window antennas (FM2, FM3, TV3)
2	Power supply and FBD	5	Spoiler antennas (AM, FM1)
3	Securing screw with ground connection	6	AM/FM tuner signal Connector color code: black

The assignment of the antenna amplifier with diversity module may differ depending on the vehicle equipment. The TV3 signal is not currently used.

The antenna amplifiers for AM and FM are supplied with DC voltage from terminal Rad_On when the radio is switched on. The high-frequency signals of the AM, FM1 antenna in the spoiler and of the FM2, FM3 antennas on the rear window are sent to the antenna amplifier with diversity module by means of a ribbon cable.

Note: In US vehicles, the antenna amplifier also supports the frequencies of the weather band. Weather band is transmitted over seven channels in the frequency range from 162.400 MHz to 162.550 MHz.

Note: The antenna amplifiers are in the Diversity module. There are separate amplifiers for AM and FM. The installation location is on the inside of the tailgate above the rear window.

FM Antenna Diversity

In the E70, an FM antenna diversity is standard equipment.

The FM antenna diversity comprises:

- FM1, FM2 and FM3 antennas
- FM antenna amplifier with diversity module.

The sequence of the FM antenna diversity is defined as:

FM1 - FM2 - FM1 - FM3.

It then switches back to the FM1 antenna again.

The FM1 antenna has the best reception characteristics due to its location in the rear spoiler. The defined sequence in which the antennas are switched ensures that the FM antenna with the best reception characteristics has priority over the others.

For SW, MW and LW reception, no antenna diversity system is provided as there is only one AM antenna available.

The signal quality of the currently selected FM antenna (FM1 to FM3) is evaluated in the diversity module. The antenna diversity module will switch to the next FM antenna if the signal quality of the current radio station on the active antenna deteriorates to a certain level in terms of quality and field strength.

The switching takes place such manner that no interruption can be detected. The high-frequency signal from the active FM antenna at any particular time is fed by the antenna amplifier and Diversity module via a co-axial cable to the tuner in the radio or navigation system. The signal is then de-modulate in the tuner and output in the form of an audio signal through the speakers.

The radio or navigation system detects that a diversity module is installed and generates the changeover voltage U_s and the signal of the intermediate frequency (ZF) necessary for diversity operation. The ZF signal is analyzed by the electronic circuitry in the diversity module and is a copy of the currently selected radio station transmission on a fixed frequency of 10.7 MHz.

The switch between AM reception, FM diversity operation and diagnostics mode occurs in response to changeover voltage U_s .

This is generated by the radio and analyzed in the diversity module. Diversity operation is active when $U_s = 2.5$ V. AM mode is active, or the FM1 antenna is selected, when $U_s = 0$ V. Diagnostics mode is active when $U_s = 5$ V.

In total, up to three signals are therefore applied on the coaxial cable simultaneously.

- HF signal (e.g. 87.5 - 108 MHz) from the diversity module to the radio
- Control DC voltage U_s from the radio to the diversity module
- Intermediate frequency ($f_{ZF} = 10.7$ MHz) from the radio to the diversity module as the basis for evaluating the quality of the HF signal.

Note: Mutual influencing is not possible due to the different frequencies.

Digital Tuners

SDARS (Satellite Digital Audio Radio Service)



Index	Explanation	Index	Explanation
1	Power supply	3	SDARS signal Connector color code: pink
2	MOST		

SDARS enables you to receive digital radio signals and therefore enhances AM and FM reception. Digital transmissions are superior in quality to analogue transmissions. The satellite radio stations can be selected using the additional "SAT" menu item in the iDrive.

Advantages of digital satellite radio:

- Reception of same radio station across the entire US mainland (excluding Alaska)
- Digital reception of music, news and talk stations
- Wide choice of available music
- No commercial breaks
- Digital signal transmission provides greater immunity to external interference.

The SDARS system developed by Sirius Satellite Radio is supported. This uses three satellites which follow an elliptical orbit around the Earth. Because of the arrangement of the orbits, there are always two satellites over the reception area. In areas without coverage, the SDARS signals are beamed terrestrially. Both SDARS signals (satellite and terrestrial) are received by an antenna patch in the roof antenna and made available to the SDARS control unit. To make use of the signal, the feature must be enabled by the service provider Sirius.

Note: The separate satellite tuner is necessary because the signals are transmitted in the gigahertz band (microwave band). The satellite tuner is located in the luggage compartment on the left-hand side.

CD Changer

The new 6-disc CD changer (CDC) is available for the E70 the first time that a single-slot CD changer has been fitted in a BMW vehicle. It is manufactured by Alpine. The CD changer is integrated on the MOST network.



Index	Explanation	Index	Explanation
1	Buttons for operating trays	5	CD drive eject button
2	Load button for CD drive	6	MOST
3	Status display	7	Power supply
4	CD drive slot		

Single-slot CD Changer Shutter
(Front view without trim panel)

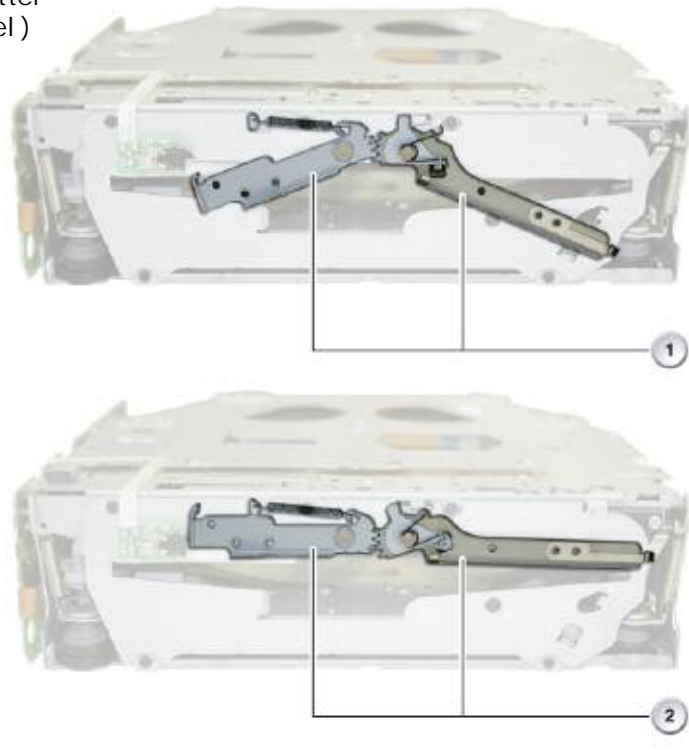

Index	Explanation	Index	Explanation
1	Shutter closed	2	Shutter open

Single-slot CD changer means that the CDs are loaded individually into the device without a magazine. A CD can be loaded by pressing the load button, followed by the button for the operating tray of the CD to be inserted. If no button is pressed after the load button has been tapped, the LED in the operating tray button assigned to the first free tray flashes. In the meantime, the tray moves into position.

When the tray is in the correct position, the status display begins to flash and the CD can be loaded. The contents of the CD are read as soon as the CD is inserted. The next CD cannot be inserted until the contents of this CD have been read. The rapid loading feature must be activated to be able to insert all CDs immediately one after the other. To do this, the load button must be pressed for approximately 2 seconds. The LEDs in the operating buttons assigned to free trays begin to flash. Up to 6 CDs can be inserted one after the other, depending on the number of trays free. The contents of the CDs inserted are read either once the final free tray has been filled, on expiry of a time out or if the load or eject button is pressed. An individual CD can be ejected by pressing the eject button followed by the operating button concerned. Pressing and holding the eject button ejects all the CDs.

The CDs cannot be loaded unless the shutter is open. The status display flashes when it is possible to insert a disc. Operation is described in detail in the Owner's Handbook for the vehicle.

Single-slot CD Changer Installation Location



The CD changer supports the following compressed file formats:

- MPEG-1 Layer 3 Audio (MP3) with ID3 tag version 1 and version 2
- Windows Media Audio (WMA) with WMA tags
- Advanced Audio Coding (AAC).

These files are decoded in the CD changer. The CD changer is accessible when the glove compartment is open. The following graphic shows how the CD changer is connected to the cross-member.

The data on the CD is decoded by the CD changer and converted into the digital MOST format.

If the vehicle is equipped with the stereo or HiFi speaker system, the digital data on the CD is sent to the head unit via the MOST. Here they are converted to analogue data and output via the amplifier and the speakers.

If the Top-HiFi system is installed, the decoded audio data is sent directly to the Top- HiFi amplifier via the MOST from where it is output. This direct transmission bypassing the head unit is made possible because data conversion and sound adjustment take place exclusively in the Top-HiFi amplifier.

Retrofitting a CD Changer

The fiber optics conductors for connecting the CD changer are arranged at the fiber optics connector in the luggage compartment such that they are not incorporated in the MOST ring. After retrofitting a CD changer, the fiber optics conductors for the CD changer preparation are unplugged at the fiber optics connector and connected to the MOST ring. It is then necessary to code the entire vehicle.

Audio Jack

The audio jack is used to connect an external audio source such as MP3, cassette or CD playback devices. The audio jack (Aux In) is standard equipment in the E70. It is located below the center armrest. A 12-V socket outlet is located in the immediate vicinity of the audio jack.

Service Information

Diagnosis

It is possible to run diagnostics on the HiFi amplifier thanks to its connection to the K-CAN. The following measures have been implemented to minimize interference during AM and also FM reception:

- Tailgate hinges with integrated ground straps
- Low-noise AM and FM antenna amplifiers
- ground connection on both silencers
- Shielded Wave barrier.

An audio test CD is available from the EPC that can be used to test drives.

The BMW diagnostic system contains the control unit entries listed in the table:

CHAMP Professional radio	CCC Professional navigation system
CHAMP-GW	CCC-GW
CHAMP-BO	CCC-BO
	CCC-A
	CCC-ANT
	CCC-ASK

Key for the table above:

Index	Explanation	Index	Explanation
GW	Gateway	A	Applications
BO	User interface	ANT	Antenna tuner
NAV	Navigation system	ASK	Audio system controller

Reset

All head units can be reset by following the procedure described below:

- Switch system ON/OFF
- BMW diagnostic system
- Disconnect from vehicle electrical system.

There is no specific button or button stroke combination on the CHAMP for performing a reset.

The CCC can be reset by simultaneously pressing and holding the eject buttons on the DVD and CD player and the rotary push button for approximately 10 seconds. The CID becomes blank. The CCC is then restarted.

Note: The MOST gateway (CHAMP, CCC) is muted for 2 seconds when a MOST control unit is reset.

Service Concept

The CHAMP is replaced as complete units.

The service concept of the CCC permits replacement of individual assemblies.

The following assemblies can be replaced:

- Fan
- CD and DVD player
- Front panel
- HIP
- Yaw rate sensor.

Note: Observe the ESD guidelines in case of replacement. The CCC must not be stood on its rear panel as the sockets may be damaged by the weight of the unit.

In diagnostics, the following diagnostic queries can be issued for the amplifiers available:

HiFi Amplifier

- Responds to diagnostics thanks to K-CAN connection
- Separate control of individual audio channels

Top-HiFi Amplifier

- Output of sinus tones by means of an internal sine-wave generator (configurable parameters: frequency, volume, speaker channel)
- Separate control of individual audio channels

Antenna Diagnosis

Antenna diagnostics on the E70 proceeds in the same way as diagnostics on the BMW 3 Series (E90, E91, E92), BMW 5 Series (E60, E61) and BMW 6 Series (E63, E64):

The self-diagnosis procedure for the diversity module is initiated in the diagnosis module of the BMW diagnosis system. The self-diagnosis comprises a check of the antenna inputs based on a DC measurement.

If the check proves positive, each individual FM antenna is switched on one after the other in a specified sequence and the signal quality evaluated (antenna scan). The AM reception can be evaluated in the LW, SW and MW range with the AM amplifier switched on and off. The diagnosis system evaluates the measurements and deduces the status when the self-diagnosis of the diversity module provides a positive result.

This procedure can also be carried out manually by switching the CHAMP into service mode:

The signal quality and field strength of the station currently tuned in can be displayed in service mode.

■ Service Mode

Service Mode is Accessed as Follows:

- Open Start menu
- Press and hold the controller for at least 10 seconds
- Move the controller 3 stops to the right
- Move the controller 3 stops to the left
- Move the controller 1 stop to the right
- Move the controller 1 stop to the left
- Move the controller 1 stop to the right
- Press the controller once.

Note: To exit Service mode press the Menu button.

Note: Low values with regard to signal quality and field strength may indicate to damaged antennas or the absence of terminal Rad_On.

Terminal Rad_On supplies power to the antenna amplifier and the diversity module.

■ Hissing or Interference on Radio

Check the following in the event of hissing or interference with radio reception:

- Station tuning
- Mechanical damage to the antenna structure
- Power supply terminal Rad_On for the antenna amplifiers in the diversity module.
- Antenna connector at diversity module
- Diversity module connected to ground by securing screws
- Antenna connector on radio or navigation system.

The following measures have been taken in the E70 to minimize reception interference of AM and FM stations:

- Tailgate connected to ground by the tailgate hinges with integrated ground straps
- Low-noise AM and FM antenna amplifiers with direct ground connection
- Ground connection on the left and right silencer
- Shielded Wave barrier.

The ground connection on the two silencers helps to suppress interference transmitted from the engine compartment (ignition electronics) along the exhaust system.

The exhaust system is a wave guide and, if no ground straps are used, it carries high-frequency interference to the rear end of the vehicle. At the end of the exhaust system, the interference is radiated out and couples into the antenna structures located at the rear of the vehicle. The ground straps on the silencers connect the interference to ground, thereby suppressing the interference. These ground connections have already been fitted to the BMW X5 (E53).

The shielded wave barrier connects to ground the screen of the coaxial line between the head unit and antenna diversity on the D-pillar. Interference transmitted by the screen is therefore conducted away to ground.



CD Changer

If the eject button is no longer working, a CD can be ejected using the diagnostic tester. If the CD is mechanically jammed in the drive, it is necessary to send in the CD changer.

When the MOST bus enters sleep mode, the contents of the CD that has been inserted and read is stored inside the head unit. There is therefore no need for this data to be read once more when the MOST boots up again. The data is not saved in the event of a low voltage situation before the MOST has entered sleep mode or a voltage interruption with the MOST active. For this reason, the contents of the inserted CDs have to be read once more when the MOST boots up.