Table of Contents

E70 Information and Communication Technology (IKT)

Subject	Page
Introduction	3
Information and Communication Technology (IKT)	3
Navigation Systems	3
Voice Activation Systems	4
Telephone Systems	4
Telecommunication Services	5
Bus System Overview	6
Components	10
IKT Component Locations	10
TCU with "Professional" Radio System Circuit Diagram	15
TCU with "Professional" Radio and Navigation Circuit Diagram	16
Signals and Functions	18

Information and Communication Technology

Model: E70

Production: From Start of Production

OBJECTIVES

After completion of this module you will be able to:

- Describe the Information and Communication System (IKT) used on the E70.
- Identify the components that make up the Information and Communication System (IKT).

Introduction

Information and Communication Technology (IKT)

IKT comprises systems that inform or entertain the driver and other occupants.

Depending on equipment configuration, the IKT also serves the purpose of making available servicing-relevant data and sending messages in the case of emergency.

This Product Information provides an overview of the IKT topics. The components available at the time of the market launch are described with the help of the vehicle outline diagram and the bus overview.

With the E70, a fiber optics-based bus is also used for data transmission in information and communication applications IKT in the BMW X5.

The MOST (Media Oriented System Transport) is already known from the following BMW vehicles:

- BMW 7 Series (E65, E66)
- BMW 6 Series (E63, E64)
- BMW 5 Series (E60, E61)
- BMW 3 Series (E90, E91, E92)

Navigation Systems

Map navigation (Professional navigation system) based on the Car Communication Computer (CCC) is provided in the E70. The functions correspond with the areas already known in the E60, E61, E63, E64, E90, E91 and E92.

Via the voice input, the CCC supports the entry of whole words for a country, town and street. It is still also possible to spell the destination.

For the market launch of the E70 in the USA, the (RTTI) traffic warning system (Real Time Traffic Information) is provided. The service is controlled by the "Traffic information for navigation" option and is currently included in the range of functions of the "Professional navigation system" option.

RTTI is transferred in the form of a data stream from particular FM stations. The data is received from the CCC FM tuner, evaluated and made available for the navigation system. In the navigation map, traffic issues are indicated by symbols. The traffic issues are also available in a list. The list entries are then sorted by the current distance between the vehicle and the traffic issue. If the traffic issue is on the current route, there is a voice output.

Voice Activation Systems

The High and Basic voice activation systems already familiar in the E60, E61, E63, E64, E90, E91 and E92 are available. The High voice activation system is used in the CCC.

The Basic voice activation system allows operation of the telephone functions and is used in the Telematics Control Unit (TCU).

Telephone Systems

The following telephone systems will be available:

- "Complete mobile phone station" option.
- "Carphone station" option.

"Telephone station" option comprises:

- Wiring harness to connect the Telematics Control Unit TCU, base plate, Bluetooth antenna, SOS antenna, SOS speaker, microphone and emergency call button with emergency call indicator lamp.
- Roof aerial with telephone aerial.

Telecommunication Services

The following well-known services from BMW ASSIST are available:

- Emergency call
 - Manually using the emergency call button
 - Automatically by airbag triggering
- Roadside assistance
 - Manually via the BMW ASSIST menu
- Service request
 - Manually via the BMW ASSIST menu
- BMW customer relations
 - Manually via the BMW ASSIST menu
- Auto request
 - Automatic service request, triggered by the instrument cluster when CBS warning messages appear
 - Activated in the BMW ASSIST menu
- Stolen Vehicle Recovery
 - Remote service, triggered on behalf of the customer by the ATX service provider.

Note: All services named here are available without restriction for all equipment specifications.

With the start of series production of the E70, the following new services are also planned:

- Remote Door Unlock
 - Unlocking of the vehicle, triggered on behalf of the customer by the ATX service provider.
- Concierge service
 - Download of points of interest, such as filling stations, restaurants, hotels, etc.
 - The service is started by the customer in the BMW ASSIST menu.

Note: Both services require the "Complete mobile phone station USA" option to be fitted. If the navigation system is fitted, the concierge service data can be accepted for destinations.

Bus System Overview

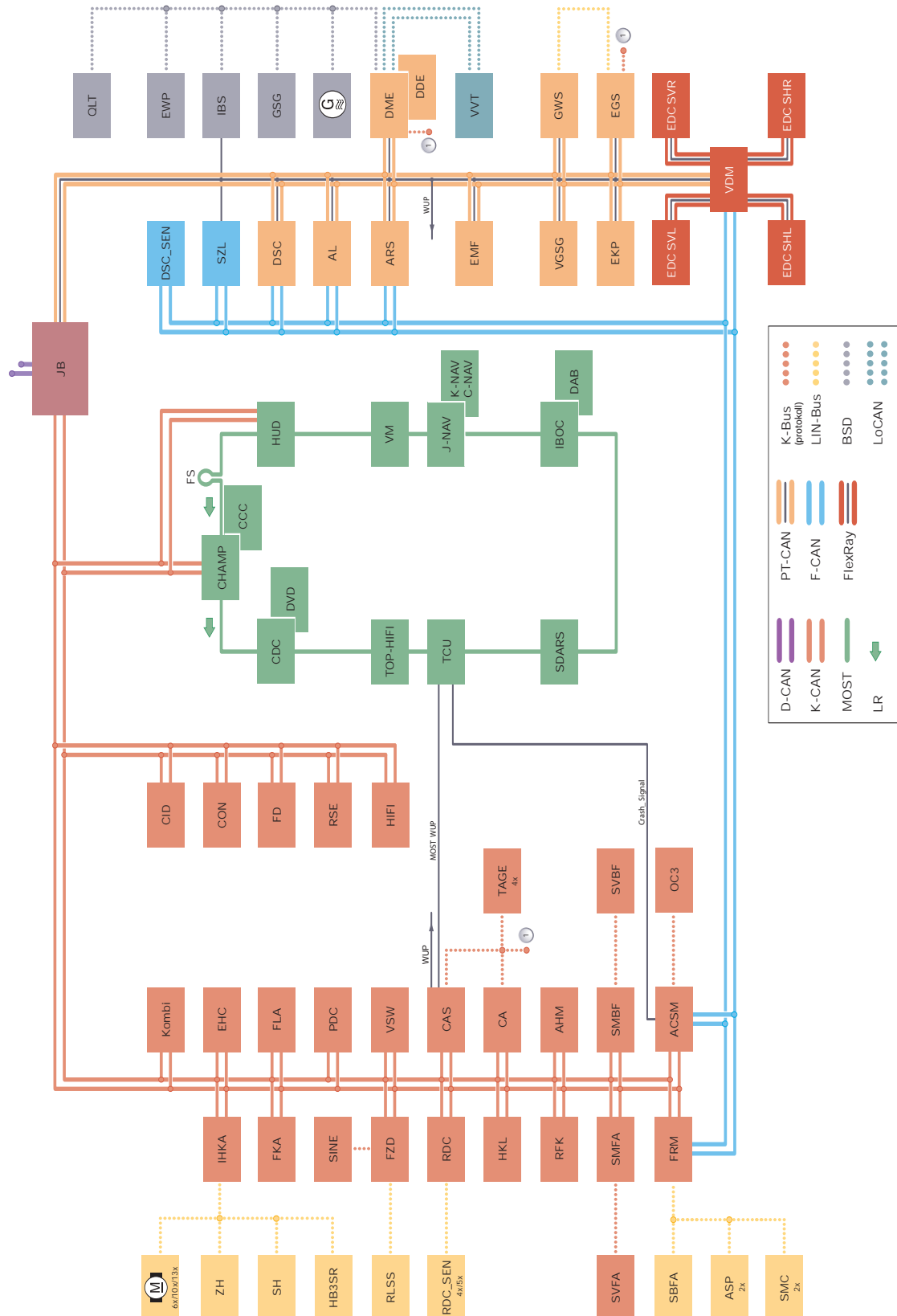

Legend for Bus System Overview

Index	Explanation
ACSM	ACSM control unit
AHM	Trailer module
AL	Active steering system
ARS	Active anti-roll bar
ASP	Outside mirror
CA	Comfort Access
CAS	Car access system
CCC	Car communication computer
CDC	CD changer
CHAMP	Central Head Unit and Multimedia Platform
CID	Central information display
C-NAV	China navigation (will be introduced at a later date)
CON	Controller
DAB	Digital audio broadcasting (will be introduced at a later date)
DDE	Digital diesel electronics
DME	Digital engine electronics
DSC	Dynamic stability control
DSC_SEN	DSC Sensor
DVD	DVD changer (will be introduced at a later date)
EDC SHL	Electronic Damper Control satellite, rear left
EDC SHR	Electronic Damper Control satellite, rear right
EDC SVL	Electronic Damper Control satellite, front left
EDC SVR	Electronic Damper Control satellite, front right
EGS	Electronic transmission control unit
EHC	Electronic Height Control
EKP	Electric fuel pump
EMF	Electromechanical parking brake
EWP	Electric water pump
RD	Rear display
FKA	Rear heater/air-conditioning system
FLA	High beam assistant
FRM	Footwell module
FZD	Roof function center
GSG	Preheater control unit
GWS	Gear selection switch
HB3SR	Heating/ventilation, 3rd row of seats
HiFi	HiFi amplifier
HKL	Tailgate lift
HUD	Head-up display
IBOC	High Definition Radio (will be introduced at a later date)
IBS	Intelligent battery sensor

Legend for Bus System Overview (Cont.)

Index	Explanation
IHKA	Integrated automatic heating/air conditioning system
JB	Junction box control unit
J-NAV	Japan navigation (will be introduced at a later date)
K-NAV	Korea navigation (will be introduced at a later date)
Kombi	Instrument cluster
OC3	Seat occupancy detector mats, US
PDC	Park distance control
QLT	Quality level temperature sensor
RDC	Tire pressure control
RDC_SEN	Tire pressure control sensor
RFK	Reversing camera
RLSS	Rain/driving light solar sensor
RSE	Rear seat entertainment
SBFA	Driver's switch cluster
SDARS	Satellite tuner
SH	Auxiliary heater
SINE	Tilt alarm sensor siren
SMBF	Passenger's seat module
SMC	Stepper motor controller
SMFA	Driver's seat module
SVBF	Front passenger seat adjustment
SVFA	Driver seat adjustment
SZL	Steering column switch cluster
TAGE	Electronic outer door handle module
TCU	Telematics Control Unit
TÖNS	Thermal oil level sensor
TOP-HIFI	Top-HiFi amplifier
VDM	Vertical Dynamic Management (central control unit for Electronic Damper Control)
VGSG	Transfer box control unit
VM	Video module
VSW	Videoswitch
VVT	Variable valve gear
ZH	Electric auxiliary heater

NOTES

PAGE

Components

IKT Component Locations

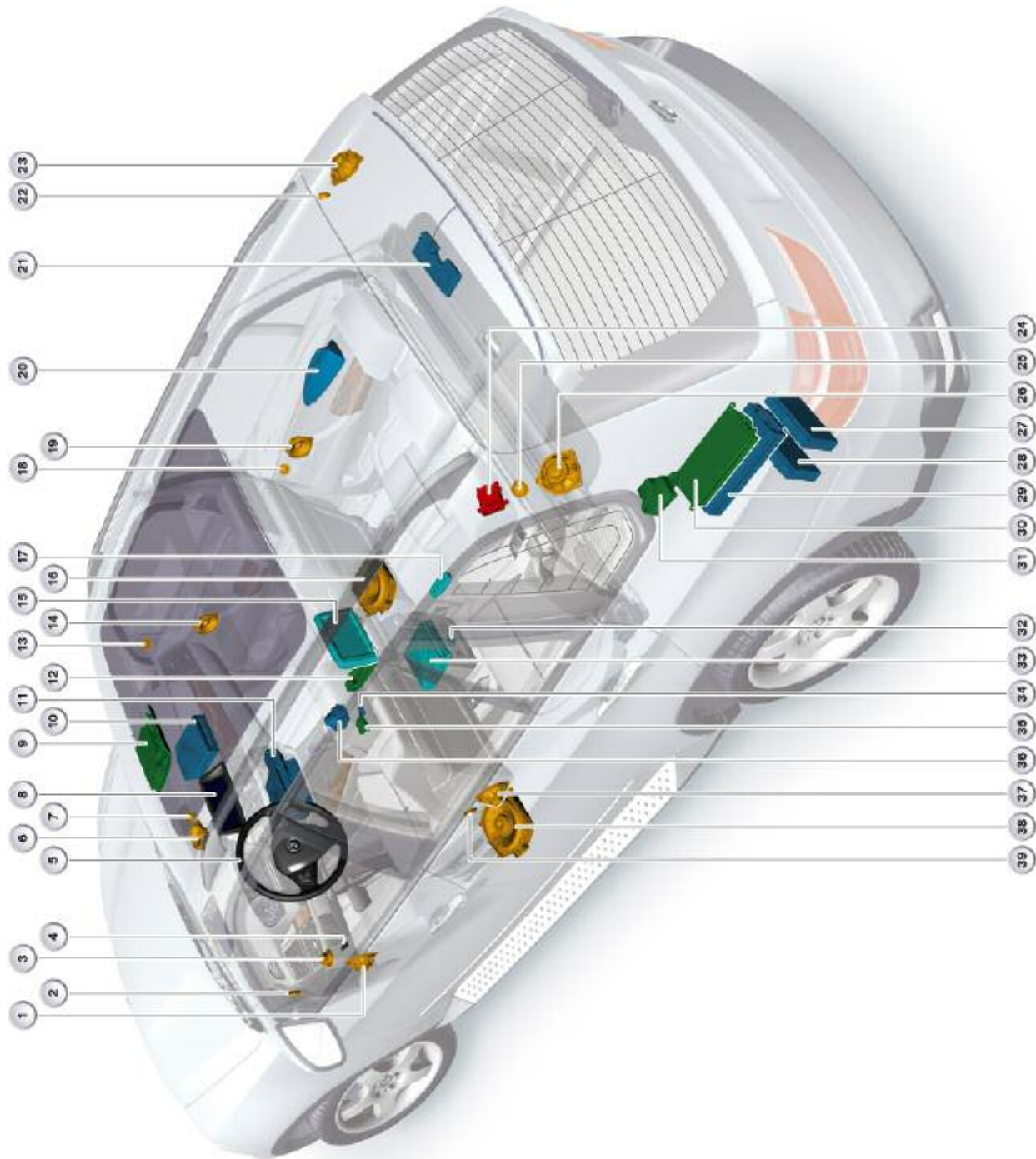

Legend for IKT Component Locations

Index	Explanation	Index	Explanation
1	Broadband speaker or medium-range loudspeaker Left-hand front door	21	Aerial amplifier with diversity module
2	Tweeter, left-hand front door	22	Tweeter, right-hand rear D-post
3	SOS speaker	23	Medium-range loudspeaker, right-hand rear D-post
4	MOST direct access	24	Heated rear window blocking circuit with suppressor filter for additional brake light
5	Multifunction steering wheel (MFL)	25	Tweeter, left-hand rear D-post
6	Mid-range speaker, front center	26	Medium-range loudspeaker, left-hand rear D-post
7	Tweeter, front center	27	Satellite tuner (SDARS)
8	Central information display (CID)	28	High Definition Radio (IBOC)
9	Roof function center (microphone and emergency call button)	29	Audio amplifier (HiFi or Top-HiFi)
10	CD changer (CDC)	30	Telematics Control Unit (TCU)
11	Head Unit	31	SOS antenna
12	Snap-in adapter	32	Head phone connectors
13	Tweeter, right-hand front door	33	Rear seat entertainment (RSE)
14	Broadband speaker or medium-range loudspeaker, right-hand front door	34	Audio jack (AUX-In)
15	Rear display (RD)	35	Bluetooth antenna
16	Central bass speaker, right	36	Controller
17	Radio remote control (RRC) for rear seat entertainment	37	Broadband speaker or medium-range loudspeaker, left-hand rear door
18	Tweeter, right-hand rear door	38	Central bass speaker, left
19	Broadband speaker or medium-range loudspeaker, right-hand rear door	39	Tweeter, left-hand rear door
20	Roof aerial (satellite tuner, GPS, telephone)		

Telematics Control Unit with CHAMP

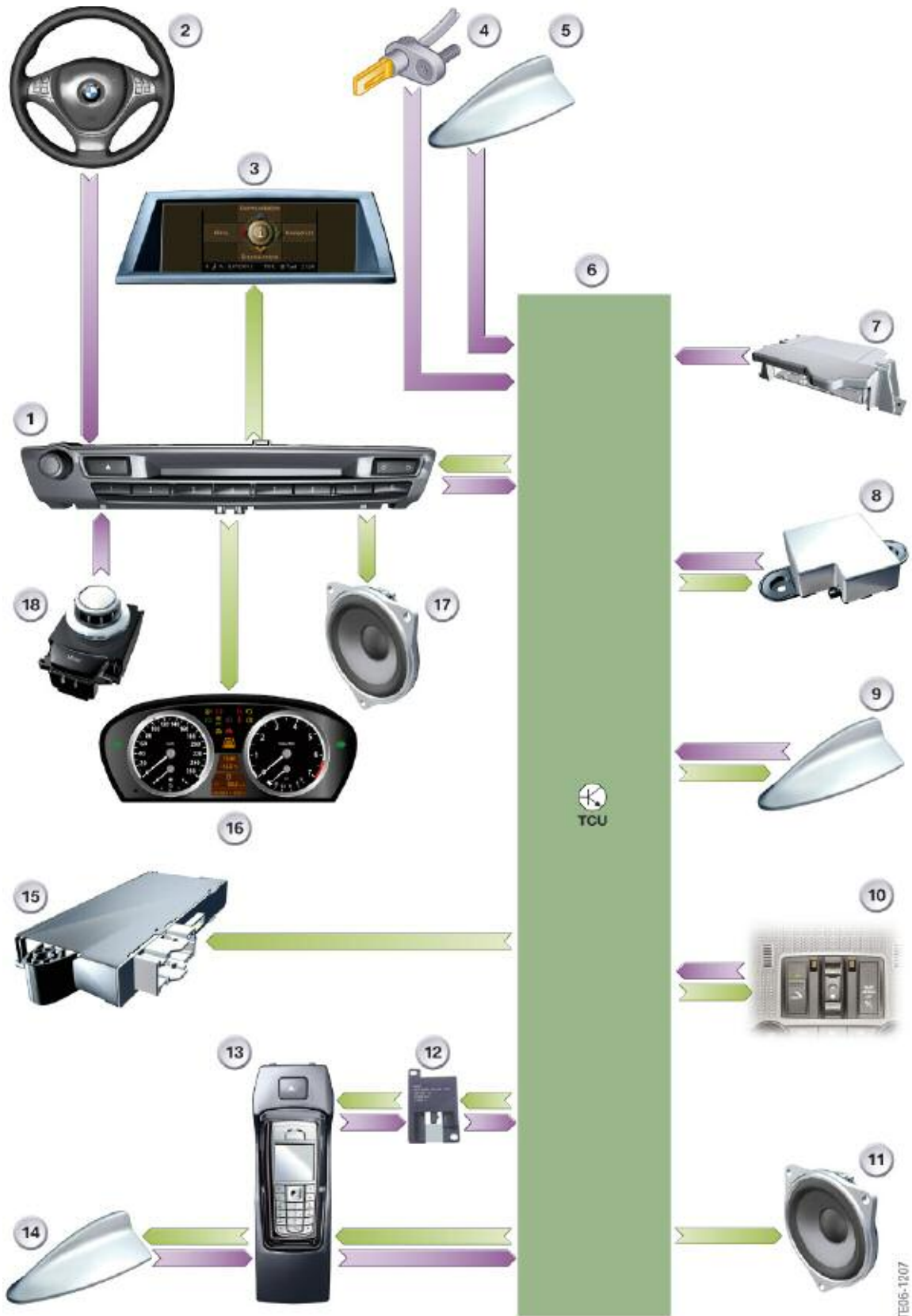

TE06-1207

Telematics Control Unit with CCC



TE306-1222

TCU Input/Output Legend

Index	Explanation	Index	Explanation
1	Head Unit (CCC/CHAMP)	10	Microphone, emergency call button with emergency call indicator lamp in the roof function center
2	Multifunction steering wheel (MFL)	11	SOS speaker
3	Central information display (CID)	12	Bluetooth antenna
4	Wheel speed sensor	13	Snap-in adapter with mobile phone
5	Roof aerial (GPS)	14	Roof aerial (mobile phone)
6	Telematics Control Unit	15	Car Access System (CAS3)
7	Advanced Crash Safety Module (ACSM2)	16	Instrument cluster
8	SOS antenna	17	Audio speaker
9	Roof aerial (TCU)	18	Controller

The legend above applies for the two preceding input/output diagrams. The first one shows the 'Professional' radio option, the second shows the 'Professional' with navigation system.

Note: In the US version, CHAMP is fitted as the "Professional" radio and in the European version, the M-ASK.

The difference between the two items of equipment lies in the activation of the GPS and wheel speed signals. With the 'Professional' radio, both signals are sent to the Telematics Control Unit TCU. With the navigation system, both signals are sent to the Car Communication Computer CCC.

Communication between the mobile phone and the Telematics Control Unit takes place via the Bluetooth interface.

TCU with "Professional" Radio System Circuit Diagram

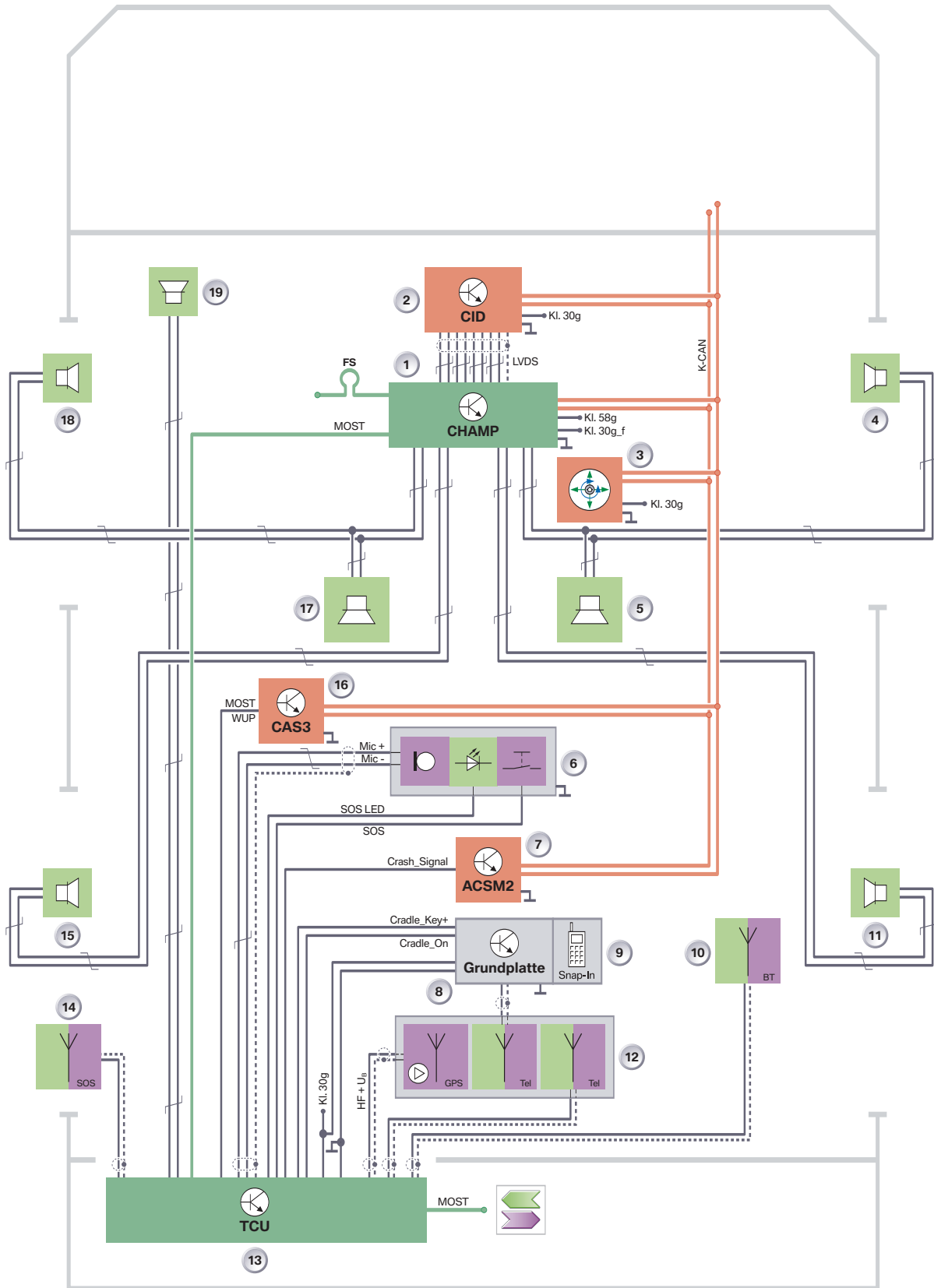

TCU with "Professional" Radio and Navigation Circuit Diagram

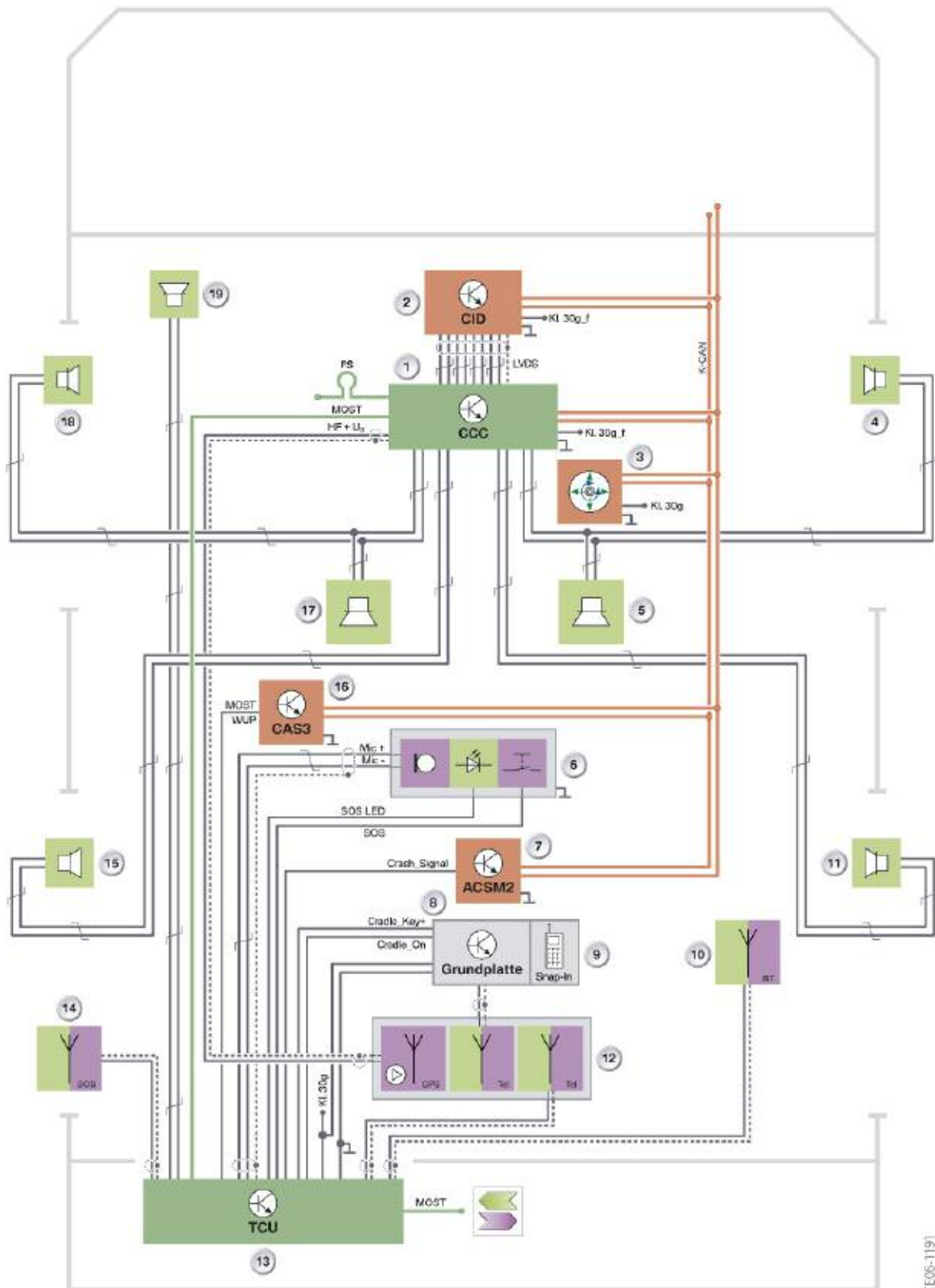

TE06-1191

Legend for Professional Radio/with Navigation Circuit Diagrams

Index	Explanation	Index	Explanation
1	Head Unit	11	Broadband speaker right-hand rear door
2	Central information display	12	Roof aerial (TCU, mobile phone, GPS)
3	Controller	13	Telematics Control Unit
4	Broadband speaker right-hand front door	14	SOS antenna
5	Central bass speaker, right	15	Broadband speaker left-hand rear door
6	Roof function center (microphone, emergency call button with emergency call indicator lamp)	16	Car Access System (CAS3)
7	Advanced Crash Safety Module	17	Central bass speaker, left
8	Base plate	18	Broadband speaker left-hand front door
9	Snap-in adapter with mobile phone	19	SOS speaker
10	Bluetooth antenna	MOST	Media Orientated System Transport (digital bus)
MOST-WUP	Vehicle wake-up signal from the Telematics Control Unit	FS	MOST direct access
LVDS	Low voltage differential signal (digital RGB signal)	Crash_ Signal	Activation of emergency signal
Mic+	Microphone, positive	Mic-	Microphone, negative
SOS LED	Emergency call indicator lamp	SOS	Emergency call signal
Cradle Key+	Handsfree button	Cradle On	ON signal for the charger electronics in the snap-in adapter
HF	High frequency signal	UB	Power supply

Signals and Functions

MOST Signals on the Control Unit TCU			
In/out	Signal	Source/sink	Function
In	GPS signals	> GPS aerial > CCC	Position data
In	Control signals	> Head Unit	Telephone directory, establishing/ending connection, - answering call, emergency call, terminal control,
Out	Audio signals	> Head Unit	Audio signals, call recipient BMW ASSIST
Out	Audio signals	> Head Unit	Audio signals, call recipient mobile phone

Note: The legends apply for the two previous system circuit diagrams.

Thanks to the improved overview, the telephone systems with the stereo systems are shown. The HiFi system is standard equipment in the US version. For more information about these systems, see the "E70 audio systems" Product Information.

Depending on the equipment, the TCU is supplied with power via terminal 30g or terminal 30g_f. A power supply via terminal 30g_f is necessary for provision of the BMW ASSIST services:

- Remote Door Unlock Opening the vehicle doors for servicing
- Stolen Vehicle Recovery

The implementation of the Remote Door Unlock service is carried out via the (MOST) WUP signal. The signal is used to wake up the vehicle. The (TCU) reacts to a call from the provider, performed in the customer order. The (TCU) sends a signal via the (MOST) WUP line to the Car Access System (CAS3). The (CAS3) then wakes up the vehicle.

The CHAMP receives the terminal 58g (lighting) signal via fixed wiring. The CCC receives this signal via the K-CAN.

The eject button on the base board does not receive a signal from terminal 58g. The button is not illuminated.