Table of Contents

E70 Adaptive Headlight System (AHL)

Subject	Page
Introduction	4
Legal Requirement	5
System Overview	6
System Circuit Diagram	6
System Components	9
Control Units	9
Footwell Module	10
Car Access System 3	10
Dynamic Stability Control	10
Rain/driving Lights/Solar Sensor	10
Roof Functions Center	10
Vertical Dynamics Management	10
Bi-Xenon Headlight	11
Rain/Driving Lights/Solar Sensor	11
Roof Functions Center	11
Ultrasonic Passenger-Compartment Sensor	11
Advanced Crash Safety Management (ACSM)	11
Swivel Module for Bi-Xenon Headlight	11
Stepper Motor Controller	12
Side Light/Daytime Driving Light	12
Lights Operating Unit	12
Direction Indicator/High Beam Switch	12
Sensors	13
Yaw Rate Sensor	13
Rotation Rate Sensor	13
Steering Angle Sensor	13
Front and Rear Ride-Height Sensors	13
Brake Pedal Switch	13
Bus Systems	14
Chassis CAN	14
Body CAN	14
LIN-Bus	14
Turn-Off Light	15
Schematic Circuit Diagram - Turn-Off Light	16

Subject	Page
Fog Lights	19
Design of Fog Light	19
Turn-Off Light Reflector	19
Check Control Message	19
Principles of Operation	20
Headlight Swivel Movement	20
Preconditions for the adaptive headlight	20
Switch-On Conditions	20
Switching On Adaptive Headlight	21
Function Indicator	21
Reference Run	21
Zero Position Sensor	21
Mechanical Stop	22
Differential Angle	22
Optical Axis	22
Swivel Range	22
Swivel Direction	22
Traverse Rate	22
Swivelling	23
Stepper Motor Controller	24
Zero Position of Swivel Module	25
Switch-Off Conditions	25
Afterrunning Time	25
Service Information	26
Replacing Components	26
Footwell Module	26
Stepper Motor Controller	26
Bi-Xenon Headlight	26
Diagnosis	27
Malfunction	27
Diagnosis Mode	28

Adaptive Headlight System

Model: E70

Production: From Start of Production

OBJECTIVES

After completion of this module you will be able to:

- Explain the operation of the adaptive headlight system
- Know what components contribute to the adaptive headlamp system

Introduction

The adaptive headlights (AHL) is available as standard equipment. This system is installed only in connection with the bi-xenon headlight.

The adaptive headlight performs the exterior lighting functions. It also enables the bi-xenon low beam and high beam headlight to move within the driving range while cornering.

The AHL feature requires the following:

- Rain/driving light/solar sensor
- Bi-xenon headlight

The swivel range of the bi-xenon low beam and high beam headlight is continuously adapted while cornering. The illuminated area while cornering therefore improves the field of view for the driver.

The adaptive illumination while cornering results in:

- Safer cornering with faster recognition of obstacles
- Improved perception of surroundings
- Accident avoidance



The electronic module of the adaptive headlight facilitates faster response to the current road situation. The system is controlled by the electronic module and is therefore less susceptible than a pure mechanical systems.

In addition, an emergency program can be activated via the electronic module.

Note: The adaptive headlight system is derived from the E90. The footwell module is therefore the central control unit for the adaptive headlight. The adaptive headlight has been adapted for use in the E70.

Legal Requirement

The swivel movement of the adaptive headlight is permitted within certain limits to protect oncoming traffic, i.e. to ensure oncoming traffic is not dazzled by the headlights.

The vehicle moves on a circular path when the driver turns the steering wheel. The circular path is defined by the movement of the wheels and the angle position of the front wheels.

In order not to dazzle the oncoming traffic, the salient point of the light/dark limit of the headlight must not be left of the circular path at a distance corresponding to 100 times the installation height of the headlight.

This conclusion for the light/dark limit refers to right-hand drive traffic. The conclusion relating to the light/dark limit applies symmetrically to left-hand drive traffic.

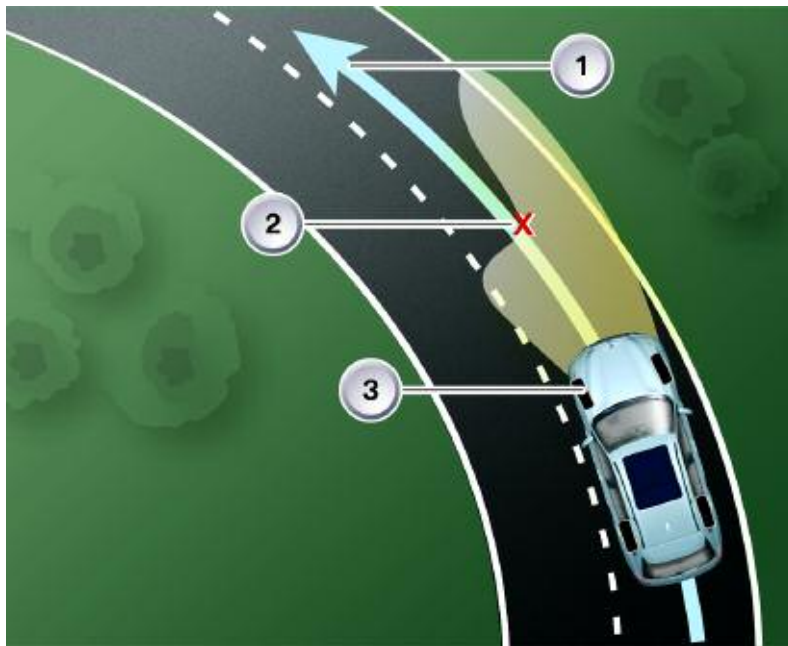

Index	Explanation
1	Anticipated curve
2	Steering lock
3	Steering lock

System Overview

System Circuit Diagram

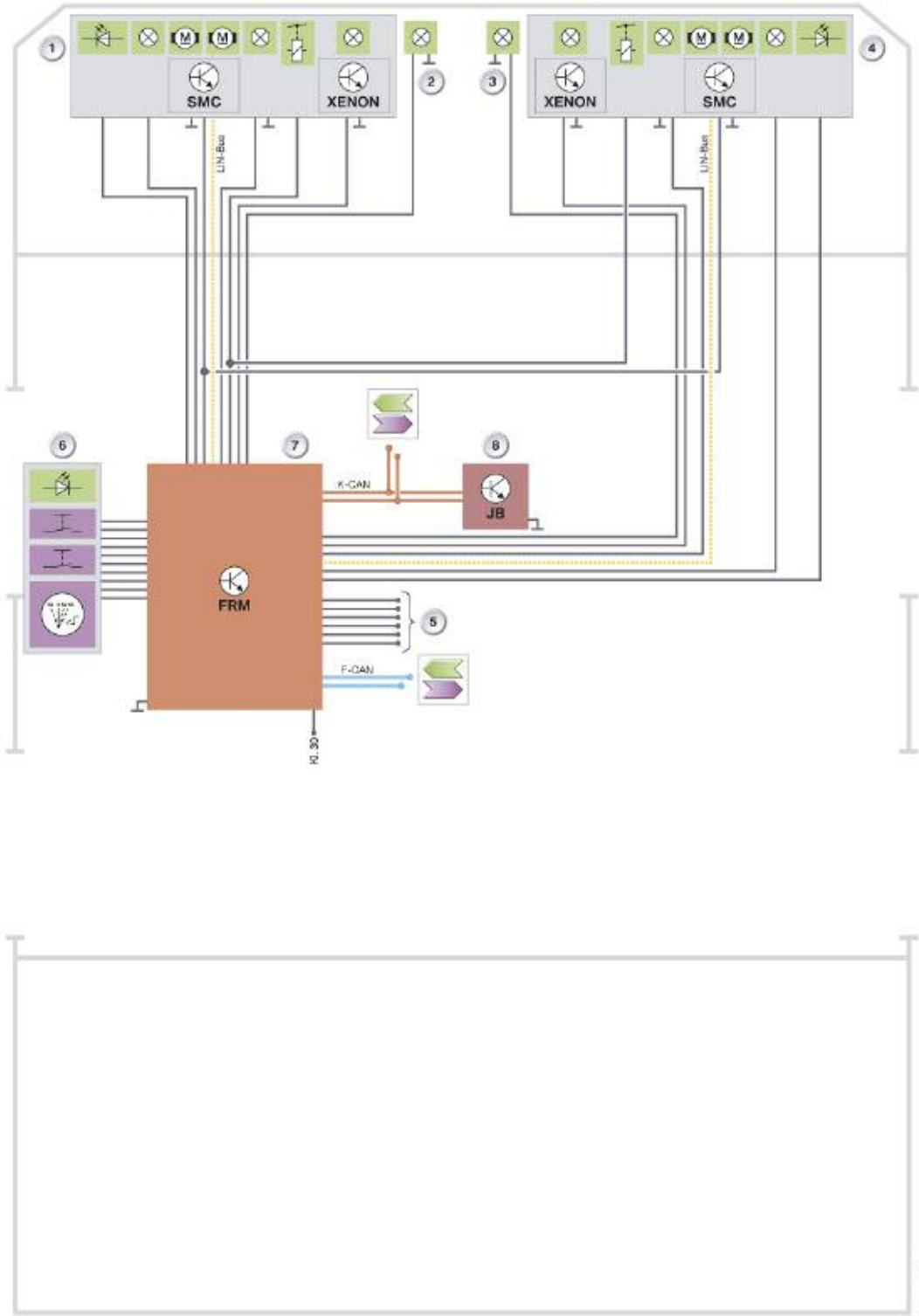

Index	Explanation	Index	Explanation				
1	Main headlight, left	7	Footwell module FRM				
2	Front fog light, left	8	Junction box control unit JB				
3	Front fog light, right	F-CAN	Chassis CAN				
4	Main headlight, right	K-CAN	Body CAN				
5	Connection, ride-height sensors	LIN-Bus	Local Interconnect Network bus				
6	Lights operating unit	KL 30	Terminal 30				
<table border="1"> <tbody> <tr> <td>Main Headlight - Adaptive Headlight, (1 and 4)</td> <td> <ul style="list-style-type: none"> • Side light • Low beam headlight • High beam • Direction indicator • Daytime driving lights • High beam shutter, bi-xenon • Stepper motor, headlight vertical aim control • Stepper motor for adaptive headlight </td> </tr> <tr> <td>Lights operating unit, item number 7</td> <td> <ul style="list-style-type: none"> • Light switch • Fog light button • Rear fog light button • Manual headlight vertical aim control </td> </tr> </tbody> </table>				Main Headlight - Adaptive Headlight, (1 and 4)	<ul style="list-style-type: none"> • Side light • Low beam headlight • High beam • Direction indicator • Daytime driving lights • High beam shutter, bi-xenon • Stepper motor, headlight vertical aim control • Stepper motor for adaptive headlight 	Lights operating unit, item number 7	<ul style="list-style-type: none"> • Light switch • Fog light button • Rear fog light button • Manual headlight vertical aim control
Main Headlight - Adaptive Headlight, (1 and 4)	<ul style="list-style-type: none"> • Side light • Low beam headlight • High beam • Direction indicator • Daytime driving lights • High beam shutter, bi-xenon • Stepper motor, headlight vertical aim control • Stepper motor for adaptive headlight 						
Lights operating unit, item number 7	<ul style="list-style-type: none"> • Light switch • Fog light button • Rear fog light button • Manual headlight vertical aim control 						

Concerning item number 5:

On vehicles with vertical dynamics management, the information relating to the vehicle K-CAN signals at footwell module

K-CAN Signals at the Footwell Module			
In/out	Information	Source/sink	Function
In	Road speed	Wheel speed sensor > dynamic stability control	Calculation of anticipated curve radius in connection with yaw rate
Out	Adaptive headlight defective	Stepper motor controller > footwell module	Check control message in instrument cluster
Out	Fault - adaptive headlight	Footwell module	Check control message in instrument cluster

F-CAN signals at the Footwell Module			
In/out	Information	Source/sink	Function
In	Steering angle	Steering angle sensor > steering column switch cluster	Swivel movement of adaptive headlight
In	Yaw rate	Yaw rate sensor > dynamic stability control	Calculation of anticipated curve radius in connection with vehicle speed
In	Vehicle level	VDM sensors > vertical dynamics management	Headlight vertical aim control

System Components

Depending on the equipment configuration of the vehicle, the following system components may be installed for the adaptive headlight function.

- Control units
 - Footwell module
 - Car Access System 3
 - Dynamic stability control
 - Rain/driving lights/solar sensor
 - Roof functions center
 - Vertical dynamics management
- Bi-xenon headlight
- Lights operating unit
- Direction indicator/high beam switch
- Sensor systems
 - Yaw rate sensor, steering angle sensor
 - Front and rear ride-height sensors
 - Brake pedal switch

Control Units

The footwell module is the central control unit for the entire exterior lighting system and therefore also for the adaptive headlight. The other control units such as the dynamic stability control provide input signals.

Control Unit	Signal
Car Access System 3	Wake-up
Dynamic stability control	Vehicle speed and yaw rate
Rain/driving lights/solar sensor	Switch on lights when dark
Roof functions center	Transfer of RLSS signal to K-CAN
Vertical dynamics management	Vehicle level

Footwell Module

The control for the adaptive headlight is located in the footwell module.

The footwell module is connected to three bus systems,

The bus systems are:

- K-CAN
- F-CAN, e.g. if vertical dynamics management is installed
- LIN-bus

Data from the vertical dynamics management system are received via the F-CAN. The footwell module receives and sends data via the K-CAN and LIN-bus.

Note: The footwell module has no gateway for the F-CAN, however, it does have the gateway between K-CAN and LIN-bus.

Car Access System 3

The Car Access System 3 sends the wake-up signal to the control unit in the vehicle. The steering column switch cluster is connected directly to the wake-up line.

Dynamic Stability Control

The dynamic stability control sends signals relating to the yaw rate and vehicle speed to the adaptive headlight.

Rain/driving Lights/Solar Sensor

The rain/driving lights/solar sensor sends the request to switch on the low beam headlights as soon as it detects low light levels (darkness). The light switch must be set to automatic high beam control for this purpose.

Roof Functions Center

The roof functions center receives the signals from the rain/driving light/solar sensor. The roof functions center makes the signals available on the K-CAN.

Vertical Dynamics Management

Vertical dynamics management makes available the values for the dynamic headlight vertical aim control to the footwell module.

The footwell module receives these values via the F-CAN. In this way the headlight range can be adapted to the different driving situations, e.g. laden/unladen.

Bi-Xenon Headlight

Each bi-xenon headlight contains following components:

- Swivel module for bi-xenon headlight
- Stepper motor controller
- Stepper motor for headlight vertical aim control
- Side light corona/daytime driving light corona
- Direction indicator
- Bi-xenon control unit

Rain/Driving Lights/Solar Sensor

The rain/driving lights/solar sensor is fitted in the mirror base. The signals from the rain/driving lights/solar sensor are used to switch on the automatic driving lights.

Roof Functions Center

The roof functions center is the gateway for the rain/driving lights/solar sensor. It transfers the LIN-bus signal of the rain/driving lights/solar sensor to the K-CAN.

Ultrasonic Passenger-Compartment Sensor

The ultrasonic passenger compartment sensor signals the visual alarm of the anti-theft alarm system via the K-CAN. The visual alarm depends on the country-specific version.

Note: The ultrasonic passenger compartment sensor is integrated in the roof functions center.

Advanced Crash Safety Management (ACSM)

The advanced crash safety management sends signals in the event of an accident. This allows the footwell module to trigger the visual signalling (e.g. hazard warning lights ON).

Swivel Module for Bi-Xenon Headlight

Among other things, the swivel module contains following components:

- Bi-xenon lamp
- Hall sensor for zero position
- Stepper motor

The bi-xenon headlight control unit is mounted on the bi-xenon headlight. It supplies the power and ignition voltage for the bi-xenon light bulb. The bi-xenon light bulb is integrated in the swivel section of the adaptive headlight.

The zero position Hall sensor registers the zero position of the swivel module.

The stepper motor provides the swivel movement of the swivel module. A separate stepper motor is installed for the headlight vertical aim control.

Stepper Motor Controller

The stepper motor controller is mounted on the side of the bi-xenon headlight.

The stepper motor controller controls and monitors the movement of the stepper motors for the adaptive headlight and the vertical aim control system.

Side Light/Daytime Driving Light

The side light/daytime driving light is designed as a fiber optics light guide ring. A 35 W bulb (H8) supplies the light to the fiber optics ring from below.

Lights Operating Unit

The light switch must be set to automatic driving lights control in order to switch on the adaptive headlight. The lights operating unit is connected to the footwell module.

The light switch can be pressed in at a certain pressure in forward direction. This increases the impact surface area in the vicinity of the light switch in the event of an accident thus contributing to improved passenger protection.

Direction Indicator/High Beam Switch

The steering column switch cluster contains the direction indicator/high beam switch. The steering column switch cluster makes available the signal from the direction indicator/high beam switch hard-wired to the footwell module. A more detailed description of the steering column switch cluster can be found in the Product Information "Steering column switch cluster E70".

Sensors

Yaw Rate Sensor

The yaw rate sensor makes available signals relating to the yaw of the vehicle about the vertical axis.

The yaw rate sensor is installed on the driveshaft tunnel between the driver's and passenger's seat next to the advanced crash safety management ACSM.

Rotation Rate Sensor

The rotation rate sensors supply the signals for the vehicle speed. The dynamic stability control evaluates the sensor of each wheel.

Steering Angle Sensor

The steering angle sensor is integrated in the steering column switch cluster. It is an optical sensor and makes available data relating to the steering wheel lock angle.

A more detailed description of the steering angle sensor can be found in the Product Information "Steering column switch cluster E70".

Front and Rear Ride-Height Sensors

The signals of the ride-height sensors are used for the headlight vertical aim control LWR.

The ride-height sensors are connected directly to the footwell module.

Note: If vertical dynamics management is installed, the information relating to the vehicle ride height is made available via the F-CAN.

Brake Pedal Switch

The signal of the brake pedal switch is used for the headlight vertical aim control (LWR).

Bus Systems

The footwell module is connected to three bus systems, via which the adaptive headlight receives input signals.

The bus systems are:

- Chassis-CAN F-CAN
- Body-CAN K-CAN
- Local Interconnected Network Bus (LIN-Bus)

Chassis CAN

The F-CAN is connected to the footwell module for the purpose of transferring data from the steering angle sensor. The signal path runs from the steering angle sensor in the steering column switch cluster via the F-CAN to the dynamic stability control, which in turn transfers the signal to the F-CAN.

If vertical dynamics management is installed, the footwell module receives the data for the dynamic headlight vertical aim control via the F-CAN. The data transfer rate is 500 kBd.

Body CAN

The footwell module receives information, e.g.

"Terminal 15 ON", which is important for operation of the adaptive headlight, via the K-CAN.

The K-CAN has a data transfer rate of 100 kBd.

LIN-Bus

The LIN-bus has a data transfer rate of 19.2 kBd. It connects the stepper motor controllers to the footwell module.

Turn-Off Light

The turn-off light function is available only in connection with the option SA 524 Adaptive Headlight. In addition to the adaptive headlight, the turn-off light additionally illuminates the area in front of and beside the vehicle.

The turn-off light makes it possible to recognize persons or traffic situations earlier in the turn-off area.

Parameters such as the steering angle and vehicle speed are taken into account for the turn-off light function. The turn-off light is integrated in the fog lights.

This is due to the fact that the installation position of the headlights in the X5 is too high for the turn-off light function and would not conform to legal requirements.



The turn-off light function is integrated in the fog light. This function is active only in position "A" of the light switch.

1



2

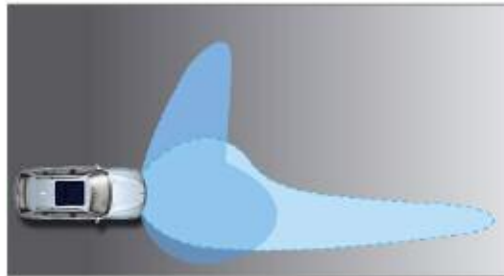

Illumination with Turn-Off Light

Index	Explanation	Index	Explanation
1	Without Cornering Lights	2	With Cornering Lights On

Schematic Circuit Diagram - Turn-Off Light

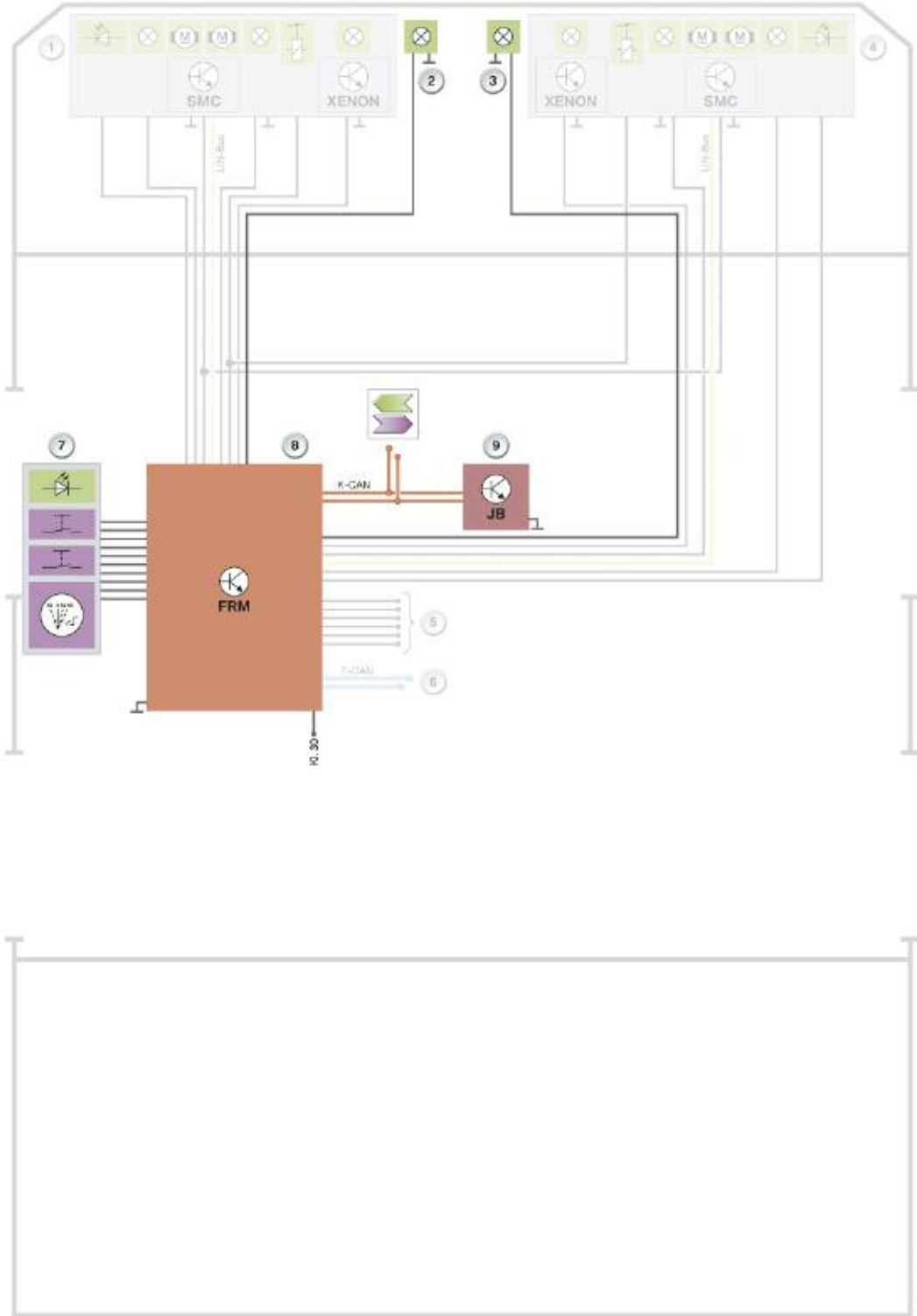

Legend for Schematic Circuit Diagram - Turn-Off Light

Index	Explanation	Index	Explanation
1	Main headlight, left	7	Lights operating unit
2	Front fog light, left	8	Footwell module FRM
3	Front fog light, right	9	Junction box control unit JB
4	Main headlight, right	KL 30	Kl. 30 Terminal 30
5	Line to ride-height sensors	K-CAN	K-CAN Body CAN
6	F-CAN connection	LIN-Bus	LIN-Bus Local interconnect network bus

Signals via the F-CAN and K-CAN			
In/out	Information	Source/sink	Function
In	Road speed	Rotation rate sensor > dynamic stability control	Switch on turn-off light (switch on criterion of turn-off light)
In	Steering angle	Steering angle sensor > steering column switch cluster > F-CAN	Switch on turn-off light (selection criterion of turn-off light)
In	Reverse gear engaged	Gear selector lever switch > electronic transmission control > PT-CAN > junction box control unit > K-CAN	Switch on turn-off light (switch on criterion of turn-off light)
In	Switch on direction indicator	Steering column stalk, direction indicator > steering column switch cluster > F-CAN	Switch on turn-off light (selection criterion of turn-off light)

The low beam headlight must be switched on by the automatic driving light control function for the turn-off light to be activated. The turnoff light is activated only under the following conditions.

Function matrix for activation of the turn-off light:

Driving Direction	Condition	Side with Activated Turn-Off Light
Forward	<ul style="list-style-type: none"> •Speed below 40 km/h •Direction indicator activated 	Same side as activated direction indicator
Forward	<ul style="list-style-type: none"> •Speed below 40 km/h •Direction indicator activated 	On side in direction of steering lock
Reverse	<ul style="list-style-type: none"> •Speed below 40 km/h •Reverse gear activated •Direction indicator activated 	Same side as activated direction indicator
Reverse	<ul style="list-style-type: none"> •Speed below 40 km/h •Reverse gear activated •Steering lock 	Opposite side in direction of steering lock
Reverse	<ul style="list-style-type: none"> •Vehicle speed below 65 km/h •Reverse gear activated 	Both Sides

Note: The turn-off light is no longer switched off if only one signal fails, e.g. due to a defect. A special feature of the turn-off light in the E70 is that it is integrated in the fog light. The fog light with turn-off light function can be recognized from the outside by the fact that the reflector is completely chrome-plated.

Fog Lights

Design of Fog Light

A special fog light is necessary for the turn-off light. It contains the reflector for the turn-off light.

Index	Explanation
1	Turn-Off Light Reflector
2	Fog Light Reflector
3	Fog Light Bulb

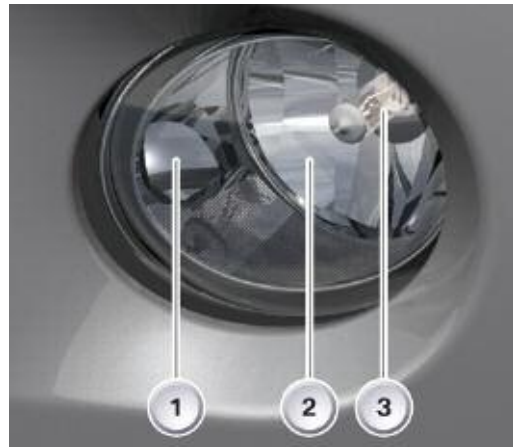

■ Turn-Off Light Reflector

The light from the fog light bulb reaches the reflector for the turn-off light as soon as the fog light is switched on. The reflector is specially shaped and reflects the light in the turn-off area.

Index	Explanation
1	Turn-Off Light Reflector
2	Fog Light Reflector
3	Light Path

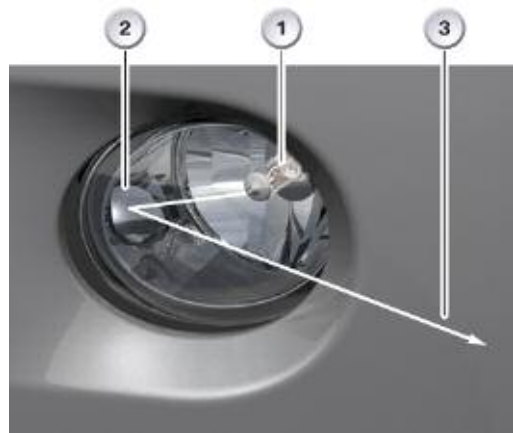

Check Control Message

The same check control messages apply as for the fog lights.

Principles of Operation

Headlight Swivel Movement

Preconditions for the adaptive headlight

To ensure its operability, the adaptive headlight must be adapted to the vehicle specific data. The vehicle-specific data are located in the footwell module and in the stepper motor controllers.

The footwell module contains the data:

- Vehicle identification number
- Vehicle type

The stepper motor controller contains the data for:

- Headlight and headlight swivel range
- Permitted acceleration and deceleration ramps
- Characteristic speed maps
- Encoding
- Vehicle identification number
- Vehicle type

Switch-On Conditions

The adaptive headlight can be activated as from terminal status "terminal 15 ON".

Initially, the footwell module switches on the stepper motor controllers. The adaptive headlight is ready for operation following a reference run of the bi-xenon headlights.

Note: A reference run is performed during every new start.

The conditions for switching on the adaptive headlight are:

- "Terminal 15 ON"
- Light switch in automatic driving light control position
- Rain/driving lights/solar sensor detects darkness
- Both bi-xenon headlights are intact

Note: The footwell module detects a defective bi-xenon headlight by measuring the intake current of the respective bi-xenon headlight.

Switching On Adaptive Headlight

The adaptive headlight is switched on as soon as the rain/driving lights/solar sensor sends the switch-on signal for the low beam headlight.

Function Indicator

Operation of the adaptive headlight is indicated by permanent activation of the LED for automatic driving light control.

However, if the LED for the automatic driving light control flashes while the adaptive headlight is active, this indicates that there is a fault in the adaptive headlight.

The low beam headlight and the headlight vertical aim control remain active in the case of fault. The swivel function of the bi-xenon modules is deactivated.

The light switch must be in the automatic driving lights control position.

Reference Run

In order to determine the zero position, the adaptive headlight performs a reference run depending on the current position of the swivel module.

To avoid a hysteresis during calibration, the swivel module always moves from the same side over the zero position sensor.

This is achieved in that the swivel module is always moved to the same side of the zero position sensor before switching off the adaptive headlight.

Zero Position Sensor

The zero position of the swivel module with respect to the zero position sensor is detected by a 1/0 edge when swivelling from the direction of the off position in the direction of the optical axis. The swivel module is repeatedly calibrated during operation based on this "soft" reference point.

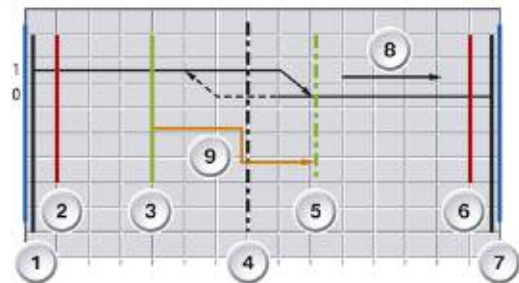

Index	Explanation	Index	Explanation
1	Mechanical stop, minimum	6	Electrical stop, maximum
2	Electrical stop	7	Mechanical stop
3	OFF position	8	Swivel direction
4	Position of zero position sensor	9	Reference run from left
5	Position of optical axis = 0		

Mechanical Stop

Items 1 and 7 represent the mechanical stops of the swivel module. The mechanical stops are defined by the design of the headlights.

Differential Angle

A differential angle is required when the position of the swivel module is not known. A reference run that extends to the mechanical stops must be performed for this purpose.

This is known as a "hard" reference run.

Optical Axis

The swivel position, in which the swivel module is in the straight-ahead direction of the vehicle is referred to as the optical axis. An angle of 0° is assigned to this position.

The optical axis is defined exactly as an angle with respect to the zero position sensor and as an angle with respect to the mechanical stop.

Consequently, the optical axis during swivel movement can be "normally" determined by way of the zero position sensor.

The differential angle with respect to the mechanical reference point is used in the case of fault.

Swivel Range

Normally, the swivel module does not extend to the mechanical stop but rather to the electric minimum and maximum stop.

Adjustment of the swivel module to the electrical stops avoids the loss of pulses on reaching a mechanical stop.

The minimum and maximum electrical stops are defined as angles with respect to the zero position.

The movement range of the headlights is 8° with respect to the vehicle center and 15° to the outside. The swivel range is not restricted by mechanical tolerances.

Swivel Direction

Driving the stepper motor in positive direction of the swivel module corresponds to swivel movement to the right.

Traverse Rate

The traverse rate of the swivel modules is up to $30^\circ/\text{s}$.

Swivelling

The following signals are made available to the footwell module for the purpose of moving the swivel module.

- Steering angle
- Road speed
- Yaw rate

Under normal driving conditions, the adaptive headlight is controlled by the data from the steering angle sensor up to a speed of approximately 40 km/h.



Index	Explanation
1	Vehicle Speed
2	Steering Angle
3	Yaw Rate

The yaw rate sensor is included in the calculation:

- at speeds higher than approximately 40 km/h
- in the event of vehicle oversteering or understeering
- a vehicle tending to yaw

The vehicle oversteering/understeering or yawing is detected by means of the steering angle sensor and the yaw rate sensor.

The adaptive headlight is deactivated in the event of the vehicle oversteering/understeering or yawing. The swivel module returns to its zero position.

Stepper Motor Controller

The stepper motor controller controls and monitors the stepper motors for the adaptive headlight and the headlight vertical aim control of the respective bi-xenon headlight.

The stepper motor controller performs following functions:

- Receiving and evaluating the data sent from the footwell module via the LIN-bus:
 - Reference run
 - Target position commands
 - Diagnosis requests
- Output control of the stepper motors
- Zero position acquisition of swivel module
- Reference run of swivel module
- Position feedback of swivel module to footwell module
- Diagnosis
- Feedback of diagnosis data to the footwell module

The footwell module in its function as the central control unit for the adaptive headlight checks the status of the stepper motor controllers every 20 ms.

Stepper Motor Controller

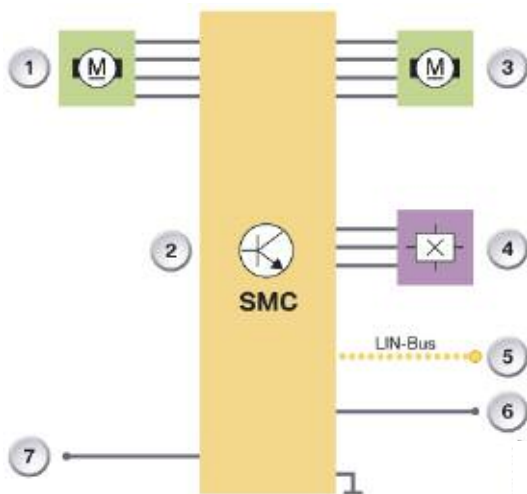

Index	Explanation
1	Stepper motor for adaptive headlight
2	Stepper motor controller
3	Stepper motor, headlight vertical aim control
4	Zero position sensor
5	LIN-Bus
6	Coding pin for right/left
7	Voltage supply +

Zero Position of Swivel Module

The zero position of the swivel module is determined by the zero position sensor. The zero position sensor is a Hall sensor. The falling edge of the Hall sensor is evaluated to determine the zero position. The zero position corresponds to exactly the position of the swivel module in the straight-ahead position of the vehicle.

The stepper motor controller prepares the data for data transfer via the LIN-bus. The footwell module requests the data from the stepper motor controller.

Note: The sensor signal can be read out during diagnosis. The sensor is defective if no sensor signal is applied.

Switch-Off Conditions

As from "terminal 15 OFF", the footwell module sends the request via the LIN bus to assume the rest position of both swivel modules to the stepper motor controllers.

On reaching the rest position of the swivel modules, the stepper motor controllers send an acknowledgement to the footwell module. On receiving the acknowledgement, the footwell module switches off the stepper motor controllers.

Afterrunning Time

The afterrunning time is 2 s.

Service Information

Replacing Components

Various repairs may be necessary during the course of the vehicle's service life. As a consequence of repair work, it is possible that the system components for the adaptive headlight are installed with different software and hardware versions.

New and/or used parts are used together with the components already installed in the vehicle.

In each case, the replaced components must be adapted to the specific requirements of the vehicle.

The following components can be replaced as part of servicing:

- Footwell module
- Stepper motor controller
- Bi-xenon headlight
- Bi-xenon headlight retrofit

Footwell Module

After replacing an footwell module, it is necessary to enter the vehicle identification number and to encode the control unit depending on specific vehicle data.

The complete adaptive headlight function will not be operative if adaptation to the vehicle is not performed.

Stepper Motor Controller

After replacing the stepper motor controllers, it is necessary to store the vehicle identification number and enter headlight related coding in the stepper motor controllers.

The complete adaptive headlight function will not be operative without this adaptation.

Particular care must be taken when replacing the stepper motor controllers to ensure that the housing gasket of the stepper motor controller is fitted and seals correctly.

Bi-Xenon Headlight

After replacing the bi-xenon headlights, headlight-specific encoding is necessary for the respective stepper motor controller.

If this adaptation is not performed, the function will appear to be operative but not correct.

The swivel range and zero point can vary from vehicle model to vehicle model and the bi-xenon headlight can have a different status!

The headlights must be adjusted and checked.

Diagnosis

Malfunction

Malfunctions that may cause the adaptive headlight system to fail are listed in the following:

Number	Description
1	Step error within the specified tolerance range Yes Self-adjustment every time a level change of the position sensor is detected.
2	Step error outside the specified tolerance range Yes Swivel range mechanically restricted, swivel module is moved to zero position, the swivel function is disabled, headlight vertical aim control remains active.
3	LIN-bus failure Yes Stepper motor controller: Emergency program. Footwell module: Error signal to indicator lamp, if possible move the stepper motor controller that is still operable in the optical axis position, headlight vertical aim control remains active.
4	UB- or GND and failure for stepper motor controller Yes Stepper motor controller: Operation not possible, system shuts down. There is no emergency power supply. FRM: Error signal to indicator lamp, nevertheless the stepper motor controller that is still operable is moved to the optical axis position and the swivel function is deactivated; headlight vertical aim control remains active. The corresponding headlight is deactivated as required.
5	Position sensor defective Swivel motor defective Turning mechanism defective It is not possible to distinguish between a position sensor defect and a mechanical swivel motor defect. Absence of level change of sensor signal within the specified tolerance range. Stepper motor controller: Emergency shut-down of swivel function. Low beam headlight disabled on affected side if there is a risk of dazzling. Fog lights switched on as substitute function Telegram to footwell module The dazzle effect may be avoided by lowering the headlight range using the vertical aim control.
6	Swivel motor electrically defective, short-circuit or break It is not possible to distinguish between the actual motor failure and a defect in the supply line. Immediate shut-down of the swivel function. After evaluating the position sensor, in the event of possibly dazzling the oncoming traffic, the headlight range is reduced or the headlight is switch off via the vertical aim control.
7	Motor for headlight vertical aim control electrically defective, short-circuit or break Yes Immediate shut-down of the headlight vertical aim control function.

Diagnosis Mode

The adaptive headlight must be set to diagnosis mode for following diagnosis tasks:

- Read out of relevant bus signals with vehicle stationary
 - Road speed
 - Yaw rate
 - Steering angle
- Checking signal plausibility
- Checking that conditions for activation are fulfilled
 - Rain/driving lights/solar sensor status
 - Light switch status

Missing or non-plausible BUS signals are stored in the form of fault codes in the footwell module. The fault types are stored in the stepper motor controller.

The stepper motor controller is accessed via the footwell module.