Table of Contents

E70 Transmissions

Subject	Page
New Transmissions for E70	5
Changes	5
Technical Data	6
Gearbox Variant	6
Electronic Transmission Control	8
Gear Selector Lever (GWS)	10
Operation and Functions	10
Haptic Locks	11
Manual Gate, Sport Program (M/S)	13
Parking Lock "P"	13
Automatic Downshift from "M/S"	13
Interface to EGS	14
Definition of Messages	14
Communication	14
Safe Status for Sending	14
Indicator in the Gear Selector Lever	15
Flashing of a Position LED	15
Indicator Flashing Through Diagnosis	15
Secure Indicator Status	15
Park and Unlock Button	16
Evaluating the P-button	16
Evaluating the Unlock Button	17
Components	17
Sensors	17
Actuators	17
Emergency Release of Parking Lock	18
GA6HP19/26TU Gearbox	19
Casing and Intermediate Plate	19
Torque Converter	20
Clutches	21
Mechatronics Module	22
Converter lockup clutch connection stages	22
Target gear allocation dependent on accelerator pedal gradient	24
Shift Speed Characteristics	26
Torque Intervention	26
LIN-Bus Module	26

Subject	Page
Electronic-hydraulic Control	26
Torque Converter Control	27
Variable Cooling Oil Flow	27
System Pressure in Reverse Gear	28
Clutch Valves	28
Solenoid Valves (MV)	28
Electronic Pressure Control Valves (EDS)	28
Gear Selector Lever	30
Emergency Release of Parking Lock	30

BLANK
PAGE

Transmissions

Model: E70

Production: From Start of Production

OBJECTIVES

After completion of this module you will be able to:

- Describe changes to E70 Automatic Transmissions
- Understand GWS Operation

New Transmissions for E70

The GA6HPTU gearbox is a further development of the known automatic gearbox GA6HP. The re-engineered automatic gearbox provides a distinct boost in dynamics while at the same time improving fuel consumption and pollutant emission.

The E70 is equipped with an electric gearshift system similar to the system in the E65. In this case, however, the automatic gearbox is not operated from a steering column stalk but rather from a selector lever that is located in the standard position on the center console.



The shift pattern is largely modeled on a conventional gearshift with mechanical link to the automatic gearbox. The electronic transmission control (EGS) has been adapted to the changes/modifications.

This reference manual only deals with the changes and modifications to the GA6HP gearbox.

Changes

The automatic gearbox GA6HPTU for the E70 has been reengineered in terms of the following points:

- Torque converter with turbine-torsion damper
- Clutch E
- Adapted electronic transmission control (EGS)
- Faster hydraulics through new pressure regulator
- Electric gearshift

Technical Data

	GA6HP19TU	GA6HP26TU
Type of gearbox	Passenger vehicle automatic gearbox with 6 forward speeds and 1 reverse gear in standard arrangement.	
Transmission output in [kW]	225	300
Transmission output in [Nm]	400	650
Torque converter	W240R TTD	W270RH-4GWK TTD
Maximum permissible continuous speed of torque converter in rpm	7000	7000
Transmission Ratios		
1st gear	4.171	
2nd gear	2.340	
3rd gear	1.521	
4th gear	1.143	
5th gear	0.867	
6th gear	0.691	
Reverse	3.403	
Gearbox weight (kg) including oil	77.0	92.0
Control	Electro-hydraulic with electronic transmission control	
Towing range	500 km at up to 80 km/h	500 km at up to 80 km/h
Maximum uphill/downhill gradient while driving	50%	50%
Maximum uphill gradient, starting off (in forward or reverse)	32%	32%

Gearbox Variant

	Model	Engine	Transmitted torque
GA6HP19TU	X5 3.0i (E70)	N52B3001	400 Nm
GA6HP26TU	X5 4.8i (E70)	N62B4801	650 Nm

NOTES

PAGE

Electronic Transmission Control

The following diagram shows the interconnection of the electronic transmission control with the gear selector lever and the interfaces in the vehicle.

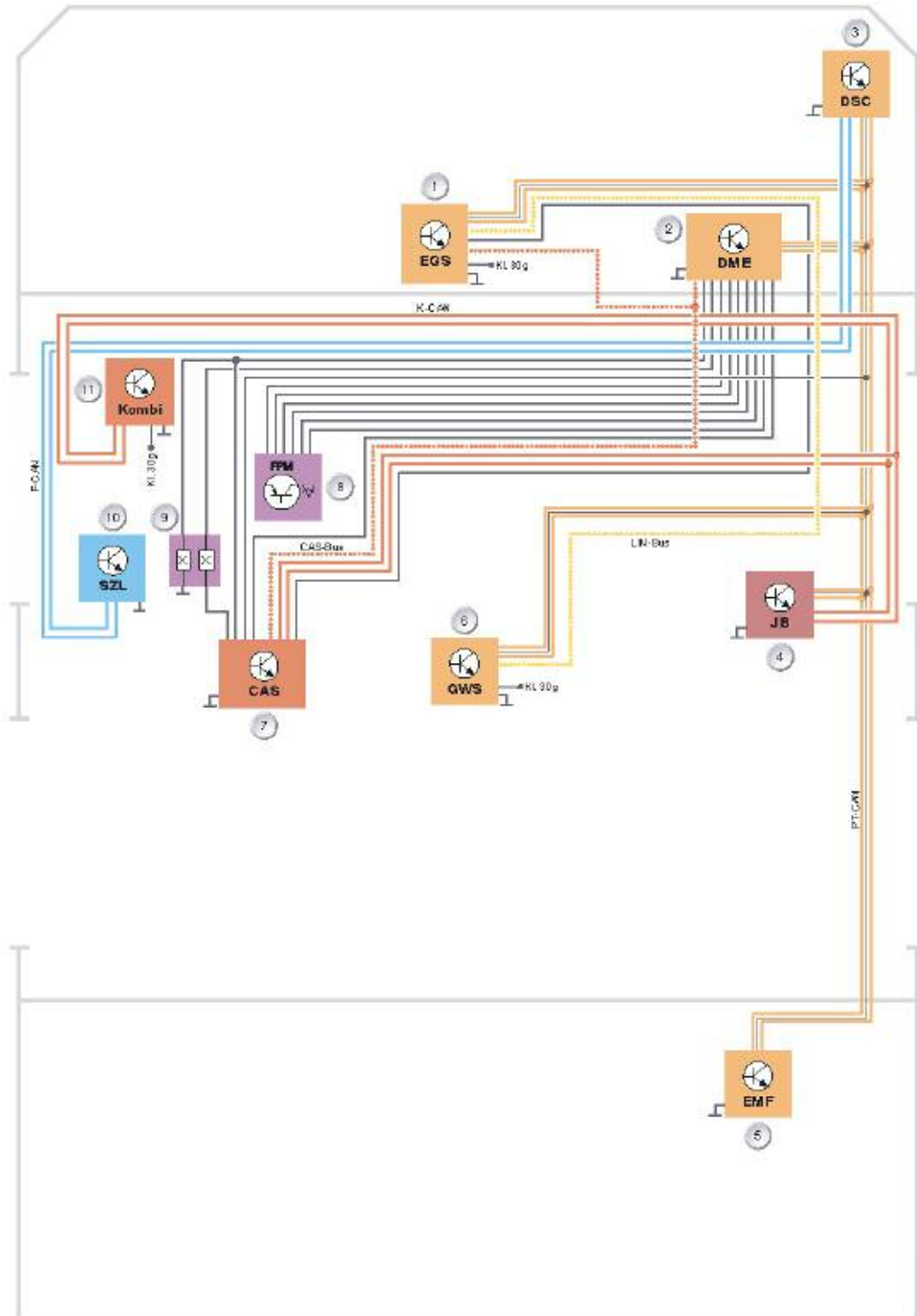

Index	Explanation	Index	Explanation
1	EGS control module	7	Car Access System (CAS)
2	DSC control module	8	Accelerator pedal module
3	ECM (DME)	9	Brake light switch
4	Junction Box control unit	10	Steering column switch cluster
5	EMF	11	Instrument cluster
6	Gear Selector Lever (GWS)		

Gear Selector Lever (GWS)

The automatic gearbox in the E70 is operated by means of an electric gearshift system. This system is already known from the E65. Unlike in the E65, the gear selector lever in the E70 is not on the steering column but rather in the usual position on the center console.

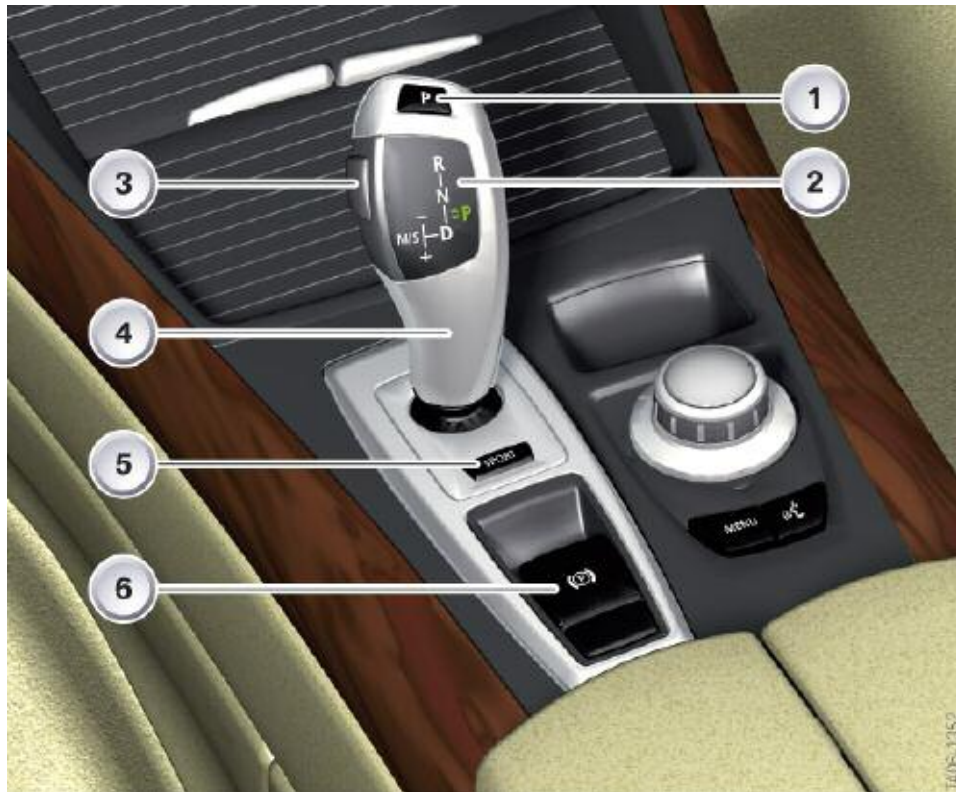

Index	Explanation	Index	Explanation
1	Parking lock button	4	Selector lever
2	Indicator	5	Sport button for EDC
3	Unlock button	6	Parking brake

The gear selector lever consists of the selector lever itself with indicator and the housing with the control unit.

Operation and Functions

The shift pattern is modeled on the conventional BMW automatic gearbox. It features an automatic gate and a manual gate. Only the parking lock is not engaged by pushing the selector lever forward but rather by pressing a button at the top of the selector lever.

The selector lever is monostable in both gates (manual and automatic). This means, after being moved, the selector lever always returns to its initial position. In the manual gate this is the same as automatic gearboxes with Steptronic.

In addition to the one-touch function, the selector lever can also be pushed in the automatic gate. This is comparable to the function of the direction indicator stalk in the E90.

The drive range is changed by tapping the selector lever. A direct change from "D" to "R" or vice versa can be achieved by tapping the selector lever twice or by pushing the lever.

The Unlock button is located on the left-hand side of the selector lever.

■ Haptic Locks

Electrically controlled, mechanically actuated locks ensure that the selector lever can only be pushed in the logically possible direction, e.g. only forward from "D".

These locks are also used for the shift lock function, i.e. when a drive range can be engaged only by pressing the unlock button. The selector lever is not locked if it is necessary to depress the service brake in order to engage a drive range for example.

Instead, the function is not executed and a message appears in the on-board monitor indicating: "Press brake to engage gear". The lock for moving the lever forward differs from the lock for moving the lever back. The forward lock is a double lock and can therefore prevent over-pressing the lever when a flick is possible.

In contrast to this, the backward lock can only completely prevent the movement. Whenever the selector lever can be pulled back, it can also be pulled back beyond the stop even if it no longer has a function.

The following graphics illustrate the operating options. The arrows indicate:

- Yellow arrow - Movement possible only with unlock button pressed.
- Grey arrow - Movement not possible.
- Green arrow - Movement possible.

Operating options of the gear selector lever

Shift from "P"



A drive range or neutral "N" can be engaged from "P" only with the unlock button pressed and the service brake depressed.

- Fully pressing forward selects the drive stage "R".
- Pressing forward selects the neutral position "N".
- Pressing back selects the drive range "D".
- Fully pressing back is possible but has no function as "D" has already been engaged at this time.

The selector lever is not locked if the brake pedal is not locked - movement is possible but the EGS will not engage the drive range or "N".

Operating options of the gear selector lever

Shift from "N"



- Pressing forward selects the drive stage "R". This is possible only with the unlock button pressed.
- Pressing back selects the drive range "D".
- Fully pressing back is possible but has no function as "D" has already been engaged at this time.

Engaging a drive range from "N" at a speed < 5 km/h is possible only with the service brake pressed. The selector lever, however, is not locked.

At a speed > 5 km/h, the drive range can be engaged in the corresponding direction without having to press the brake pedal.

Operating options of the gear selector lever

Shift from "D"



- Fully pressing forward selects the drive stage "R". This is possible only with the unlock button pressed. The EGS engages drive range "R" only when the service brake is pressed and the speed is < 5 km/h. Otherwise "N" is selected. The selector lever is therefore not locked.
- Pressing forward selects the neutral position "N".
- Pressing back is prevented by a lock.
- Pressing to the left selects the "M/S" gate.

Operating options of the gear selector lever

Shift from "R"



- Pressing forward is prevented by a lock.
- Pressing back selects the neutral position "N".
- Pressing fully back selects the drive range "D".

The EGS engages drive range "D" only when the service brake is pressed. Otherwise "N" is selected. The selector lever is therefore not locked.

Manual Gate, Sport Program (M/S)

As before, the sport program is engaged by shifting the selector lever to the left. The selector lever locks in this position. The sport program can only be engaged from "D".

Parking Lock "P"

The parking lock "P" is engaged by pressing the button at the top of the selector lever when the vehicle speed is < 2 km/h.

The gearbox also automatically selects "P" as soon as the engine is turned off and "N" is not engaged.

Automatic Downshift from "M/S"

The automatic downshift function returns the selector lever from the "M/S" gate to the automatic gate.

This occurs, for example, when the EGS signals gearbox position "P" as is the case when the engine is shut down or the "P" button is pressed.

The selector lever remains locked in the "M/S" gate only if "S" or "M" mode is actually active while driving in forward direction or the automatic downshift is defective or receives no power supply.

5 downshift attempts are executed at intervals of approximately 5 seconds if the selector lever is blocked from the outside, e.g. by an object.

If the downshift cannot be executed, the check control message: "Move selector lever back into automatic gate" appears after two attempts. A fault code memory entry is generated.

Interface to EGS

With the aim of increasing availability, the gear selector lever position is sent via the PT-CAN and LIN-bus. This means, a signal is still sent to the EGS should the PT-CAN fail. This is not necessary for safety reasons.

Safety is guaranteed by neutrally complementary signals or alive counters. The gear selector switch (GWS) is woken by a high-level on the PT-CAN wake-up line. The GWS itself has no active wake-up capabilities.

■ Definition of Messages

Interface	From	To	Message
PT-CAN	GWS	EGS	Gear selector lever operation
PT-CAN	EGS	GWS	Show gearbox data
LIN-bus	GWS	EGS	Gear selector lever operation
LIN-bus	EGS	GWS	Show gearbox data

Communication

The data blocks are sent both event controlled as well as cyclically on the PT-CAN. They are sent only cyclically on the LIN-bus. Complementary signals are sent for the purpose of securing the transmission link.

These signals are compared with the actual signals in the respective receive control unit. Alive counters serve the purpose of detecting defects in the transmit control unit. The alive counter in the respective receive control unit is monitored to establish whether it remains at a constant value.

A plausibility check between the signals of the PT-CAN transmission and of the LIN-bus does not take place in the receive control unit.

■ Safe Status for Sending

If a GWS-internal plausibility check determines that the position of the selector lever can be transmitted incorrectly, the system assumes the safe status for sending the message "Operation of gear selector lever".

Consequently, all signals of this message are sent invalid on the PT-CAN and the LIN-bus. If it is not possible to ensure that the signals can be sent invalid, the sending of these messages is completely deactivated.

Indicator in the Gear Selector Lever

The task of the indicator in the gear selector lever (GWS) is to reliably indicate the drive range currently engaged. The indicator consists of the locator light that represents the shift pattern and the function lighting. This comprises the various position LEDs that indicate the drive range currently engaged.

The function lights in the gear selector lever are controlled by the "Indicate gearbox data" message sent from the EGS. It is necessary to monitor the function lighting. For this purpose, the indication is read back and compared with the required indication.

The indicator is active as soon as bus communication is active on the PT-CAN or the LIN-bus.

Flashing of a Position LED

A position LED flashing draws the driver's attention to incorrect operation. The locator lighting remains constant and does not flash. The flashing action is triggered by an EGS signal. The frequency is 0.5 Hz.

Indicator Flashing Through Diagnosis

The entire function lighting can be made to flash at a frequency of 1 Hz for approximately 10 seconds by means of a diagnosis job for testing the indicator.

Secure Indicator Status

The indicator is a safety-relevant function so that incorrect indication must be prevented. The system assumes the secure indicator status if the possibility of an incorrect indication cannot be ruled out.

The function lighting is switched off for this purpose. The locator lighting remains switched on.

Transfer to the secure status can be triggered by two events:

- Defective communication on the bus or
- An internal defect in the gear selector lever

The main transmission path to the EGS is the PT-CAN. If the "Display gearbox data" message is not received correctly on the PT-CAN, the gear selector lever will change over to the LIN-bus. If, after changing over to the LIN-bus, a fault is also detected on this communication path, the system will assume the secure status. The plausibility check of the LIN-bus is constantly executed in the background. If it is necessary to change over to the LIN-bus in the event of a defect, it is possible to switch directly to the secure indicator state if the system detects beforehand that there are problems with the communication on the LIN-bus.

A fault code entry is generated in response to changing over to the secure status due to communication problems. This fault situation is irreversible. If the "Display gearbox data" message is received correctly again, the indicator will be activated normally once again after 2 seconds.

The gear selector lever immediately changes over to the secure indicator status if the diagnostic function in the gear selector lever detects an implausibility regarding the indicator.

In this case, a corresponding fault code entry is generated. This fault case is not reversible until the next time the gear selector lever assumes sleep mode.

Park and Unlock Button

Evaluating the P-button

The P-button sends the driver's choice to apply the parking lock to the EGS.

- The P-button is read by means of two contacts in inverse logic.
- The two contacts are evaluated in separate logic and represented by the two signals P1 and P2 independent of each other.
- Before being sent, the P2 signal is inverted in the gear selector lever.
- The two contacts in the gear selector lever are compared for diagnostic purposes. A fault code entry is stored if different contacts are applied for longer than 2 seconds.
- An internal diagnostic function in the gear selector lever detects a defective contact and enters a corresponding fault code in the fault code memory.
- The button sticking is detected when at least one contact is applied for longer than 2 minutes.
- The P1 and P2 signals are sent independent of each other on the PT-CAN and redundantly on the LIN-bus to the EGS.
- Due to the confirmation tolerances, one signal can be sent as confirmed before the other.

If the required conditions are met (speed, etc.), the EGS will engage the parking lock when at least one signal (P1 and/or P2) was sent as confirmed.

Evaluating the Unlock Button

The lock to shift to "R" or out of "P" is released by pressing the unlock button.

- The unlock button is read by means of two contacts in inverse logic.
- The two contacts in the gear selector lever are compared for diagnostic purposes. A fault code entry is stored if different contacts are applied for longer than 2 seconds.
- An internal diagnostic function in the gear selector lever detects a defective contact and enters a corresponding fault code in the fault code memory.
- Before being sent, the P2 signal is inverted in the gear selector lever.
- The button sticking is detected when at least one contact is applied for longer than 2 minutes.
- Both signals are sent on the PT-CAN and redundantly on the LIN-bus to the EGS as soon as a contact is detected as confirmed.

Components

Sensors

The selector lever position is detected without contact with the aid of seven Hall sensors for detecting the selector lever position in the longitudinal direction of the vehicle as well as four Hall sensors for detecting the selector lever position in the transverse direction of the vehicle.

In the event of one individual sensor failing, the software in the gear selector lever is still capable of calculating the correct position of the selector lever.

Actuators

Three actuators are used. A motor with subsequently connected gear mechanism is used for shifting out of the "M/S" gate and for the lock (inhibit) to "M/S".

A bi-directional spring-centered double magnet is used for the inhibit in "R" direction. A single magnet with spring reset is used for the inhibit in "D" direction. The actuators do not inhibit the shift to "R" and "D" in the case of fault or if no power is applied.

Emergency Release of Parking Lock

In the case of emergency (e.g. failure of the system voltage), the parking lock can be released by correspondingly operating the emergency release.

To access the emergency release, the rubber inlay in the front cup holder is first removed and then the cover released by turning in counter-clockwise direction. The emergency release is now accessible.

The vehicle tool kit includes a handle for the emergency release. This handle is inserted in the emergency release. The parking lock is released by turning in clockwise direction.

The emergency release is locked by pressing down on the handle. The handle for the emergency release of the parking lock is also used for the emergency release of the electro-mechanical parking brake.



In the event of the system voltage failing, first release the electro-mechanical parking brake (EMF) as the handle remains in the emergency release.

Note: Do not remove the handle from the emergency release while the vehicle is being towed as this will reengage the parking lock.

Releasing the parking lock with the emergency release generates a fault code entry in the EGS: "Parking lock release error"

GA6HP19/26TU Gearbox

The gearbox has been optimized in terms of gearshift comfort, dynamics and reducing fuel consumption.

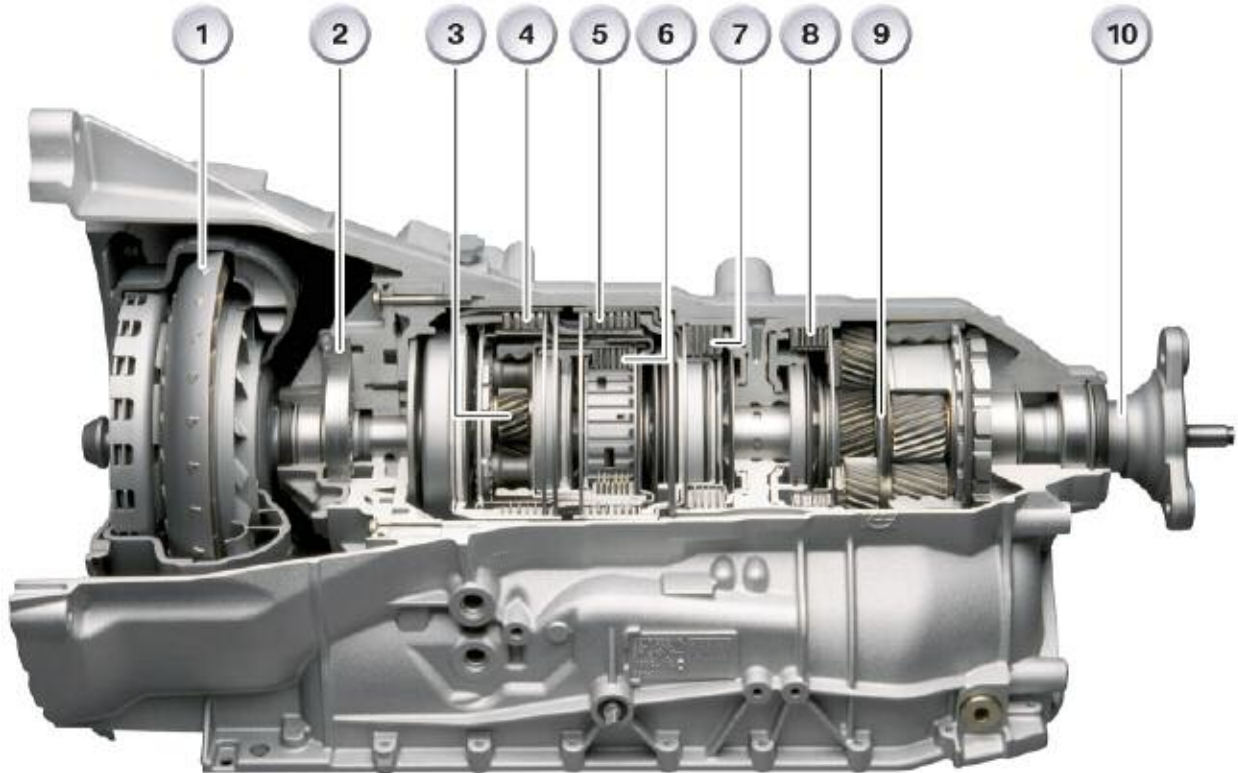

Index	Explanation	Index	Explanation
1	Torque converter with TTD and lock-up clutch	6	Drive clutch E
2	Oil pump	7	Brake clutch C
3	Single gear train	8	Brake clutch D
4	Drive clutch A	9	Double gear train
5	Drive clutch B	10	Output flange

Casing and Intermediate Plate

The casing and the intermediate plate of the GA6HPTU gearbox have been adapted to the new hydraulic unit and the resulting channel arrangement.

The GA6HPTU gearbox is a reengineered version of the 6-speed automatic gearbox that was introduced in the E65 and since then used in all model series.

The modifications are specifically targeted at achieving higher dynamics, lower fuel consumption and reduced pollutant emissions.

Torque Converter

A new torque converter is used in the GA6HPTU gearbox. This torque converter contains an effective torsion damper system known as the turbine-torsion damper (TTD).

This is a classic torsion damper, in which the primary side (engine side) is fixed to the turbine wheel of the torque converter. This arrangement brings about an increase in the flywheel mass on the primary side thus distinctly improving the damping properties.

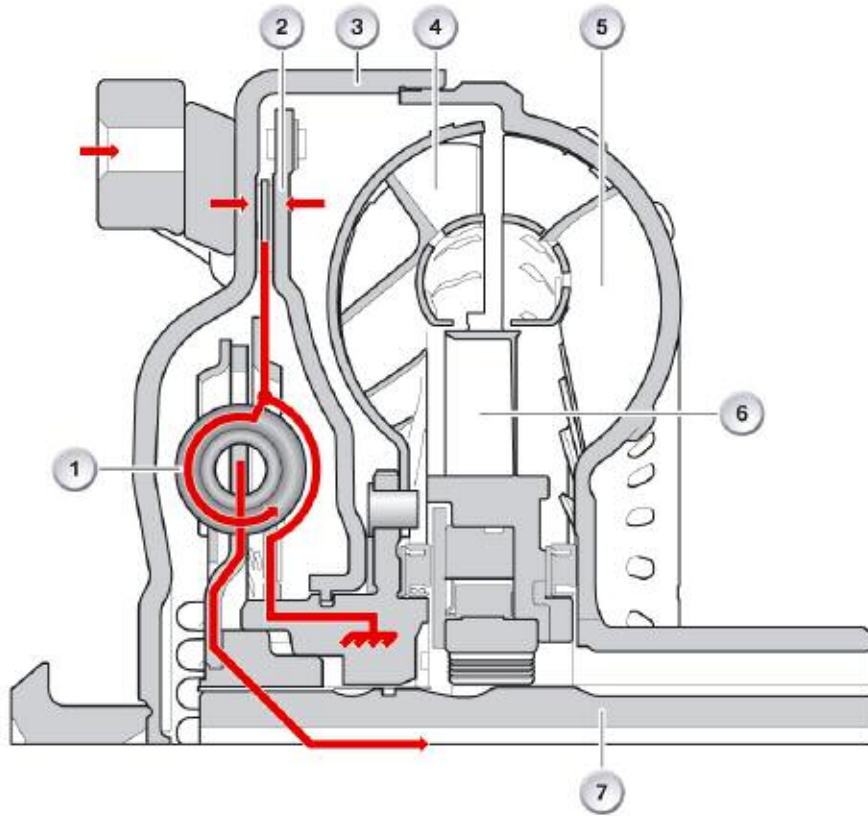

Index	Explanation	Index	Explanation
1	Annular spring plate	5	Impeller
2	Converter lockup clutch piston	6	Stator
3	Converter housing	7	Gearbox input shaft
4	Turbine wheel		

With the converter lockup clutch disengaged, i.e. in converter mode, the power flow from the turbine wheel does not take place in the usual manner to the transmission input shaft. The turbine wheel transmits the power to the primary side of the torsion damper. The secondary side of the turbine-torsion damper is connected to the input shaft of the gearbox.

Since the converter transmits no vibrations, the torsion damper need not perform any damping work. In this case it functions virtually as a rigid transmission element.

When the converter lockup clutch is engaged, the power is transmitted directly from the clutch to the primary side of the turbine torsion damper. Due to the rigid connection to the turbine wheel of the torque converter, the flywheel mass is increased on the primary side.

The power is transmitted via the turbine-torsion damper to the input shaft of the gearbox. Torsional vibration is filtered out very effectively.

With this system, it is possible to engage (close) the converter lockup clutch much earlier without having to take any deterioration in comfort into account. This arrangement directly connects the gearbox to the engine, resulting in a boost in dynamics as well as a reduction in fuel consumption and exhaust emissions.

Clutches

The clutch E has been reworked. The clutch E is a drive clutch that connects the ring gear of the single planetary gear train with the long planet gear of the double planetary gear train.

It is closed in fourth, fifth and sixth gear. The lining of clutch E is made from a new material that offers greater stability in terms of vibration and squeaking.

Mechatronics Module

Converter lockup clutch connection stages

The ability of the new torque converter to dampen torsional vibration with the turbine torsion damper is used to keep the converter lockup clutch closed as often as possible. This means the gearbox is connected directly to the engine.

A general statement as to under what conditions the converter lockup clutch is disengaged (open) or engaged (closed) can still not be made as this depends on very many factors.

- Load choice signal (accelerator pedal position)
- Engine load status
- Vehicle speed
- Transmission fluid temperature
- Selected gearshift program

The following graphic, however, shows the strategy as to when the converter lockup clutch should be disengaged or engaged, i.e. when converter lockup clutch control is required.

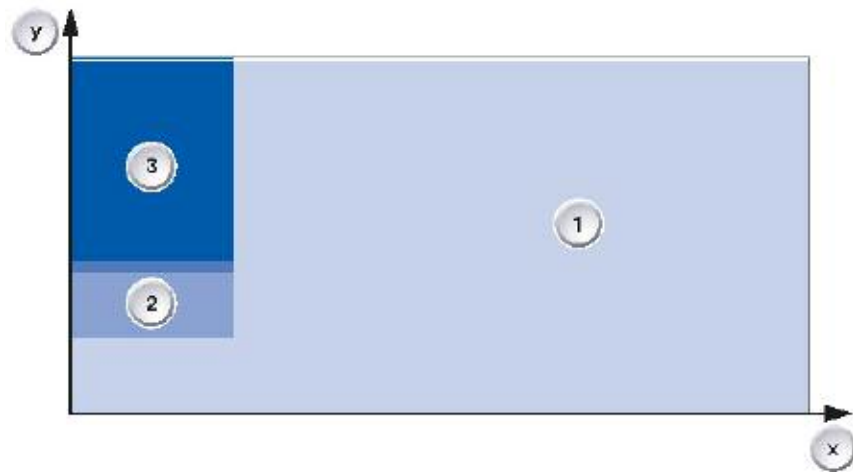

Index	Explanation	Index	Explanation
X	Vehicle speed	2	Low slip
Y	Accelerator pedal position	3	High slip
1	Converter lockup clutch engaged		

As the previous graphic illustrates, the converter lockup clutch is engaged (closed) (1) over large ranges during vehicle operation. The clutch is only controlled in the low speed ranges (2 + 3). Greater slip (3) is permitted in response to high load requirements in order to avoid the generation of noise and vibration.

When the load requirement is low, the slip at the converter lockup clutch is also kept low to enable a more direct connection. For reasons of simplicity, the previous graphic does not illustrate when the converter lockup clutch is open, e.g. when the vehicle is stationary or when starting off.

The driver experiences the direct link from the engine to the gearbox as a distinct boost in dynamics. Output speed follows the engine speed when the foot is pressed down and lifted off the accelerator. There is no familiar jump in engine speed as illustrated in the following graphic.

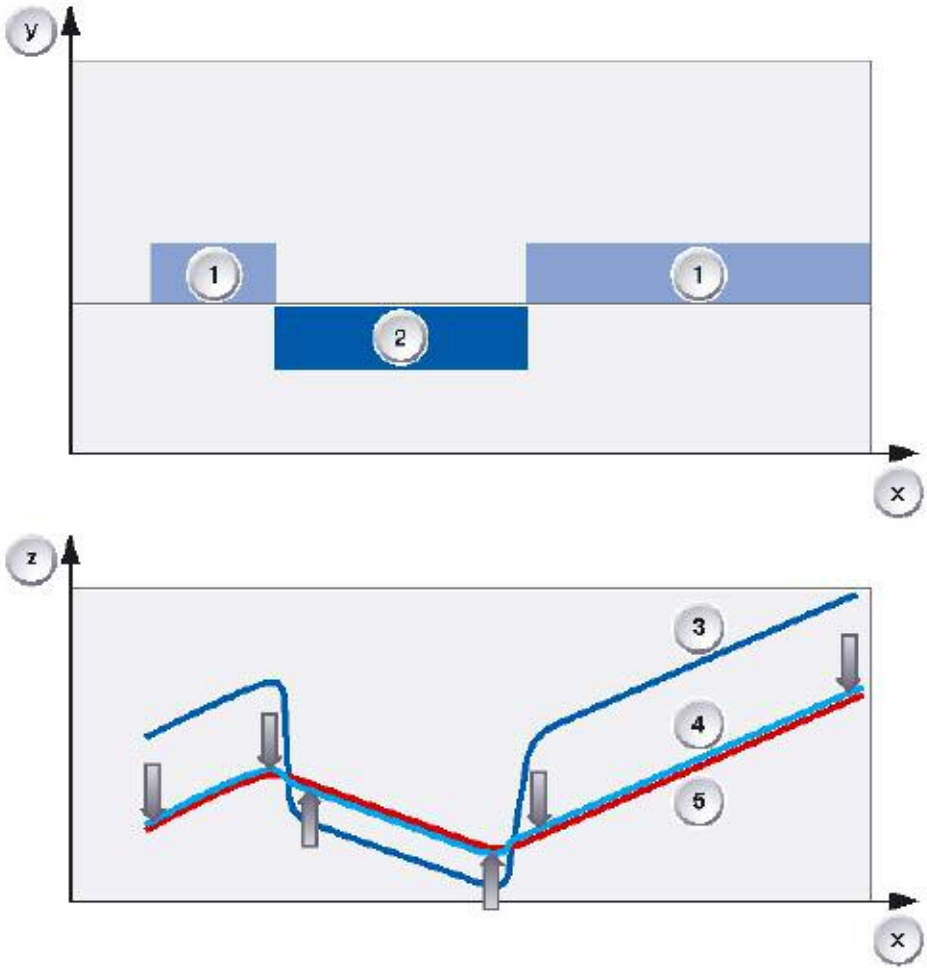

Index	Explanation	Index	Explanation
X	Time	2	Slip
Y	Accelerator pedal position	3	Previously: engine speed with TCC slip
Z	Engine speed	4	New: engine speed with direct connection
1	Load	5	Output speed

Target gear allocation dependent on accelerator pedal gradient

Target gear allocation dependent on the accelerator pedal gradient replaces the previous target gear allocation system dependent on the accelerator pedal for the purpose of shifting down while accelerating.

In the case of accelerator-dependent target gear allocation, based on the respective downshift characteristic curves, the EGS determines whether a downshift is necessary while accelerating.

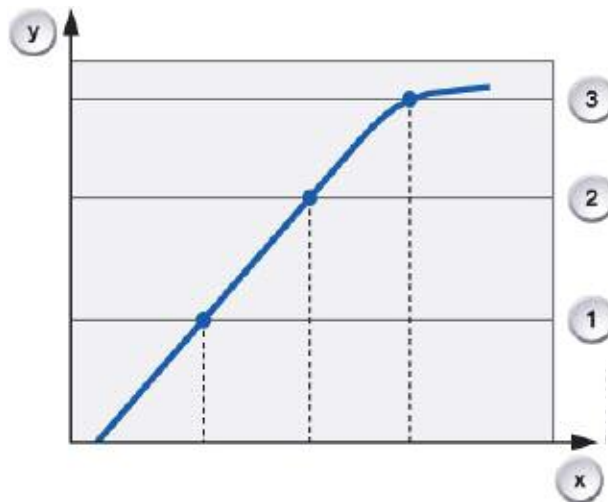

Index	Explanation
x	Time
y	Accelerator pedal position
1	1st downshift characteristic
2	2nd downshift characteristic
3	3rd downshift characteristic

The gearbox shifts down by one gear if the accelerator pedal is pressed and the first downshift characteristic is reached within a certain time. If the accelerator pedal is pressed further, the gearbox shifts down again to the second downshift characteristic and again to response to the third downshift characteristic.

In the case of accelerator pedal gradient dependent target gear allocation, the EGS determines the target gear already at the first downshift characteristic.

The accelerator pedal gradient is used for this purpose. This is the angle the movement of the accelerator pedal currently described or expressed more simply, the speed at which the accelerator pedal is depressed.

The target gear which is now determined in connection with the first downshift characteristic is engaged by a multiple downshift function. This serves as a boost to overall dynamics as the corresponding gear is engaged earlier and the interruption in tractive power is minimized.

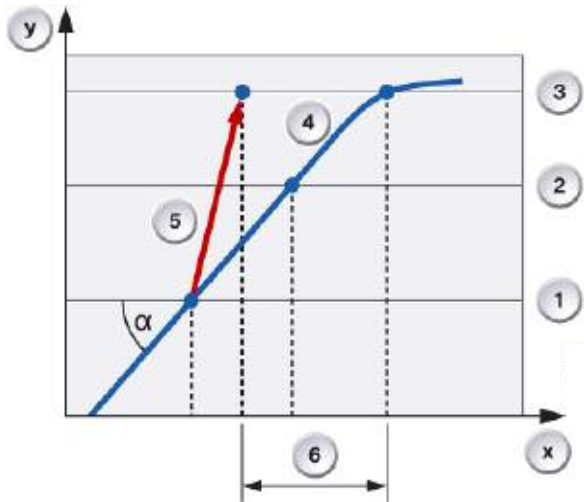

Index	Explanation
x	Time
y	Accelerator pedal position
a	Accelerator pedal gradient
1	1st downshift characteristic
2	2nd downshift characteristic
3	3rd downshift characteristic
4	Accelerator pedal movement
5	Multiple downshift
6	Dynamics boost

Shift Speed Characteristics

The transmission control now has three different shift speed levels known as quickshift 1, 2 and 3. The higher the level, the faster the gearshift. The respective shift speed level is selected as a function of the selected drive program ("D", "S" or "M") and the accelerator pedal gradient, i.e. as a function of the speed at which the pedal is depressed. The table below shows an overview of the shift speed levels:

		D	S	M
Quickshift 0	Comfortable	●	-	-
Quickshift 1	Comfortable and fast	●	●	●
Quickshift 2	Sport	-		●

Torque Intervention

When shifting gear at low load or when coasting, the EGS sends a so-called torque pulse to the engine management in order to achieve a torque intervention. This is negative when upshifting so that the engine speed is reduced. When downshifting while coasting, the torque intervention is positive in order to boost the engine speed. This torque intervention facilitates smooth gearshifts without the torque converter having to intervene in this task.

■ LIN-Bus Module

The EGS now contains a LIN-bus module for communication with the gear selector lever (GWS).

Electronic-hydraulic Control

The electronic-hydraulic control installed in the GA6HP19/26TU has been optimized in the following areas with regard to faster gearshift operations and higher efficiency.

- Torque converter control
- Cooling oil flow
- System pressure in "R"
- Clutch valves
- Electronic pressure control valves

The electronic-hydraulic control now has only two solenoid valves but seven electronic pressure control valves.

Torque Converter Control

The torque converter control including the converter lockup clutch has undergone distinct improvements with regard to the control capabilities under all conditions.

It is equipped with a new pressure regulator. Raised converter pressure (increased from approximately 0.5 bar to 1 bar at the low end) ensures faster control of the converter lockup clutch particularly at low temperatures.

The oil feed comes from the primary connection of the main pressure control valve, thus improving control at low speeds. The converter lockup clutch is now engaged with a backpressure in order to proportionate more effectively.

■ Variable Cooling Oil Flow

The flow of cooling oil is variable in order to reduce power losses. No cooling is required for the clutch faces when the converter lockup clutch is engaged (closed). The flow of cooling oil can be reduced in this state thus also reducing the pump power. The flow of cooling oil is controlled by the main pressure and can vary between 10 l/min and 15 l/min.

System Pressure in Reverse Gear

The system pressure that is applied in reverse gear has been increased from 15 bar to 16 bar. This change caters for the higher torque and the higher possible total weight. It ensures that clutch slip is prevented even in extreme situations (e.g. uphill gradient with trailer).

Clutch Valves

The clutch valves now exhibit a smaller control space. This facilitates a more spontaneous response as the time required until the clutch valve reacts to the control pressure applied by the EDS is shorter. This results in distinctly shorter gearshift times.

Solenoid Valves (MV)

Two solenoid valves are mounted on the hydraulic selector unit. These valves are designed as 3/2-way valves, i.e. valves with three connections and two switch positions.

The solenoid valves are controlled by the electronic transmission control (EGS) and assume the "opened" or "closed" positions making it possible to switch over the hydraulic valves.

The two solenoid valves are used for the electronically switched parking lock. One solenoid valve controls the valve for the parking lock and the other solenoid valve locks the cylinder for the parking lock.

Electronic Pressure Control Valves (EDS)

The electronic pressure control valves convert electrical current into a proportional hydraulic pressure. They are driven by the EGS and operate the hydraulic valves belonging to the shift elements.

The solenoid valve that the EDS (4) in the predecessor model assigned to the clutches (D and E) depending on the gear to be shifted is no longer required. Instead another electronic pressure control valve is used so that each clutch is now controlled by its own electronic pressure control valve.

The pressure control valve 7 maintains a constant system pressure during the gearshift operations, thus making shorter shift times possible.

The tasks of the electronic pressure control valves are listed in the following:

EDS Valve	Influence on shift element
1	Drive clutch A
2	Converter lockup clutch
3	Drive clutch B
4	Drive clutch E
5	Drive clutch C
6	Drive clutch D
7	System pressure

Three different electronic pressure control valves (EDS) are now installed which are all resistant to low temperatures. They enable stable presentation of the gearshift requirements even at low temperatures and when the transmission fluid is cold:

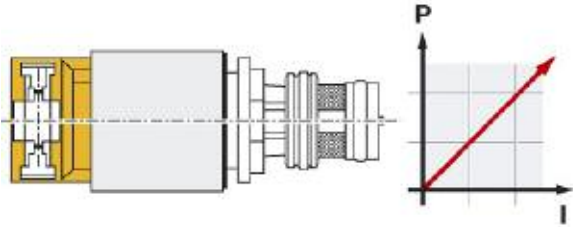
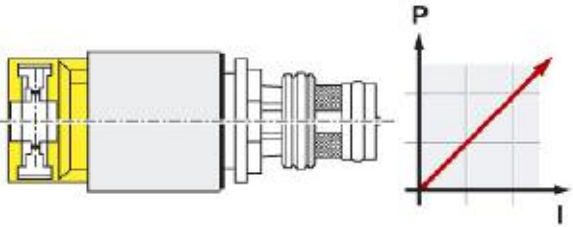
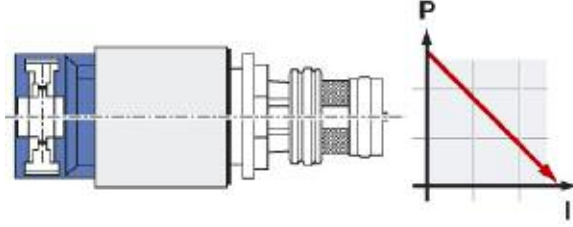
Electronic Pressure Control Valves (EDS)	
EDS with rising characteristic	
	<p>Electronic pressure control valves 1, 2: Orange cap, rising characteristic</p> <p>Technical data:</p> <ul style="list-style-type: none"> • Pressure range 0 to 4.7 bar (0 mA = 0 bar, 700 mA = 4.7 bar) • Supply voltage 12 V • Resistance 5.05 Ohm (at 20 °C)
EDS with rising characteristic	
	<p>Electronic pressure control valves 4, 5, 6: Yellow cap, rising characteristic</p> <p>Technical data:</p> <ul style="list-style-type: none"> • Pressure range 0 to 4.6 bar (0 mA = 0 bar, 700 mA = 4.6 bar) • Supply voltage 12 V • Resistance 5.05 Ohm (at 20 °C)
EDS with falling characteristic	
	<p>Electronic pressure control valves 3, 7: Blue cap, rising characteristic</p> <p>Technical data:</p> <ul style="list-style-type: none"> • Pressure range 0 to 4.6 bar (700 mA = 0 bar, 0 mA = 4.6 bar) • Supply voltage 12 V • Resistance 5.05 Ohm (at 20 °C)

Gear Selector Lever

Emergency Release of Parking Lock

In the event of the system voltage failing, first release the electro-mechanical parking brake (EMF) as the handle remains in the emergency release.

Do not remove the handle from the emergency release while the vehicle is being towed as this will reengage the parking lock.

Releasing the parking lock with the emergency release generates a fault code entry in the EGS: "Parking lock release error"

NOTES

PAGE